



- B -

MOTORI DIESEL

SERIE LDA 96

LDA	96
	97
	100
	820

LDAM 96

EDIZIONE 1973

5301.50

mod. 1354.1





CATALOGO GENERALE RICAMBI

	INDICE	TABLE	INDEX	VERZEICHNIS	INDICE
4-10	Identificazione motore	Repères moteur	Engine identification	Motormerkmale	Identificacion motor
4-21	Basamento	Carter moteur	Crankcase	Kurbelgehäuse	Bancada
4-21	Portina - Supporto	Carter - Support	Case cover - Support	Gehäuse - Lager	Tapa de carter - Soporte
4-22	Cilindro	Cylindre	Cylinder	Zylinder	Cilindro
4-22	Testa - Cappello bilanc.	Culasse - Couvercle culbut.	Cyl. head - Rocker arm cover	Zyl. kopf-Kipphebeldeck.	Culata - Tapa balancines
4-23	Convogliatore - Lamiera	Coiffe ventilateur - Tôles	Shroud - Panels	Ventilatorhaube - Bleche	Caja ventilador - Chapas
4-24	Piedi	Pattes	Engine mounts	Motorfuss	Pies
4-29	Pattino protezione	Patin protection	Guard pad	Schutz - Gleitschuh	Patin de proteccion
4-29	Ganci cofano	Crochets du capot	Hood hooks	Haubenacken	Ganchos de capo
4-31	Albero a gomito	Vilebrequin	Crankshaft	Kurbelwelle	Cigüenal
4-31	Volano - Puleggia	Volant - Poulie	Flywheel - Pulley	Schwungrad - Riemensch.	Volante - Polea
4-32	Biella - Pistone - Segmenti	Bielle - Piston - Segments	Conn. rod - Piston - Rings	Pleuelstange - Kolben-Ringe	Biela - Piston - Aros
4-33	Albero a camme - Valvole	Arbre à cames - Soupapes	Gamschaft - Valves	Nockenwelle - Ventile	Eje de levas - Valvulas
4-34	Regolatore - Leveraggio	Régulateur - Levier	Governor - Linkage	Regler - Hebelsystem	Regulador - Palancas
4-35	Protezione aste punterie	Protection tiges poussoirs	Tappet push rod tube	Stößstangenschutzrohr	Protecc. varillas impulsores
4-35	Bilancieri	Culbuteurs	Rocker levers	Kipphebel	Balancines
4-36	Suppl. combust. - Stop	Suppl. comb. - Stop	Extra fuel - Stop	Brennst.mehrmenge - Stop	Suplem. comb. - Stop
4-37	Decompressione	Décompression	Compression release	Dekompression	Descompresor
4-41	Filtro aria	Filtre à air	Air cleaner	Luftfilter	Filtro aire
4-42	Marmitta - Tubi	Pots échappem. - Tuyaux	Mufflers - Tubes	Auspufftopf - Rohre	Silenciador - Tubos
4-43	Serbatoio combustibile	Réservoir combustible	Fuel tank	Kraftstoffbehälter	Deposito combustible
4-44	Pompa alimentazione	Pompe d'alimentation	Fuel feeding pump	Kraftstoffpumpe	Bomba alimentacion
4-45	Pompa iniezione	Pompe injection	Injection pump	Einspritzpumpe	Bomba inyeccion
4-45	Portapolverizz. - Polverizz.	Porte injecteur - Injecteur	Nozzle holder - Nozzle	Düsenhalter - Einspritzdüse	Porta-inyector - Tobera
4-45	Tab. comparat. mat. iniez.	Tableau comparat. mat. inj.	Inj. system reference table	Vergleichstab. des Einspritz.	Plano com. aparato inieccion
4-47	Filtro combustibile	Filtre à combustible	Fuel filter	Brennstofffilter	Filtro combustible
4-51	Pompa olio	Pompe à huile	Lub. oil pump	Schmierölpumpe	Bomba aceite
4-54	Tappo sfiato	Bouchon reniflard	Breather cap	Entlüftungsdeckel	Placa
4-57	Filtro olio	Filtre à huile	Lub. oil filter	SchmierölfILTER	Filtro aceite
4-61	Predisp. avviam. elettrico	Predisp. démarr. électrique	Electrical starting adapter	El. Anl. Vorrichtung	Predisposicc. arranque elect.
4-61	Avv. elettr. con dinamo motore	Démarr. électr. dynastart	El. starting w. start. gen.	El. Anl. m. Lichtanlasser	Arranque el. por Dinamotor
4-61	Avv. elettr. con motorino	Démarr. électr. démarreur	Electr. starting with motor	El. Anl. m. Motor	Arranque el. por Motor
4-62	Alternatore luce	Alternateur lumière	Lighting alternator	Lichtmaschine	Alternador luz
4-64	Comando acceleratore	Commande accélérateur	Throttle control	Beschleunigungsteuerung	Mando acelerador
4-65	Comando Stop	Commande stop	Stop control	Stop - Steuerung	Mando paro
4-66	Flangiature	Brides	Flanges	Flansch	Bridas
4-67	Indicat. press. olio	Indicateur pression d'huile	Oil pressure gauge	Öldruckanzeiger	Indicador pression aceite
4-67	Spia temperatura testa	Témoin temperature culasse	Cyl. head temperature gauge	Kopftemp.-Kontr. leuchte	Espia temperatura culata
4-67	Quadretti di manovra	Tableaux distribution	Panel boards	Schaltkasten	Quadros distribucion
4-68	Avv.to a funicella	Démarrage par cordelette	Rope starting	Seilanlasser	Arranque de cuerda
4-68	Avv.to a manovella	Lancement par manivelle	Hand-crank starting	Handkurbelanlasser	Arranque de manivela
4-71	Motore versione marina	Moteur version marine	Marine version engine	Marine Ausführung	Motor marino
4-72	Frizione	Embrayage	Clutch	Reibungskupplung	Embrague
4-72	Frizione riduttore	Embrayage réducteur	Reduction gear clutch	Unters.getr. Kupplung	Embrague reductor
4-73	Giunti - Puleggia a giunto	Accoupl. - Poulie joint.	Coupling - Pulley	Kupplung - Riemenscheibe	Acoplamiento - Polea
4-74	Riduttore	Réducteur	Reduction gear	Untersetzungsgetriebe	Reductor
4-76	Predisp. pompa oleodinam.	Prédispos. pompe hydraul.	Hydraulic pump adapter	Hydr. - Pumpenantrieb	Predisp. bomba hidr.
4-77	Flangia	Bride	Flange	Flansch	Brida
4-81	Tabella costruttori pompe	Table fournisseur pompes	Pump supplier directory	Pumpenliefer. Verzeichnis	Indice de constr. de bombas
4-82	Equilibratore dinamico	Équilibreur dynamique	Dynamic balancer	Dyn. Massenausgleicher	Equilibrador dinamico
4-83	Blocco motore	Bloc moteur	Short block	Motorblock	Bloque motor
4-84	Serie guarnizioni	Jeu de joints	Gasket set	Dichtungssatz	Juego de juntas
4-85	Serie accessori	Jeu accessoires	Accessory set	Zubehörsatz	Série acesorios
4-85	Attrezzatura speciale	Outillages spécifiques	Special tools	Spezialwerkzeuge	Herramientas
4-100	Versioni Clienti	Adaptations Clients	O.E.M. versions	Sonderausführungen	Versiones Clientes

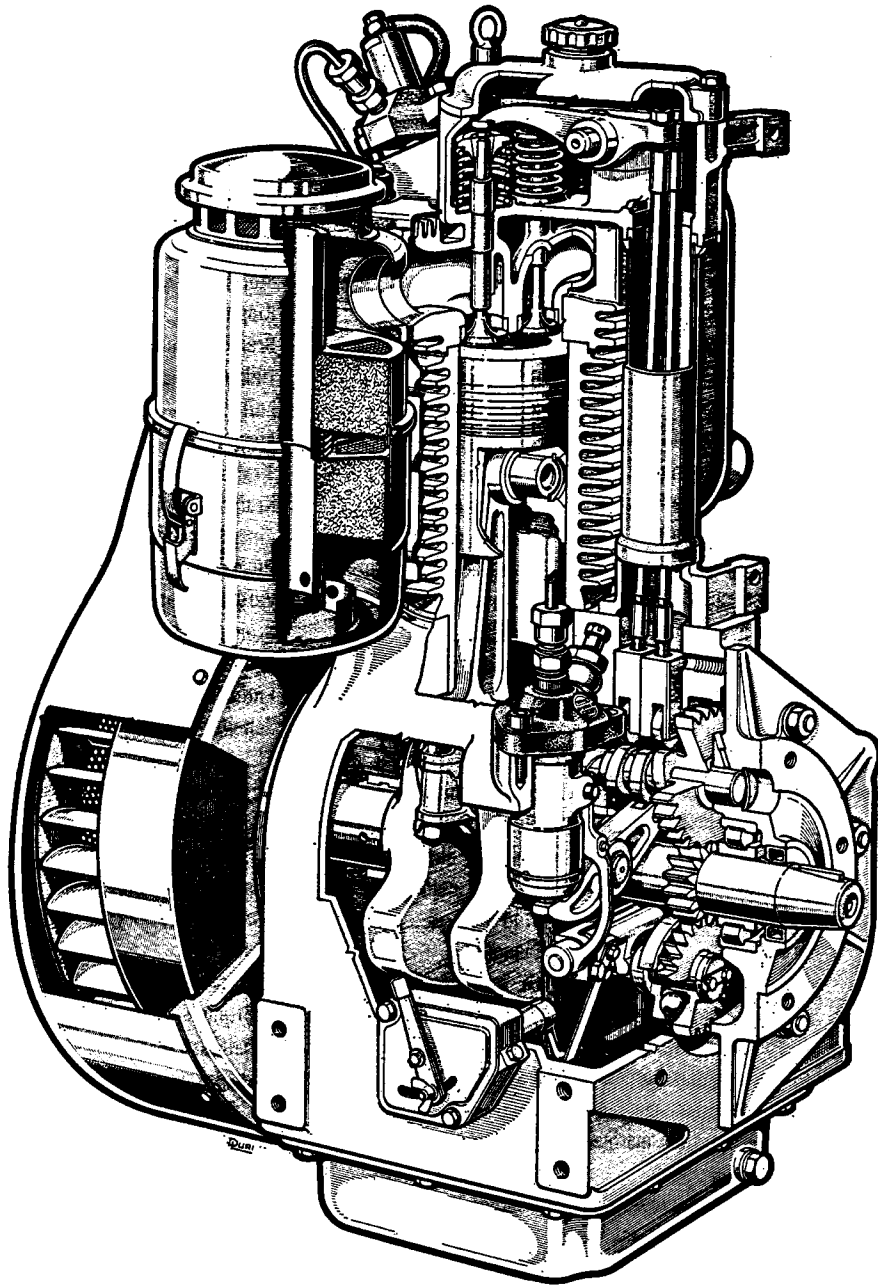

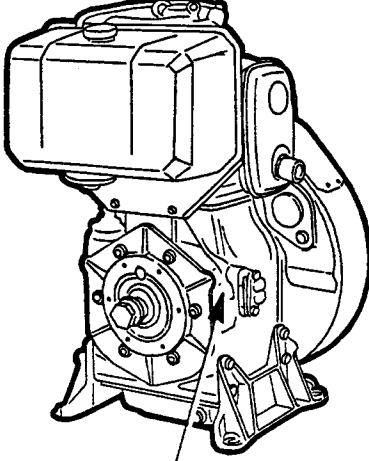
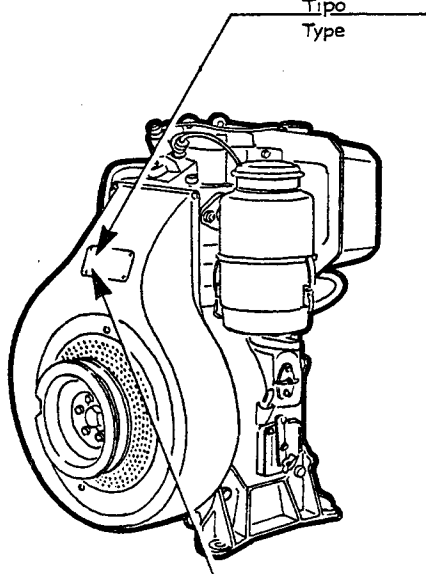

		<p style="text-align: center;">Tipo Type</p> <p style="text-align: center;">Matricola Matricule Serial No</p> <p style="text-align: center;">Caratteristiche Caracteristiques Characteristics</p> <p style="font-size: small;">* NON FORNITO SCIOLTO NON LIVRE SEPAREMENT NOT SUPPLIED SEPARATELY</p>
<p>COMPLESSIVO - GROUPE - ASSEMBLY</p>		<p>TAVOLA TABLE 4 10 0</p> <p>FOGLIO FEUILLE</p> <p>DATA DATE 2-73</p>
<p>MOTORE O VERSIONE MOTEUR OU ADAPTATION ENGINE OR VERSION</p>		<p style="text-align: center;">IDENTIFICAZIONE MOTORE REPERES MOTEUR ENGINE IDENTIFICATION</p>

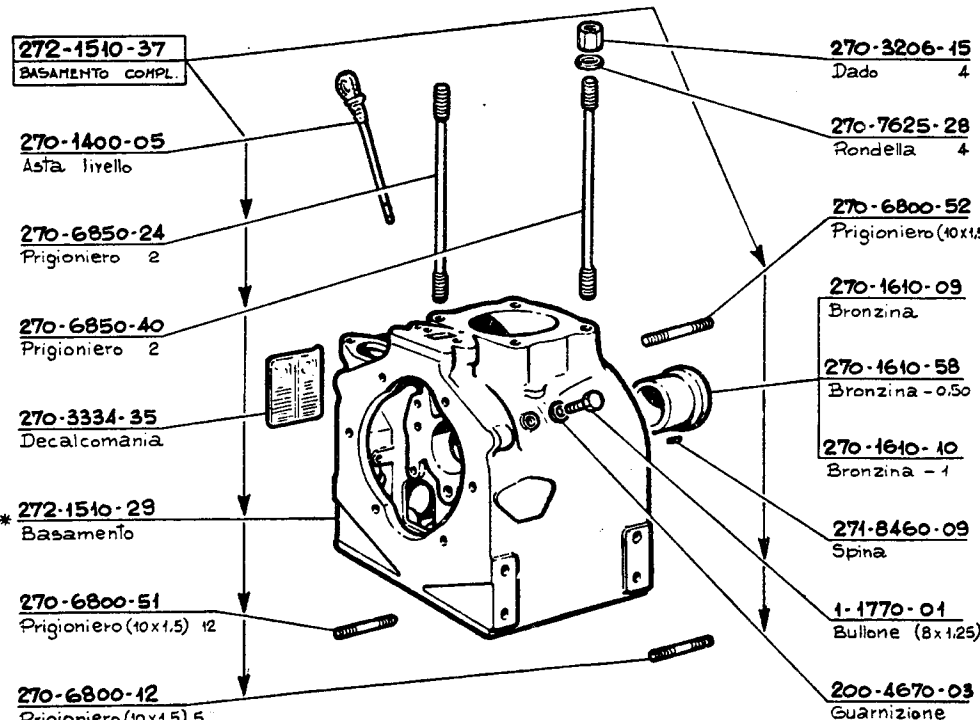
	<p style="font-size: small;">NOTE - REMARQUES - REMARKS</p> <p>-Fino a } LDA 96 N° 497643 -Jusqu'au } LDAM96 -Below } LDA 97 N° 505953</p> <p>272-1510-37 BASAMENTO COMPL.</p> <p>270-1400-05 Asta livello</p> <p>270-6850-24 Prigioniero 2</p> <p>270-6850-40 Prigioniero 2</p> <p>270-3334-35 Decalcomania</p> <p>* 272-1510-29 Basamento</p> <p>270-6800-51 Prigioniero (10x1.5) 12</p> <p>270-6800-12 Prigioniero (10x1.5) 5</p> <p>270-3206-15 Dado 4</p> <p>270-7625-28 Rondella 4</p> <p>270-6800-52 Prigioniero (10x1.5)</p> <p>270-1610-09 Bronzina</p> <p>270-1610-58 Bronzina - 0.50</p> <p>270-1610-10 Bronzina - 1</p> <p>271-8460-09 Spina</p> <p>1-1770-01 Bullone (8x1.25)</p> <p>200-4670-03 Guarnizione</p> <p style="font-size: small;">* NON FORNITO SCIOLTO NON LIVRE SEPAREMENT NOT SUPPLIED SEPARATELY</p>	<p style="font-size: small;">NOTE - REMARQUES - REMARKS</p> <p>TAVOLA TABLE 4 21 1</p> <p>FOGLIO FEUILLE</p> <p>DATA DATE 2-73</p>
<p>COMPLESSIVO - GROUPE - ASSEMBLY</p>		<p>TAVOLA TABLE 4 21 1</p> <p>FOGLIO FEUILLE</p> <p>DATA DATE 2-73</p>
<p>MOTORE O VERSIONE MOTEUR OU ADAPTATION ENGINE OR VERSION</p> <p style="text-align: center;">LDA 96-97-LDAM 96</p>		<p style="text-align: center;">BASAMENTO STANDARD CARTER MOTEUR STANDARD STANDARD CRANKCASE</p>



270-3206-15
Dado 4

270-7625-28
Rondella 4

272-1511-63
BASAMENTO COMPL. LDA 96-97-LDAM 96.

279-1511-75
BASAMENTO COMPL. LDA 100.

291-1511-96
BASAMENTO COMPL. LDA 820.

270-1400-05
Asta livello LDA 96-97-100.
LDAM 96

291-1400-45
Asta livello LDA 820.

270-6850-24
Prigioniero 2

270-6850-40
Prigioniero 2

270-3334-35
Decalcomania

* **272-1511-47**
Basamento LDA 96-97-LDAM 96.

* **279-1511-46**
Basamento LDA 100.

* **291-1511-57**
Basamento LDA 820.

270-6800-53
Prigioniero (10x1,5) 6

443-6800-10 (C)
Prigioniero (10x1,5) 5

270-6800-55
Prigioniero (10x1,5)

279-6800-59
Prigioniero

270-1610-09
Bronzina

270-1610-58
Bronzina - 0,50

270-1610-10
Bronzina - 1

270-8460-54
Spina

236-6800-18
Prigioniero (10x1,5) 2

270-3901-41
FLANGIA COMPL.

200-4670-03
Guarnizione

1-1770-01
Bullone (8x1,25)

264-8965-03
Tappo (12x1,5)

4670-15
Guarnizione

270-3901-27*
Flangia

47-1770-07
Bullone (8x1,25) 2

250-7555-07
Rondella 2

270-4730-21*
Guarnizione

NOTE - REMARQUES - REMARKS

-Da LDA 96
-A partir de LDA 96 № 497644
-Starting from LDA 97 № 505954

(a) -Solo LDA 96-97-LDAM 96 e LDA 100 non predis. avviam. elettr. e LDA 820.
-Seulement LDA 96-97-LDAM 96 et LDA 100 non predis. dém. électr. et LDA 820.
-Only LDA 96-97-LDAM 96 and LDA 100 not suitable for el. start.

(b) -Solo LDA 100 predis. avviam. elettr. e LDA 820.
-Seulement LDA 100 predis. dém. électr. et LDA 820.
-Only LDA 100 suitable for el. start, and LDA 820.

(c) -LDA 96-97-LDAM 96 e LDA 100 non predis. avviam. elettr. № 5 pezzi LDA 100 predis. e LDA 820 № 3 pezzi LDA 96-97-LDAM 96 et LDA 100 non predis. dém. électr. № 5 pièces LDA 100 predis. et LDA 820 № 3 pièces LDA 96-97-LDAM 96 and LDA 100 not suitable for el. start. № 5 pieces LDA 100 suitable and LDA 820 № 3 pieces

(d) -Solo LDA 100 predis. avviam. elettr. e LDA 820.
-Seulement LDA 100 predis. dém. électr. et LDA 820.
-Only LDA 100 suitable el. start, and LDA 820.

* NON FORNITO SCOLTO
NON LIVRE SEPARATEMENT
NOT SUPPLIED SEPARATELY

COMPLESSIVO - GROUPE - ASSEMBLY	TAVOLA TABLE		4	21	2
MOTORE O VERSIONE MOTEUR OU ADAPTATION ENGINE OR VERSION	BASAMENTO STANDARD CARTER MOTEUR STANDARD STANDARD CRANKCASE		FOGLIO FEUILLE PAGE	1	2
			DATA DATE	2-73	

270-3206-15
Dado 4

270-7625-28
Rondella 4

272-1511-63
BASAMENTO COMPL. LDA 96-97-LDAM 96.

279-1511-75
BASAMENTO COMPL. LDA 100.

291-1511-96
BASAMENTO COMPL. LDA 820.

270-1400-05
Asta livello LDA 96-97-100.
LDAM 96

291-1400-45
Asta livello LDA 820.

270-6850-24
Prigioniero 2

270-6850-40
Prigioniero 2

270-3334-35
Decalcomania

* **272-1511-47**
Basamento LDA 96-97-LDAM 96.

* **279-1511-46**
Basamento LDA 100.

* **291-1511-57**
Basamento LDA 820.

270-6800-53
Prigioniero (10x1,5) 6

443-6800-10 (C)
Prigioniero (10x1,5) 5

270-6800-55
Prigioniero (10x1,5)

279-6800-59
Prigioniero

270-1610-09
Bronzina

270-1610-58
Bronzina - 0,50

270-1610-10
Bronzina - 1

270-8460-54
Spina

236-6800-18
Prigioniero (10x1,5) 2

270-3901-41
FLANGIA COMPL.

200-4670-03
Guarnizione

1-1770-01
Bullone (8x1,25)

264-8965-03
Tappo (12x1,5)

4670-15
Guarnizione

270-3901-27*
Flangia

47-1770-07
Bullone (8x1,25) 2

250-7555-07
Rondella 2

270-4730-21*
Guarnizione

NOTE - REMARQUES - REMARKS

-Per i motori non predis. filtro olio, oltre al basamento fornire tubo aspiraz. 270-9320-46.
-Pour moteurs non predis pour filtre huile: avec carter livrer Tuyau aspir. 270-9320-46.
-Engines not suitable for oil filter: supply crankcase and suction tube 270-9320-46.

* NON FORNITO SCOLTO
NON LIVRE SEPARATEMENT
NOT SUPPLIED SEPARATELY

COMPLESSIVO - GROUPE - ASSEMBLY	TAVOLA TABLE		4	21	2
MOTORE O VERSIONE MOTEUR OU ADAPTATION ENGINE OR VERSION	BASAMENTO STANDARD CARTER MOTEUR STANDARD STANDARD CRANKCASE		FOGLIO FEUILLE PAGE	2	2
			DATA DATE	2-73	



270-3206-15
Dado 4

270-7625-28
Rondella 4

272-1511-66
BASAMENTO COMPL LDA 96-97

279-1511-78
BASAMENTO COMPL LDA 100

291-1512-03
BASAMENTO COMPL LDA 820

270-1400-05
Asta livello LDA 96-97-100

291-1400-45
Asta livello LDA 820

270-6850-24
Prigioniero 2

270-6850-40
Prigioniero 2

270-3334-35
Decalcomania

* **272-1511-49**
Basamento LDA 96-97

* **279-1511-48**
Basamento LDA 100

* **291-1512-01**
Basamento LDA 820

3-6800-04
Prigioniero (10x1,5) 6

443-6800-10 (C)
Prigioniero (10x1,5) 5

270-6800-55
Prigioniero (10x1,5)

279-6800-59
Prigioniero

270-1610-09
Bronzina

270-1610-58
Bronzina -0,50

270-1610-10
Bronzina -1

270-8460-54
Spina

236-6800-18
Prigioniero (10x1,5) 2

270-3901-41 (b)
FLANGIA COMPL

200-4670-03
Guarnizione

1-1770-01
Bullone (8x1,25)

264-8965-03
Tappo (12x1,5)

4670-15
Guarnizione

270-3901-27 (d)
Flangia

47-1770-07
Bullone (8x1,25) 2

250-7555-07
Rondella 2

270-4730-21 (a)
Guarnizione

NOTE - REMARQUES - REMARKS

-Da LDA 96 }
-A partir de LDA 96 } N° 497644
-Starting from LDA 97 N° 505954 }
-Vedi anche Tav. } 4-82-1/2
-Voir aussi Table }
-See also Table }

(a) - Solo LDA 96-97-LDAM 96 e LDA 100 non predis. avviam. elettr. -Seulement LDA 96-97-LDAM 96 et LDA 100 non predis. dém. électr.

(b) - Solo LDA 100 predis. avviam. elettr. e LDA 820. -Seulement LDA 100 predis. dém. électr. et LDA 820.

(c) - LDA 96-97-LDAM 96 e LDA 100 non predis. avviam. elettr. N° 5 pezzi LDA 100 predis. e LDA 820 N° 3 pezzi LDA 96-97-LDAM 96 et LDA 100 non predis. dém. électr. N° 5 pièces; LDA 100 predis. et LDA 820 N° 3 pièces -LDA 96-97-LDAM 96 and LDA 100 not suitable for el. start. N° 5 pieces; LDA 100 suitable and LDA 820 N° 3 pieces

(d) - Solo LDA 100 predis. avviam. elettr. e LDA 820. -Seulement LDA 100 predis. dém. électr. et LDA 820.

-Only LDA 100 suitable el. start. and. LDA 820.

* NON FORNITO SCOLTO
NON LIVRE SEPARATEMENT
NOT SUPPLIED SEPARATELY

COMPLESSIVO · GROUPE · ASSEMBLY		TAVOLA TABLE	4	21	3
MOTORE O VERSIONE MOTEUR OU ADAPATION ENGINE OR VERSION	BASAMENTO PER EQUILIBRATORE CARTER MOTEUR POUR EQUILIBREUR CRANKCASE FOR DYNAMIC BALANCER	FOGLIO FEUILLE PAGE	1	2	
		DATA DATE	2-73		

270-3206-15
Dado 4

270-7625-28
Rondella 4

272-1511-66
BASAMENTO COMPL LDA 96-97

279-1511-78
BASAMENTO COMPL LDA 100

291-1512-03
BASAMENTO COMPL LDA 820

270-1400-05
Asta livello LDA 96-97-100

291-1400-45
Asta livello LDA 820

270-6850-24
Prigioniero 2

270-6850-40
Prigioniero 2

270-3334-35
Decalcomania

* **272-1511-49**
Basamento LDA 96-97

* **279-1511-48**
Basamento LDA 100

* **291-1512-01**
Basamento LDA 820

3-6800-04
Prigioniero (10x1,5) 6

443-6800-10 (C)
Prigioniero (10x1,5) 5

270-6800-55
Prigioniero (10x1,5)

279-6800-59
Prigioniero

270-1610-09
Bronzina

270-1610-58
Bronzina -0,50

270-1610-10
Bronzina -1

270-8460-54
Spina

236-6800-18
Prigioniero (10x1,5) 2

270-3901-41 (b)
FLANGIA COMPL

200-4670-03
Guarnizione

1-1770-01
Bullone (8x1,25)

264-8965-03
Tappo (12x1,5)

4670-15
Guarnizione

270-3901-27 (d)
Flangia

47-1770-07
Bullone (8x1,25) 2

250-7555-07
Rondella 2

270-4730-21 (a)
Guarnizione

NOTE - REMARQUES - REMARKS

Per i motori non predis. filtro olio, oltre al basamento fornire tubo aspiraz 270-9320-46.

Pour moteurs non predis. pour filtre huile: avec carter livrer tuyau aspir. 270-9320-46.

Engines not suitable for oil filter: supply crankcase and suction Tube 270-9320-46.

* NON FORNITO SCOLTO
NON LIVRE SEPARATEMENT
NOT SUPPLIED SEPARATELY

COMPLESSIVO · GROUPE · ASSEMBLY		TAVOLA TABLE	4	21	3
MOTORE O VERSIONE MOTEUR OU ADAPATION ENGINE OR VERSION	BASAMENTO PER EQUILIBRATORE CARTER MOTEUR POUR EQUILIBREUR CRANKCASE FOR DYNAMIC BALANCER	FOGLIO FEUILLE PAGE	2	2	
		DATA DATE	2-73		



270-3206-15
Dado 2

270-7625-28
Rondella 4

272-1511-69
BASAMENTO COMPL. LDA 96-97-LDAM 96

279-1511-81
BASAMENTO COMPL. LDA 100

291-1512-04
BASAMENTO COMPL. LDA 820

270-1400-05
Asta livello LDA 96-97-100 LDAM 96

291-1400-45
Asta livello LDA 820

270-6850-24
Prigioniero 2

270-6850-40
Prigioniero 2

270-3334-35
Decalcomania

* **272-1511-51**
Basamento LDA 96-97-LDAM 96

* **279-1511-50**
Basamento LDA 100

* **291-1511-58**
Basamento LDA 820

270-6800-53
Prigioniero (10x1,5) 6

443-6800-10 (C)
Prigioniero (10x1,5) 5

236-6780-12
Prigioniero (8x1,25) 2

(a) **270-6800-55**
Prigioniero (10x1,5)

(d) **279-6800-59**
Prigioniero

270-1610-09
Bronzina

270-1610-58
Bronzina -0,50

270-1610-10
Bronzina -1

270-8460-54
Spina

236-6800-18
Prigioniero (10x1,5) 2

(b) **270-3901-41**
FLANGIA COMPL.

200-4670-03
Guarnizione

1-4770-01
Bullone (8x1,25)

264-8965-03
Tappo (12x1,5)

4670-15
Guarnizione

270-3901-27*
Flangia

47-4770-07
Bullone (8x1,25) 2

250-7555-07
Rondella 2

270-4730-21*
Guarnizione

NOTE - REMARQUES - REMARKS

-Da LDA 96
-A partir de LDAM 96 N° 497644
-Starting from LDA 97 N° 505954

-Vedi anche Tav. 4-44-1
-Voir aussi Table 4-44-1
-See also Table

(a) -Solo LDA 96-97-LDAM 96 e LDA 100 non predis. avviam. elettr.
-Seulement LDA 96-97-LDAM 96 et LDA 100 non predis. dém. électr.

(b) -Solo LDA 100 predis. avviam. elettr. e LDA 820.
-Seulement LDA 100 predis. dém. électr. et LDA 820.

(c) -LDA 96-97-LDAM 96 e LDA 100 non predis. avviam. elettr. N° 5 pezzi; LDA 100 predis. e LDA 820 N° 3 pezzi; LDA 96-97-LDAM 96 et LDA 100 non predis. dém. électr. N° 5 pièces; LDA 100 predis. et LDA 820 N° 3 pièces; LDA 96-97-LDAM 96 and LDA 100 not suitable for el. start. N° 5 pieces; LDA 100 suitable and LDA 820 N° 3 pieces

(d) -Solo LDA 100 predis. avviam. elettr. e LDA 820.
-Seulement LDA 100 predis. dém. électr. et LDA 820.
-Only LDA 100 suitable el. start. and LDA 820.

* NON FORMATO SOLTTO
NON LIVRE SEPARATEMENT
NOT SUPPLIED SEPARATELY

COMPLESSIVO - GROUPE - ASSEMBLY	BASAMENTO PER POMPA ALIMENTAZIONE CARTER MOTEUR POUR POMPE D'ALIMENT. CRANKCASE FOR FUEL FEEDING PUMP		TAVOLA TABLE	4	21	4
MOTORE O VERSIONE MOTEUR OU ADAPTATION ENGINE OR VERSION			FOGLIO FEUILLE PAGE	1	2	
			DATA DATE	2-73		

270-3206-15
Dado 4

270-7625-28
Rondella 4

272-1511-69
BASAMENTO COMPL. LDA 96-97-LDAM 96

279-1511-81
BASAMENTO COMPL. LDA 100

291-1512-04
BASAMENTO COMPL. LDA 820

270-1400-05
Asta livello LDA 96-97-100 LDAM 96

291-1400-45
Asta livello LDA 820

270-6850-24
Prigioniero 2

270-6850-40
Prigioniero 2

270-3334-35
Decalcomania

* **272-1511-51**
Basamento LDA 96-97-LDAM 96

* **279-1511-50**
Basamento LDA 100

* **291-1511-58**
Basamento LDA 820

270-6800-53
Prigioniero (10x1,5) 6

443-6800-10 (C)
Prigioniero (10x1,5) 5

236-6780-12
Prigioniero (8x1,25) 2

(a) **270-6800-55**
Prigioniero (10x1,5)

(d) **279-6800-59**
Prigioniero

270-1610-09
Bronzina

270-1610-58
Bronzina -0,50

270-1610-10
Bronzina -1

270-8460-54
Spina

236-6800-18
Prigioniero (10x1,5) 2

(b) **270-3901-41**
FLANGIA COMPL.

200-4670-03
Guarnizione

1-4770-01
Bullone (8x1,25)

264-8965-03
Tappo (12x1,5)

4670-15
Guarnizione

270-3901-27*
Flangia

47-4770-07
Bullone (8x1,25) 2

250-7555-07
Rondella 2

270-4730-21*
Guarnizione

NOTE - REMARQUES - REMARKS

-Per i motori non predis. filtro olio; oltre al basamento fornire tubo aspiraz. 270-9320-46.
-Pour moteurs non predis. pour filtre huile; avec carter livrer tuyau aspir. 270-9320-46.

-Engines not suitable for oil filter: supply crankcase and suction tube 270-9320-46.

* NON FORMATO SOLTTO
NON LIVRE SEPARATEMENT
NOT SUPPLIED SEPARATELY

COMPLESSIVO - GROUPE - ASSEMBLY	BASAMENTO PER POMPA ALIMENTAZIONE CARTER MOTEUR POUR POMPE D'ALIMENT. CRANKCASE FOR FUEL FEEDING PUMP		TAVOLA TABLE	4	21	4
MOTORE O VERSIONE MOTEUR OU ADAPTATION ENGINE OR VERSION			FOGLIO FEUILLE PAGE	2	2	
			DATA DATE	2-73		



270-3206-15
Dado 4

270-7625-28
Rondella 4

272-1511-72
BASAMENTO COMPL. LDA 96-97.

279-1511-84
BASAMENTO COMPL. LDA 100.

291-1512-05
BASAMENTO COMPL. LDA 820.

270-4400-05
Asta livello LDA 96-97-100.

291-4400-45
Asta livello LDA 820.

270-6850-24
Prigioniero 2

270-6850-40
Prigioniero 2

270-3334-35
Decalcomania

* **272-1511-53**
Basamento LDA 96-97.

* **279-1511-52**
Basamento LDA 100.

* **291-1512-02**
Basamento LDA 820.

270-6800-53
Prigioniero (10x1,5) 6

443-6800-10
Prigioniero (10x1,5) 5

236-6780-12
Prigioniero (8x1,25) 2

270-6800-55
Prigioniero (10x1,5)

279-6800-59
Prigioniero

270-1610-09
Bronzina

270-1610-58
Bronzina - 0,50

270-1610-10
Bronzina - 1

270-8460-54
Spina

236-6800-18
Prigioniero (10x1,5) 2

270-3901-41
FLANGIA COMPL.

200-4670-03
Guarnizione

1-1770-01
Bullone

264-8965-03
Tappo (12x1,5)

4670-15
Guarnizione

270-3901-27
Flangia

47-1770-07
Bullone (8x1,25) 2

250-7555-07
Rondella 2

270-4730-21
Guarnizione

NOTE - REMARQUES - REMARKS

-Da LDA 96 }
-A partir de } LDA 96 N° 437644
-Starting from } LDAM 96
LDA 97 N° 505954

(a) -Solo LDA 96-97-LDAM 96 e LDA 100 non predispongono avviamento elettrico.
-Seulement LDA 96-97-LDAM 96 et LDA 100 non prédisposent dém. électr.

(b) -Solo LDA 100 predispongono avviamento elettrico e LDA 820.
-Seulement LDA 100 prédisposent dém. électr. et LDA 820.

(c) -LDA 96-97-LDAM 96 e LDA 100 non predispongono avviamento elettrico. N° 5 pezzi LDA 100 predispongono e LDA 820 N° 3 pezzi LDA 96-97-LDAM 96 e LDA 100 non predispongono avviamento elettrico. N° 5 pezzi LDA 100 predispongono e LDA 820 N° 3 pezzi LDA 96-97-LDAM 96 and LDA 100 not suitable for el. start. N° 5 pieces; LDA 100 suitable and LDA 820 N° 3 pieces

(d) -Solo LDA 100 predispongono avviamento elettrico e LDA 820.
-Seulement LDA 100 prédisposent dém. électr. et LDA 820.

-Only LDA 100 suitable for el. start. and LDA 820.

* NON FORNITO SCIOLTO
NON LIVRE SEPARÉMENT
NOT SUPPLIED SEPARATELY

COMPLESSIVO · GROUPE · ASSEMBLY	BASAMENTO POMPA ALIMENTAZ. E EQUILIBRAT. CARTER MOTEUR POMPE D'ALIMENT. ET EQUILIBR. CRANK. FUEL FEEDING PUMP AND DYN. BALANC.	TAVOLA TABLE	4	21	5
MOTORE O VERSIONE MOTEUR OU ADAPTATION ENGINE OR VERSION		FOGLIO FEUILLE PAGE	1	2	
		DATA DATE	2-73		

270-3206-15
Dado 4

270-7625-28
Rondella 4

272-1511-72
BASAMENTO COMPL. LDA 96-97.

279-1511-84
BASAMENTO COMPL. LDA 100.

291-1512-05
BASAMENTO COMPL. LDA 820.

270-4400-05
Asta livello LDA 96-97-100.

291-4400-45
Asta livello LDA 820.

270-6850-24
Prigioniero 2

270-6850-40
Prigioniero 2

270-3334-35
Decalcomania

* **272-1511-53**
Basamento LDA 96-97.

* **279-1511-52**
Basamento LDA 100.

* **291-1512-02**
Basamento LDA 820.

270-6800-53
Prigioniero (10x1,5) 6

443-6800-10
Prigioniero (10x1,5) 5

236-6780-12
Prigioniero (8x1,25) 2

270-6800-55
Prigioniero (10x1,5)

279-6800-59
Prigioniero

270-1610-09
Bronzina

270-1610-58
Bronzina - 0,50

270-1610-10
Bronzina - 1

270-8460-54
Spina

236-6800-18
Prigioniero (10x1,5) 2

270-3901-41
FLANGIA COMPL.

200-4670-03
Guarnizione

1-1770-01
Bullone

264-8965-03
Tappo (12x1,5)

4670-15
Guarnizione

270-3901-27
Flangia

47-1770-07
Bullone (8x1,25) 2

250-7555-07
Rondella 2

270-4730-21
Guarnizione

NOTE - REMARQUES - REMARKS

-Per i motori non predisposti filtro olio, oltre al basamento fornire tubo aspirazione 270-9320-46.

-Pour moteurs non prédisposés pour filtre huile: avec carter livrer tuyau aspir. 270-9320-46.

-Engines not suitable for oil filter: supply crankcase and suction tube 270-9320-46.

* NON FORNITO SCIOLTO
NON LIVRE SEPARÉMENT
NOT SUPPLIED SEPARATELY

COMPLESSIVO · GROUPE · ASSEMBLY	BASAMENTO POMPA ALIMENTAZ. E EQUILIBRAT. CARTER MOTEUR POMPE D'ALIMENT. ET EQUILIBR. CRANK. FUEL FEEDING PUMP AND DYN. BALANC.	TAVOLA TABLE	4	21	5
MOTORE O VERSIONE MOTEUR OU ADAPTATION ENGINE OR VERSION		FOGLIO FEUILLE PAGE	2	2	
		DATA DATE	2-73		



264-8990-08
Tappo

25-1210-31
Anello tenuta

202-7565-11
Rondella 6

3-3240-33
Dado (10x15) 6

270-4775-11
Guarnizione 2

270-4431-10
Guarnizione 0.10 2

270-4431-04
Guarnizione 0.30 2

271-1710-32
Bronzina

271-1710-43
Bronzina - 1

270-6645-31
Portina

270-6645-68
Portina

NOTE - REMARQUES - REMARKS

(a) -Fino a } LDA 96 n° 534062
-Jusqu'au } LDAM96 n° 534063
-Below } LDA 97 n° 505953

(b) -Da } LDA 96 n° 534063
-A partir de } LDAM96 n° 534063
-Starting from } LDA 97 n° 505954

* NON FORNITO SCIOLTO
NON LIVRE SEPAREMENT
NOT SUPPLIED SEPARATELY

COMPLESSIVO - GROUPE - ASSEMBLY		TAVOLA TABLE	4	21	6
MOTORE O VERSIONE MOTEUR OU ADAPTATION ENGINE OR VERSION		FOGLIO FEUILLE PAGE			
PORTINA LATO DISTRIBUZIONE COUVERCLE COTE DISTRIBUTION COVER GEAR TRAIN SIDE		DATA DATE	2-73		

*** 270-8675-67**
Supporto

272-1610-25
Bronzina

272-1610-57
Bronzina -0.50

272-1610-26
Bronzina -1

270-1610-21
Bronzina

270-1610-22
Bronzina -1

270-8460-54
Spina

271-8460-09
Spina

*** 4700-74**
Guarnizione 0.10 2

*** 270-4700-08**
Guarnizione 0.30 2

206-7625-19
Rondella 6

202-7565-11
Rondella 6

3-3240-33
Dado (10x15) 6

270-1210-78
Anello tenuta

270-1210-83
Anello tenuta -1

270-8675-72
SUPPORTO COMPL.

270-8675-79
SUPPORTO COMPL.-0.50

270-8675-73
SUPPORTO COMPL.-1

271-9680-06
VALVOLINA COMPL.

238-1760-03
Bullone (6x1) 2

271-5110-84
Lamierino

271-3895-05
Flangia

271-5755-26
Molla

250-8245-05
Sfera

271-2860-15
Corpo

271-4760-07
Guarnizione

NOTE - REMARQUES - REMARKS

(a) -Fino a } LDA 96 n° 497765
-Jusqu'au } LDAM96 n° 497766
-Below } LDA 97 n° 506039

(b) -Da } LDA 96 n° 497766
-A partir de } LDAM96 n° 497766
-Starting from } LDA 97 n° 506040

(c) -Motori non predisposti avvia-
ment. elettr.
-Moteur non prédisposé dém. électr.
-Engine not suitable for el.
starting.

* NON FORNITO SCIOLTO
NON LIVRE SEPAREMENT
NOT SUPPLIED SEPARATELY

COMPLESSIVO - GROUPE - ASSEMBLY		TAVOLA TABLE	4	21	7
MOTORE O VERSIONE MOTEUR OU ADAPTATION ENGINE OR VERSION		FOGLIO FEUILLE PAGE			
SUPPORTO CUSCINETTO LATO VOLANO SUPPORT ROULEMENT COTE VOLANT BEARING SUPPORT FLYWHEEL SIDE		DATA DATE	2-73		



CATALOGO GENERALE RICAMBI

		<p>NOTE - REMARQUES - REMARKS</p> <p>(a) -Fino a } LDA 96 N° 505332 -Jusqu'au } LDAM96 -Below } LDA 97 N° 510732</p> <p>(b) -Da } LDA 96 N° 505333 -A partir de } LDAM96 -Starting from } LDA 97 N° 510735</p>												
		<p>* NON FORNITO SCIOLTO NON LIVRE SEPAREMENT NOT SUPPLIED SEPARATELY</p>												
<p>270-6645-14 Portina</p> <p>270-6645-40 Portina</p> <p>1-7565-07 Rondella 10</p> <p>202-4770-02 Bullone (Øx1.25) 10</p>	<p>(a) 270-4600-11 Guarnizione</p> <p>(b) 270-4600-91 Guarnizione</p> <p>25-8965-05 Tappo (12x15)</p> <p>1-4670-16 Guarnizione</p>													
<p>COMPLESSIVO - GROUPE - ASSEMBLY</p>		<p>PORTINA DI FONDO (COPPA OLIO) CARTER D'HUILE OIL PAN</p>												
<p>MOTORE O VERSIONE MOTEUR OU ADAPTATION ENGINE OR VERSION</p>		<table border="1" style="width: 100%; border-collapse: collapse;"> <tr> <td>TAVOLA TABLE</td> <td style="text-align: center;">4</td> <td style="text-align: center;">21</td> <td style="text-align: center;">8</td> </tr> <tr> <td>FOGLIO FEUILLE PAGE</td> <td></td> <td></td> <td></td> </tr> <tr> <td>DATA DATE</td> <td colspan="3" style="text-align: center;">2-73</td> </tr> </table>	TAVOLA TABLE	4	21	8	FOGLIO FEUILLE PAGE				DATA DATE	2-73		
TAVOLA TABLE	4	21	8											
FOGLIO FEUILLE PAGE														
DATA DATE	2-73													

		<p>NOTE - REMARQUES - REMARKS</p>												
		<p>* NON FORNITO SCIOLTO NON LIVRE SEPAREMENT NOT SUPPLIED SEPARATELY</p>												
<p>272-2380-10 Cilindro LDA 96-97-LDAM 96.</p> <p>279-2380-55 Cilindro LDA 100.</p> <p>291-2380-82 Cilindro LDA 820.</p>	<p>272-4410-08 * Guarnizione LDA 96-97- LDAM 96. 0.10 3</p> <p>272-4410-17 * Guarnizione LDA 96-97- LDAM 96. 0.30</p> <p>279-4410-23 * Guarnizione LDA 100. 0.10 3</p> <p>279-4410-24 * Guarnizione LDA 100. 0.30</p> <p>291-4410-37 * Guarnizione LDA 820. 0.10 3</p> <p>291-4410-38 * Guarnizione LDA 820. 0.30</p>													
<p>COMPLESSIVO - GROUPE - ASSEMBLY</p>		<p>CILINDRO CYLINDRE CYLINDER</p>												
<p>MOTORE O VERSIONE MOTEUR OU ADAPTATION ENGINE OR VERSION</p>		<table border="1" style="width: 100%; border-collapse: collapse;"> <tr> <td>TAVOLA TABLE</td> <td style="text-align: center;">4</td> <td style="text-align: center;">22</td> <td style="text-align: center;">1</td> </tr> <tr> <td>FOGLIO FEUILLE PAGE</td> <td></td> <td></td> <td></td> </tr> <tr> <td>DATA DATE</td> <td colspan="3" style="text-align: center;">2-73</td> </tr> </table>	TAVOLA TABLE	4	22	1	FOGLIO FEUILLE PAGE				DATA DATE	2-73		
TAVOLA TABLE	4	22	1											
FOGLIO FEUILLE PAGE														
DATA DATE	2-73													



CATALOGO GENERALE RICAMBI

<p>270-4845-05 Guida valvola aspiraz.</p> <p>270-4845-36 Guida valvola aspiraz. ø e +0.50</p> <p>270-6800-50 Prigioniero (10x1.5) 2</p> <p>262-8000-12 Sede valvola aspiraz.</p> <p>262-8000-16 Sede valvola scarico</p> <p>270-6800-50 Prigioniero (10x1.5) 2</p>		<p>291-1160-13 Anello</p> <p>270-4845-46 Guida valvola scarico</p> <p>27-6780-18 Prigioniero (8x1.25) 2</p> <p>270-3206-15 Dado 4</p> <p>270-7625-28 Rondella 4</p> <p>260-8990-07 Tappo</p>	<p>NOTE - REMARQUES - REMARKS</p> <p>-Fino a LDA 96 N° 761606 -Jusqu'au LDAM 96 -Below LDA 97 N° 779625 LDA 100 N° 789945</p> <p>* NON FORNITO SCIOLTO NON LIVRE SEPAREMENT NOT SUPPLIED SEPARATELY</p>
--	--	--	---

COMPLESSIVO - GROUPE - ASSEMBLY		<p>TESTA CON SEDI E GUIDE CULASSE AVEC SIEGES ET GUIDES CYLINDER HEAD W. SEATS & GUIDES</p>	TAVOLA TABLE	4	22	2
MOTORE O VERSIONE MOTEUR OU ADAPTATION ENGINE OR VERSION	LDA96-97-100- LDAM 96		FOGLIO FEUILLE PAGE			
		DATA DATE	2-73			

<p>291-1160-13 Anello 2</p> <p>270-4845-47 Guida valvola aspiraz.</p> <p>270-6800-50 Prigioniero (10x1.5) 2</p> <p>* 291-9200-98 Testa</p> <p>291-8000-46 Sede valvola aspiraz.</p>		<p>291-4845-46 Guida valvola scarico</p> <p>27-6780-18 Prigioniero (8x1.25) 2</p> <p>270-6800-50 Prigioniero (10x1.5) 2</p> <p>291-8000-47 Sede valvola scarico</p>	<p>NOTE - REMARQUES - REMARKS</p> <p>-Da LDA 96 N° 761607 -A partir de LDAM 96 -Starting from LDA 97 N° 779626 LDA 100 N° 789946</p> <p>-Motori matricole precedenti: fornire testa compl. 291-9201-03 -Moteur avec matr. inférieure: livrer cul. compl. 291-9201-03. -S. Nos below : supply compl. cyl. head 291-9201-03.</p> <p>* NON FORNITO SCIOLTO NON LIVRE SEPAREMENT NOT SUPPLIED SEPARATELY</p>
--	--	---	--

COMPLESSIVO - GROUPE - ASSEMBLY		<p>TESTA CON SEDI E GUIDE CULASSE AVEC SIEGES ET GUIDES CYLINDER HEAD W. SEATS & GUIDES</p>	TAVOLA TABLE	4	22	3
MOTORE O VERSIONE MOTEUR OU ADAPTATION ENGINE OR VERSION	291-9201-04		FOGLIO FEUILLE PAGE			
		DATA DATE	2-73			



NOTE - REMARQUES - REMARKS

(a) (b) (c)
 -Per i motori fino a :
 -Pour les moteurs jusqu'au :
 -For engines below :
 LDA 96 N° 761606
 LDAM96 N° 779625
 LDA 97 N° 789945
 LDA 100 N° 789945

-Vedi Tav. (a) 4-35-3
 -Voir Table (b) 4-33-1
 -See Table (c) 4-22-2

(d) (e)
 -Per i motori da :
 -Pour les moteurs a partir de :
 -For engines starting from :
 LDA 96 N° 761607
 LDAM96 N° 779626
 LDA 97 N° 789946
 LDA 100 N° 789946

-Vedi Tav. (d) 4-33-2
 -Voir Table (e) 4-35-4

(f) -Da LDA96 N°989193
 -A partir de LDAM96 N°989513
 -Starting from LDA100 N°933866
 LDA820 N°933866

* NON FORNITO SCOLTO
 NON LIVRE SEPARMENT
 NOT SUPPLIED SEPARATELY

COMPLESSIVO - GROUPE - ASSEMBLY	291-9201-03	TESTA COMPLETA CULASSE COMPLETE CYLINDER HEAD ASSEMBLY	TAVOLA TABLE	4	22	4
MOTORE O VERSIONE MOTEUR OU ADAPTATION ENGINE OR VERSION			FOGLIO FEUILLE PAGE			
			DATA DATE	2-73		

NOTE - REMARQUES - REMARKS

-Fino a) LDA 96 N° 505279
 -Jusqu'au) LDAM96 N° 506167
 -Below) LDA 97 N° 506167

* NON FORNITO SCOLTO
 NON LIVRE SEPARMENT
 NOT SUPPLIED SEPARATELY

COMPLESSIVO - GROUPE - ASSEMBLY		CAPPELLO BILANCIERI COUVERCLE CULBUTEURS ROCKER ARM COVER	TAVOLA TABLE	4	22	5
MOTORE O VERSIONE MOTEUR OU ADAPTATION ENGINE OR VERSION	LDA 96-97-LDAM96		FOGLIO FEUILLE PAGE			
			DATA DATE	2-73		

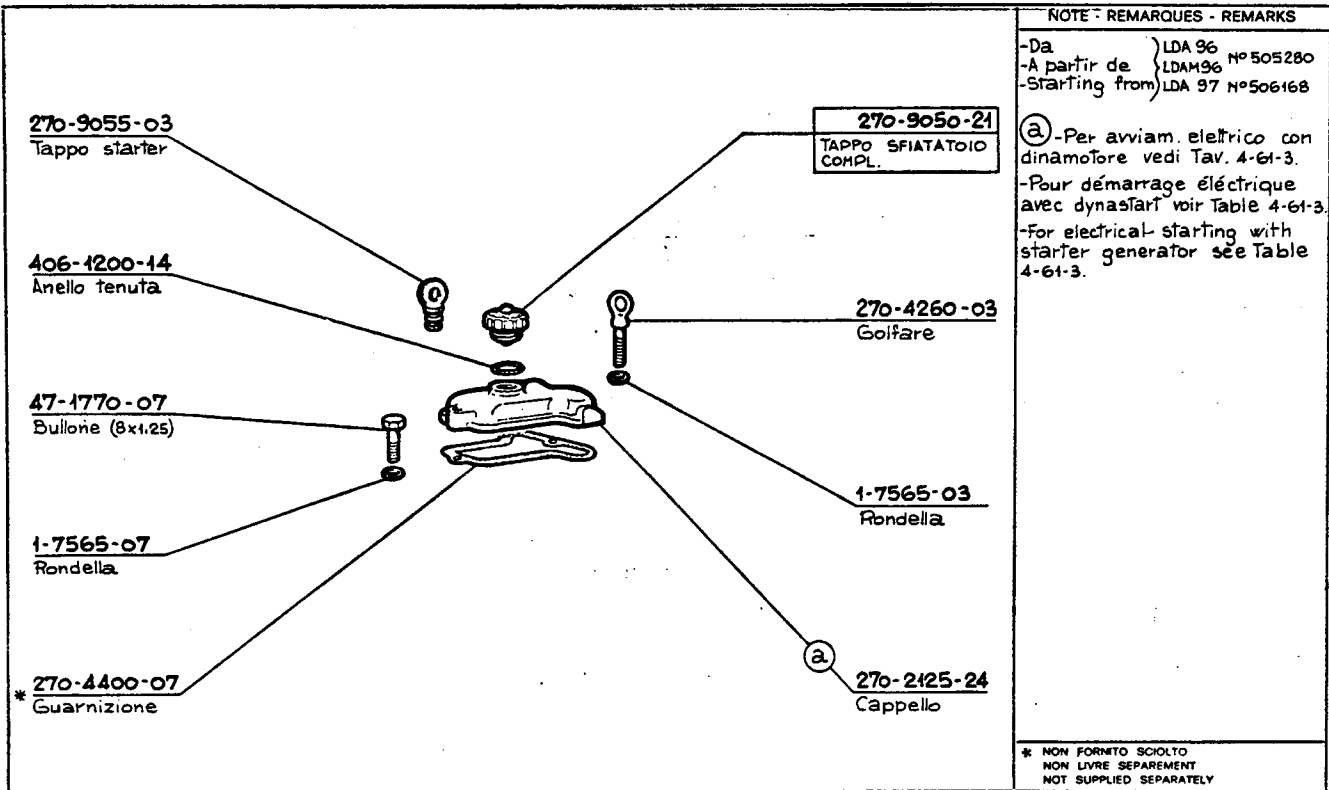

NOTE - REMARQUES - REMARKS

-Da LDA 96 No 505280
 -A partir de LDAM96 No 505280
 -Starting from LDA 97 No 506168

(a) -Per avviam. elettrico con dinamo-tore vedi Tav. 4-61-3.
 -Pour démarrage électrique avec dynastart voir Table 4-61-3.
 -For electrical starting with starter generator see Table 4-61-3.

* NON FORNITO SOLTTO
 NON LIVRE SEPARÉMENT
 NOT SUPPLIED SEPARATELY

COMPLESSIVO - GROUPE - ASSEMBLY		CAPPELLO BILANCIERI COUVERCLE CULBUTEURS ROCKER ARM COVER	TAVOLA TABLE	4	22	6
MOTORE O VERSIONE MOTEUR OU ADAPTATION ENGINE OR VERSION			FOGLIO FEUILLE PAGE			
			DATA DATE	2-73		

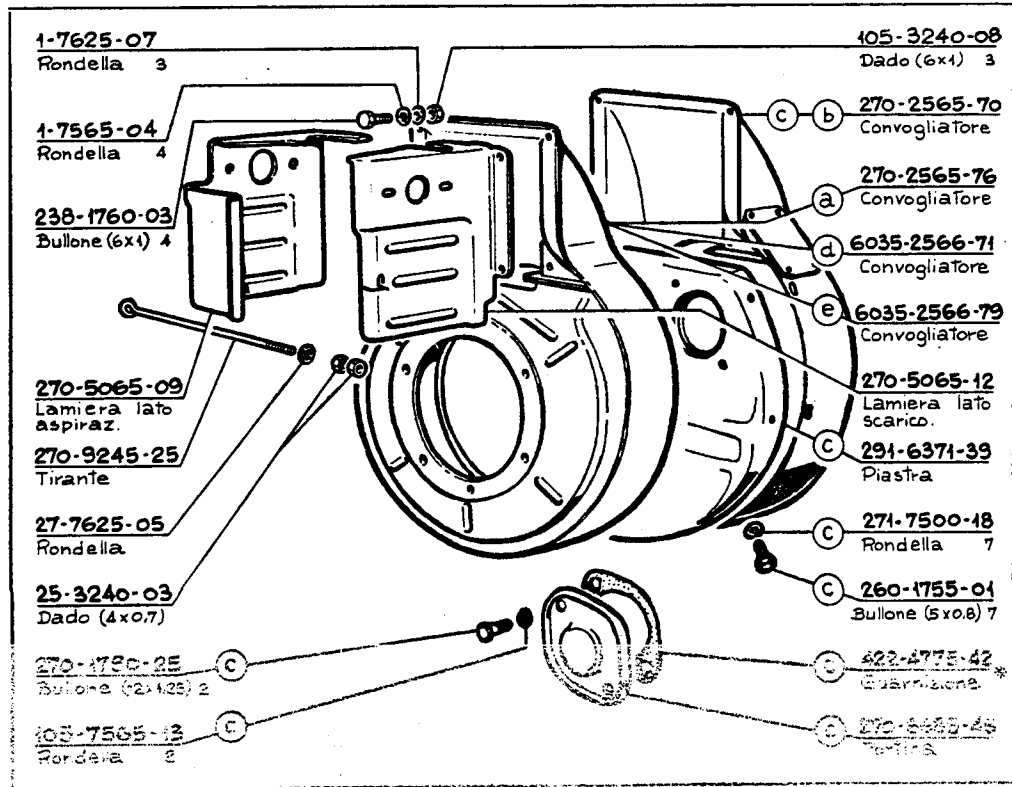

NOTE - REMARQUES - REMARKS

(a) -Solo LDA 96-97-LDAM 96 e LDA 100 non predis. avviam. elettr.
 -Seulement LDA 96-97-LDAM 96 et LDA 100 non predis. dém. électr.
 -Only LDA 96-97-LDAM 96 and LDA 100 not suitable for el. start.

-Fino a LDA 96 No 497765
 -Jusqu'au LDAM 96 No 497765
 -Below LDA 97 No 506039

-Con convogliatore fornire 2 rondelle 271-7500-18.
 -Avec coiffe ventil. livrer 2 rondelles 271-7500-18.
 -With shroud supply 2 washer 271-7500-18.

(b) -LDA 96-97-LDAM 96 avviam. elettrico con motorino.
 -LDA 96-97-LDAM 96 dém. électr. avec démarreur.
 -LDA 96-97-LDAM 96 electr. starting with motor.

-Fino a LDA 96 No 493641
 -Jusqu'au LDAM 96 No 493641
 -Below LDA 97 No 493130

-Vedi Tav. 4-61-2
 -See Table

COMPLESSIVO - GROUPE - ASSEMBLY		LAMIERE E CONVOLIATORE ARIA TOLES ET CONVOYEUR D'AIR SIDE PANELS AND AIR SHROUD	TAVOLA TABLE	4	23	1
MOTORE O VERSIONE MOTEUR OU ADAPTATION ENGINE OR VERSION			FOGLIO FEUILLE PAGE	1	2	
			DATA DATE	2-73		



1-7625-07
Rondella 3

1-7565-04
Rondella 4

238-1760-03
Bullone (6x1) 4

270-5065-09
Lamiera lato aspiraz.

270-9245-25
Tirante

27-7625-05
Rondella

25-3240-03
Dado (4x0.7)

270-1790-25
Bullone (12x1.25) 2

105-7565-13
Rondella 2

105-3240-08
Dado (6x1) 3

270-2565-70
Convogliatore

270-2565-76
Convogliatore

6035-2566-71
Convogliatore

6035-2566-79
Convogliatore

270-5065-12
Lamiera lato scarico.

294-6371-39
Piastra

271-7500-18
Rondella 7

260-1755-01
Bullone (5x0.8) 7

422-4775-42
Guarnizione *

270-6665-45
Portina.

NOTE - REMARQUES - REMARKS

(C) - LDA 96-97-100 - LDAM 96 avviam elettrico con motorino; LDA 100 predisposto avviam. elettrico.
-LDA 96-97-100 - LDAM 96 dém. électr. avec démarreur; LDA 100 prédisp. dém. électr.
-LDA 96-97-100 - LDAM 96 el. start. with motor; LDA 100 suitable el. start.

-Da LDA 96
-A partir de LDAM 96 N°493642
-Starting from LDA 97 N°493131

(d) -Solo avviam. a manovella vedi Tav. 4-68-3.
-Seulement lancement par manivelle voir Table 4-68-3.
-Only hand crank starting see Table 4-68-3.

(e) -Solo avviam. a manovella vedi Tav. 4-68-4.
-Seulement lancement par manivelle voir Table 4-68-4.
-Only hand crank starting see Table 4-68-4.

* NON FORNITO SCOLTO
NON LIVRE SEPARÉMENT
NOT SUPPLIED SEPARATELY

COMPLESSIVO - GROUPE - ASSEMBLY		TAVOLA TABLE	4	23	1
MOTORE O VERSIONE MOTEUR OU ADAPTATION ENGINE OR VERSION		FOGLIO FEUILLE PAGE	2	2	
		DATA DATE	2-73		

**LAMIERE E CONVOGLIATORE ARIA
TOLES ET CONVOYEUR D' AIR
SIDE PANELS AND AIR SHROUD**

270-6426-10
Piede 2

202-7565-41
Rondella 8

406-1780-05
Bullone (10x1.5) 8

NOTE - REMARQUES - REMARKS

* NON FORNITO SCOLTO
NON LIVRE SEPARÉMENT
NOT SUPPLIED SEPARATELY

COMPLESSIVO - GROUPE - ASSEMBLY		TAVOLA TABLE	4	24	1
MOTORE O VERSIONE MOTEUR OU ADAPTATION ENGINE OR VERSION	LDA 96-97-100-820 (K.9961.03)	FOGLIO FEUILLE PAGE			
		DATA DATE	2-73		

**PIEDI STANDARD
PIEDS STANDARD
STANDARD ENGINE MOUNTS**



CATALOGO GENERALE RICAMBI

		<p>NOTE - REMARQUES - REMARKS</p> <p>-Ved: anche Tav. } -Voir aussi Table } 4-71-1 -See also Table }</p>												
<p>406-1780-05 Bullone (40x1,5) 4</p> <p>202-7565-11 Rondella 4</p> <p>6398-6426-54 Piede invertitore</p>	<p>604-6426-55 Piede aspiraz.</p> <p>604-6426-56 Piede scarico</p> <p>202-7565-11 Rondella 4</p> <p>406-1780-08 Bullone (40x1,5) 4</p>													
<p>COMPLESSIVO - GROUPE - ASSEMBLY</p>		<p>NON FORNITO SCIOLTO NON LIVRE SEPAREMENT NOT SUPPLIED SEPARATELY</p>												
<p>MOTORE O VERSIONE MOTEUR OU ADAPTATION ENGINE OR VERSION</p>	<p>LDAM 96 (K. 9961.06)</p>	<p>PIEDI VERSIONE MARINA PIEDS VERSION MARINE MARINE VERSION ENGINE MOUNTS</p>												
		<table border="1" style="border-collapse: collapse;"> <tr> <td>TAVOLA TABLE</td> <td style="text-align: center;">4</td> <td style="text-align: center;">24</td> <td style="text-align: center;">2</td> </tr> <tr> <td>FOGLIO FEUILLE PAGE</td> <td></td> <td></td> <td></td> </tr> <tr> <td>DATA DATE</td> <td></td> <td></td> <td style="text-align: center;">2-73</td> </tr> </table>	TAVOLA TABLE	4	24	2	FOGLIO FEUILLE PAGE				DATA DATE			2-73
TAVOLA TABLE	4	24	2											
FOGLIO FEUILLE PAGE														
DATA DATE			2-73											

		<p>NOTE - REMARQUES - REMARKS</p>												
<p>202-1780-06 Bullone (40x1,5) 8</p> <p>202-7565-11 Rondella 8</p> <p>6398-6426-49 Piede aspiraz.</p> <p>6398-6426-49 Piede scarico</p>	<p>6398-6426-50 Piede</p> <p>6398-6426-48 Piede</p> <p>6520-8625-70 Supporto 4</p> <p>105-7565-13 Rondella 8</p> <p>9-3240-40 Dado (42x1,5) 8</p>													
<p>COMPLESSIVO - GROUPE - ASSEMBLY</p>		<p>NON FORNITO SCIOLTO NON LIVRE SEPAREMENT NOT SUPPLIED SEPARATELY</p>												
<p>MOTORE O VERSIONE MOTEUR OU ADAPTATION ENGINE OR VERSION</p>	<p>LDA 96-97-100-820 (K. 9961.01)</p>	<p>PIEDI ELASTICI PIEDS ELASTIQUES SOFT MOUNTS</p>												
		<table border="1" style="border-collapse: collapse;"> <tr> <td>TAVOLA TABLE</td> <td style="text-align: center;">4</td> <td style="text-align: center;">24</td> <td style="text-align: center;">3</td> </tr> <tr> <td>FOGLIO FEUILLE PAGE</td> <td></td> <td></td> <td></td> </tr> <tr> <td>DATA DATE</td> <td></td> <td></td> <td style="text-align: center;">2-73</td> </tr> </table>	TAVOLA TABLE	4	24	3	FOGLIO FEUILLE PAGE				DATA DATE			2-73
TAVOLA TABLE	4	24	3											
FOGLIO FEUILLE PAGE														
DATA DATE			2-73											

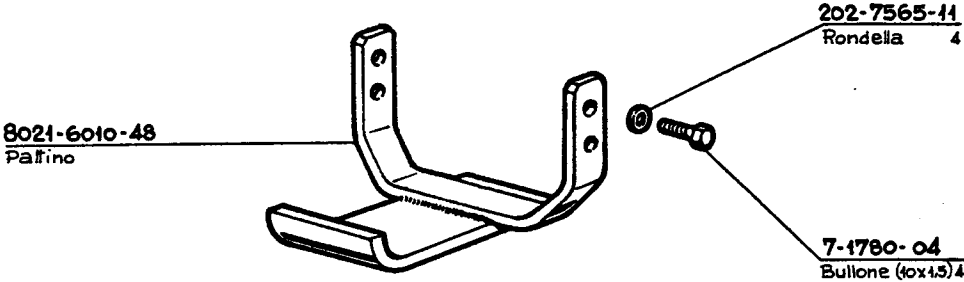

		NOTE - REMARQUES - REMARKS	
		* NON FORNITO SCOLTO NON LIVRE SEPAREMENT NOT SUPPLIED SEPARATELY	
8021-6010-48 Pattino		202-7565-11 Rondella 4	
		7-1780-04 Bullone (4x15)4	
COMPLESSIVO - GROUPE - ASSEMBLY			TAVOLA TABLE 4 29 1
MOTORE O VERSIONE MOTEUR OU ADAPTATION ENGINE OR VERSION	LDA 96-97-100-820 (K. 9967.63)	PATTINO PROTEZIONE PATIN PROTECTION GUARD PAD	FOGLIO FEUILLE PAGE DATA DATE 2-73

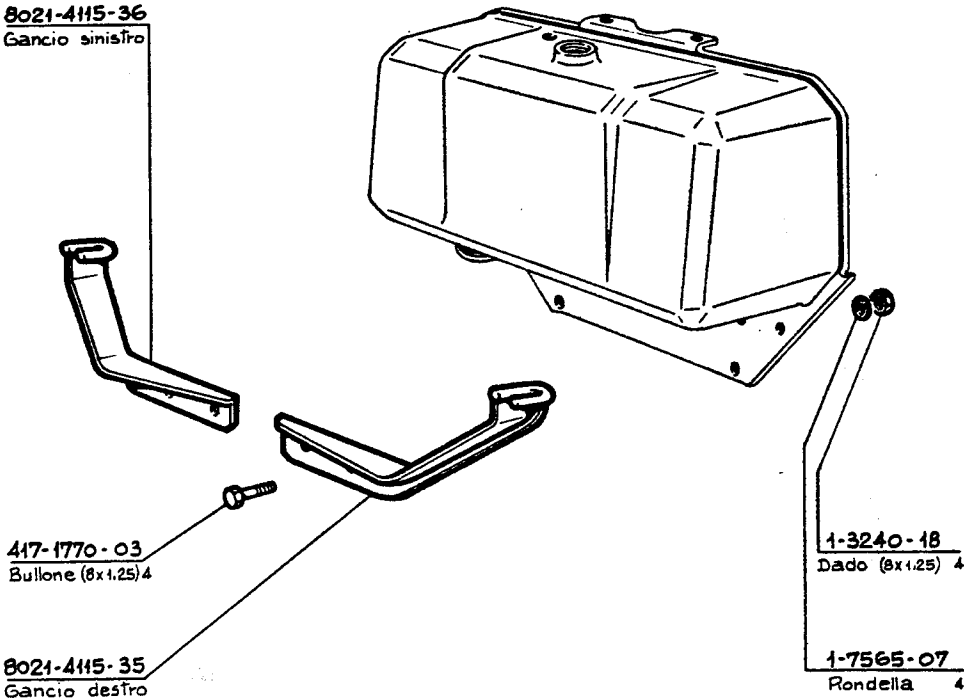
		NOTE - REMARQUES - REMARKS	
		* NON FORNITO SCOLTO NON LIVRE SEPAREMENT NOT SUPPLIED SEPARATELY	
8021-4115-36 Gancio sinistro		1-7565-07 Rondella 4	
417-1770-03 Bullone (8x1.25)4		1-3240-18 Dado (8x1.25) 4	
8021-4115-35 Gancio destro			
COMPLESSIVO - GROUPE - ASSEMBLY			TAVOLA TABLE 4 29 2
MOTORE O VERSIONE MOTEUR OU ADAPTATION ENGINE OR VERSION	LDA 96-97-100-820 (K. 9967.14)	GANCI COFANO CROCHETS DU CAPOT HOOD HOOKS	FOGLIO FEUILLE PAGE DATA DATE 2-73



<p>291-4051-11 ALBERO COMPL. LDA 820.</p> <p>270-9000-42 Tappo</p> <p>270-6330-47 Piastra</p> <p>238-1755-02 Bullone (5x0,8) 2</p> <p>291-2280-49 Chiavetta</p> <p>270-2200-09 Chiavetta</p> <p>270-1860-74 Bullone LDA 96- 97-100-LDAM 96.</p> <p>291-1862-12 Bullone LDA 820</p> <p>25-1210-31 Anello tenuta</p>		<p>270-4050-07 ALBERO COMPL. LDA 96-97-100- LDAM 96.</p> <p>57-8990-02 Tappo</p> <p>291-2280-56 Chiavetta</p> <p>270-2210-25 Chiavetta</p> <p>270-1210-78 Anello tenuta</p> <p>270-1210-83 Anello tenuta -1</p> <p>270-4050-06 * Albero LDA 96- 97-100-LDAM 96.</p> <p>291-4051-08 * Albero LDA 820</p>	<p>NOTE - REMARQUES - REMARKS</p> <p>-Versione industriale. -Version industrielle. -Industrial version.</p> <p>(a) -Fino a } LDA 96 n° 779114 -Jusqu'au } LDAM 96 n° 825323 -Below } LDA 97 n° 825323 } LDA 100 n° 760580</p> <p>(b) -Da } LDA 96 n° 779115 -A partir de } LDAM 96 n° 825324 -Starting from } LDA 97 n° 825324 } LDA 100 n° 760581</p> <p>* NON FORNITO SCIOLTO NON LIVRE SEPAREMENT NOT SUPPLIED SEPARATELY</p>												
<p>COMPLESSIVO - GROUPE - ASSEMBLY</p>		<p>ALBERO A GOMITO VILEBREQUIN CRANKSHAFT</p>													
<p>MOTORE O VERSIONE MOTEUR OU ADAPTATION ENGINE OR VERSION</p>			<table border="1" style="width:100%; border-collapse: collapse;"> <tr> <td>TAVOLA TABLE</td> <td style="text-align: center;">4</td> <td style="text-align: center;">31</td> <td style="text-align: center;">1</td> </tr> <tr> <td>FOGLIO FEUILLE PAGE</td> <td></td> <td></td> <td></td> </tr> <tr> <td>DATA DATE</td> <td colspan="3" style="text-align: center;">2-73</td> </tr> </table>	TAVOLA TABLE	4	31	1	FOGLIO FEUILLE PAGE				DATA DATE	2-73		
TAVOLA TABLE	4	31	1												
FOGLIO FEUILLE PAGE															
DATA DATE	2-73														

<p>291-4051-12 ALBERO COMPL. LDA 820.</p> <p>270-9000-42 Tappo</p> <p>270-6330-47 Piastra</p> <p>238-1755-02 Bullone (5x0,8) 2</p> <p>291-2280-49 Chiavetta</p> <p>270-2200-09 Chiavetta</p> <p>1860-92 Bullone LDA 96- 97-100-LDAM 96.</p> <p>6016-1862-13 Bullone LDA 820</p> <p>270-1210-77 Anello tenuta</p>		<p>270-4050-05 ALBERO COMPL. LDA 96-97-100- LDAM 96.</p> <p>57-8990-02 Tappo</p> <p>291-2280-56 Chiavetta</p> <p>270-2210-25 Chiavetta</p> <p>270-1210-78 Anello tenuta</p> <p>270-1210-83 Anello tenuta -1</p> <p>270-4050-19 * Albero LDA 96-97- 100-LDAM 96.</p> <p>291-4050-93 * Albero LDA 820.</p>	<p>NOTE - REMARQUES - REMARKS</p> <p>-Versione autotrazione. -Version autotraction. -Automotive version.</p> <p>(a) -Fino a } LDA 96 n° 779164 -Jusqu'au } LDA 97 n° 825323 -Below } LDA 100 n° 824286</p> <p>(b) -Da } LDA 96 n° 779165 -A partir de } LDA 97 n° 825324 -Starting from } LDA 100 n° 824287</p> <p>* NON FORNITO SCIOLTO NON LIVRE SEPAREMENT NOT SUPPLIED SEPARATELY</p>												
<p>COMPLESSIVO - GROUPE - ASSEMBLY</p>		<p>ALBERO A GOMITO VILEBREQUIN CRANKSHAFT</p>													
<p>MOTORE O VERSIONE MOTEUR OU ADAPTATION ENGINE OR VERSION</p>	<p>LDA 96-97-100-820</p>		<table border="1" style="width:100%; border-collapse: collapse;"> <tr> <td>TAVOLA TABLE</td> <td style="text-align: center;">4</td> <td style="text-align: center;">31</td> <td style="text-align: center;">2</td> </tr> <tr> <td>FOGLIO FEUILLE PAGE</td> <td></td> <td></td> <td></td> </tr> <tr> <td>DATA DATE</td> <td colspan="3" style="text-align: center;">2-73</td> </tr> </table>	TAVOLA TABLE	4	31	2	FOGLIO FEUILLE PAGE				DATA DATE	2-73		
TAVOLA TABLE	4	31	2												
FOGLIO FEUILLE PAGE															
DATA DATE	2-73														



270-9881-28
VOLANO COMPL. (C)

* **270-9881-06**
Volano

270-2816-41
Corona

203-7540-04
Rondella 4 (b)

3-7540-06
Rondella 4 (c)

25-9810-07
Vite (6x1) 4 (b)

273-9810-12
Vite (8x125) 4 (c)

270-9881-03
Volano (a)

270-5095-57
Lamiera LDA 96-97-100-LDAM 96.

291-5095-81
Lamiera LDA 820.

270-5095-58
Lamiera LDA 96-97-LDAM 96. (d)

270-6960-10
Puleggia (4 fori)

270-6960-61
Puleggia (6 fori)

6446-6960-54
Puleggia (6 fori) (e)

250-7555-07
Rondella 6

1-1770-06
Bullone (8x125)6

270-1860-11
Bullone

NOTE - REMARQUES - REMARKS

(a) -Solo LDA 96-97-LDAM 96 e LDA 100 non predis. avviam. elettr.
-Seulement LDA 96-97-LDAM 96 et LDA 100 non predis. dém. électr.
-Only LDA 96-97-LDAM 96 and LDA 100 not suitable for el. start.

-Fino a LDA 96
-jusqu'au LDAM 96 N° 497765
-Below LDA 97 N° 506039

-Per LDA 96-97-LDAM 96 fornire col volano N° 4 viti 273-9810-12 e N° 4 rondelle 3-7540-06.

-Pour LDA 96-97-LDAM 96 livrer avec volant N° 4 vis 273-9810-12 et N° 4 rondelles 3-7540-06.

-For LDA 96-97-LDAM 96 supply N° 4 screws and N° 4 washers with flywheel.

(b) -Fino a LDA 96
-jusqu'au LDAM 96 N° 497765
-Below LDAM 97 N° 506039

(c) -Da LDA 96 N° 493642
-A partir de LDAM 96
-Starting from LDA 97 N° 493130

* NON FORNITO SCIOLTO
NON LIVRE SEPAREMENT
NOT SUPPLIED SEPARATELY

COMPLESSIVO - GROUPE - ASSEMBLY		TAVOLA TABLE	4	31	3
MOTORE O VERSIONE MOTEUR OU ADAPTATION ENGINE OR VERSION		FOGLIO FEUILLE PAGE	1	2	
VOLANO - PULEGGIA - LAMIERA PROTEZIONE VOLANT - POULIE - TOLE PROTECTION FLYWHEEL - PULLEY - GUARD PANEL		DATA DATE	2-73		

270-9881-28
VOLANO COMPL. (C)

* **270-9881-06**
Volano

270-2816-41
Corona

203-7540-04
Rondella 4 (b)

3-7540-06
Rondella 4 (c)

25-9810-07
Vite (6x1) 4 (b)

273-9810-12
Vite (8x125) 4 (c)

270-9881-03
Volano (a)

270-5095-57
Lamiera LDA 96-97-100-LDAM 96.

291-5095-81
Lamiera LDA 820.

270-5095-58
Lamiera LDA 96-97-LDAM 96. (d)

270-6960-10
Puleggia (4 fori)

270-6960-61
Puleggia (6 fori)

6446-6960-54
Puleggia (6 fori) (e)

250-7555-07
Rondella 6

1-1770-06
Bullone (8x125)6

270-1860-11
Bullone

NOTE - REMARQUES - REMARKS

-LDA 96-97-LDAM 96 avviam. elettr. con motorino vedi Tav. 4-61-5/6/7/8/9/10/11 ;
LDA 100 predis. avviam. elettr. avec démarreur voir Table 4-61-5/6/7/8/9/10/11 ;
LDA 100 predis. dém. électr.

-LDA 96-97-LDAM 96 dém. électr. with motor see Table 4-61-5/6/7/8/9/10/11 ;
LDA 100 suitable el. start.

(d) -Solo avviam. elettr. con dinamofores vedi Tav. 4-61-3.
-Seulement dém. électr. avec dynastart voir Table 4-61-3.
-Only electr. starting with starter generator see Table 4-61-3.

(e) -Puleggia avviam. elettr. con dinamofores vedi Tav. 4-61-3.
-Poulie dém. électr. avec dynastart voir Table 4-61-3.
-Pulley electrical starting with starter generator see Table 4-61-3.

* NON FORNITO SCIOLTO
NON LIVRE SEPAREMENT
NOT SUPPLIED SEPARATELY

COMPLESSIVO - GROUPE - ASSEMBLY		TAVOLA TABLE	4	31	3
MOTORE O VERSIONE MOTEUR OU ADAPTATION ENGINE OR VERSION		FOGLIO FEUILLE PAGE	2	2	
VOLANO - PULEGGIA - LAMIERA PROTEZIONE VOLANT - POULIE - TOLE PROTECTION FLYWHEEL - PULLEY - GUARD PANEL		DATA DATE	2-73		

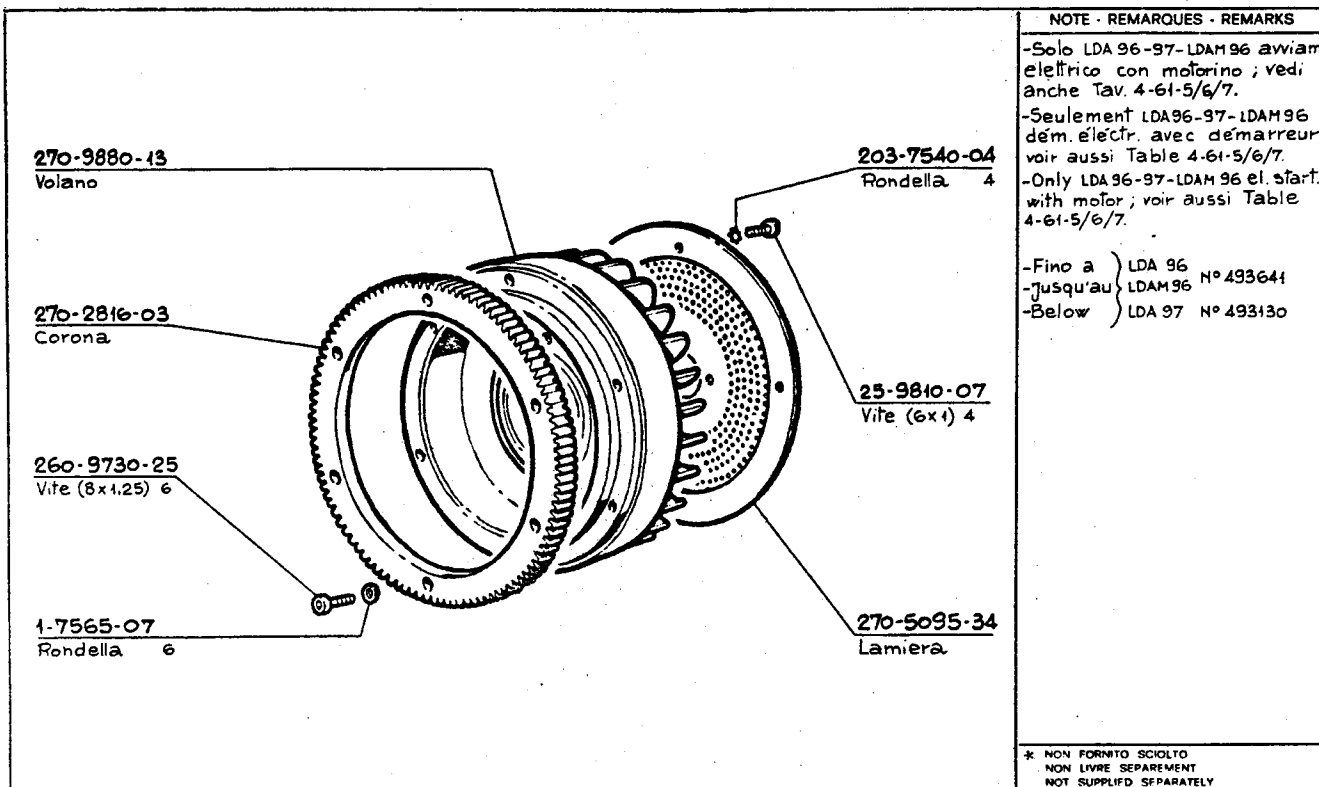

NOTE - REMARQUES - REMARKS

-Solo LDA 96-97-LDAM96 avviamento elettrico con motorino; vedi anche Tav. 4-61-5/6/7.

-Seulement LDA96-97-LDAM96 dém. électr. avec démarreur; voir aussi Table 4-61-5/6/7.

-Only LDA 96-97-LDAM 96 el. start. with motor; voir aussi Table 4-61-5/6/7.

-Fino a) LDA 96
-Jusqu'au) LDAM96 N° 493641
-Below) LDA 97 N° 493130

* NON FORNITO SCIOLTO
NON LIVRE SEPARÉMENT
NOT SUPPLIED SEPARATELY

COMPLESSIVO - GROUPE - ASSEMBLY		VOLANO AVVIAM. ELETTR. CON MOTORINO VOLANT POUR DEM. ELECTR. AVEC DEMARREUR FLYWHEEL FOR ELECTR. STARTING WITH MOTOR		TAVOLA TABLE	4	31	4
MOTORE O VERSIONE MOTEUR OU ADAPTATION ENGINE OR VERSION	LDA 96-97 - LDAM 96			FOGLIO FEUILLE PAGE			
				DATA DATE	2-73		

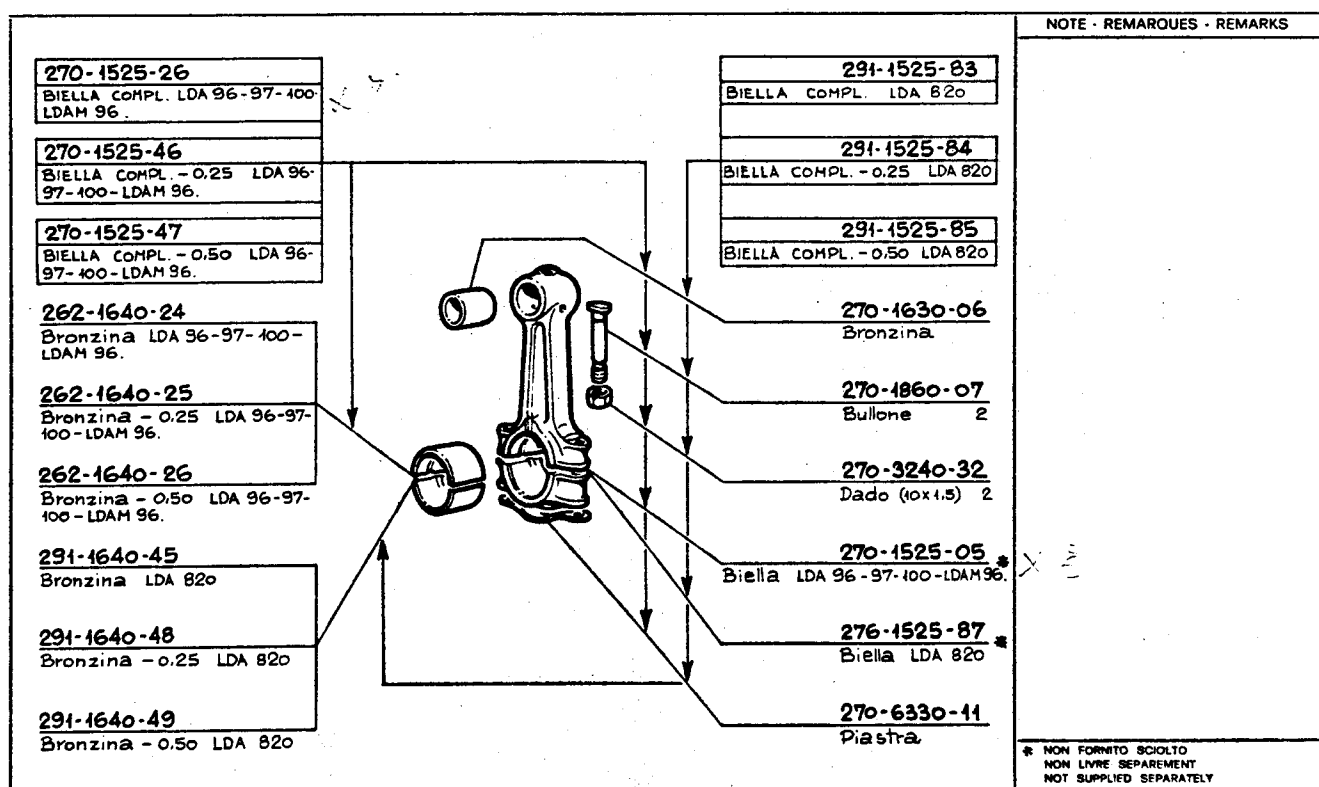

NOTE - REMARQUES - REMARKS

* NON FORNITO SCIOLTO
NON LIVRE SEPARÉMENT
NOT SUPPLIED SEPARATELY

COMPLESSIVO - GROUPE - ASSEMBLY		BIELLA BIELLE CONNECTING ROD		TAVOLA TABLE	4	32	1
MOTORE O VERSIONE MOTEUR OU ADAPTATION ENGINE OR VERSION				FOGLIO FEUILLE PAGE			
				DATA DATE	2-73		



<p>NOTE - REMARQUES - REMARKS</p>																														
<table border="1" style="width: 100%; border-collapse: collapse;"> <tr><td>276-8210-52</td></tr> <tr><td>SERIE SEGMENTI</td></tr> <tr><td> </td></tr> <tr><td>276-8210-53</td></tr> <tr><td>SERIE SEGMENTI +0.50</td></tr> <tr><td> </td></tr> <tr><td>276-8210-54</td></tr> <tr><td>SERIE SEGMENTI +1</td></tr> <tr><td> </td></tr> <tr><td>* 276-8025-58</td></tr> <tr><td>Segmento</td></tr> <tr><td> </td></tr> <tr><td>* 272-8025-09</td></tr> <tr><td>Segmento</td></tr> <tr><td> </td></tr> <tr><td>* 276-8025-85</td></tr> <tr><td>Segmento</td></tr> <tr><td> </td></tr> <tr><td>* 272-8025-17</td></tr> <tr><td>Segmento</td></tr> </table>	276-8210-52	SERIE SEGMENTI		276-8210-53	SERIE SEGMENTI +0.50		276-8210-54	SERIE SEGMENTI +1		* 276-8025-58	Segmento		* 272-8025-09	Segmento		* 276-8025-85	Segmento		* 272-8025-17	Segmento		<p>X 272-6502-21* Pistone</p> <p>272-8480-10 Spinotto</p> <p>270-1240-26 Anello Seeger 2</p> <table border="1" style="width: 100%; border-collapse: collapse;"> <tr><td>272-6500-70</td></tr> <tr><td>PISTONE COMPL.</td></tr> <tr><td> </td></tr> <tr><td>272-6500-71</td></tr> <tr><td>PISTONE COMPL.+0.50</td></tr> <tr><td> </td></tr> <tr><td>272-6500-72</td></tr> <tr><td>PISTONE COMPL.+1</td></tr> </table>	272-6500-70	PISTONE COMPL.		272-6500-71	PISTONE COMPL.+0.50		272-6500-72	PISTONE COMPL.+1
276-8210-52																														
SERIE SEGMENTI																														
276-8210-53																														
SERIE SEGMENTI +0.50																														
276-8210-54																														
SERIE SEGMENTI +1																														
* 276-8025-58																														
Segmento																														
* 272-8025-09																														
Segmento																														
* 276-8025-85																														
Segmento																														
* 272-8025-17																														
Segmento																														
272-6500-70																														
PISTONE COMPL.																														
272-6500-71																														
PISTONE COMPL.+0.50																														
272-6500-72																														
PISTONE COMPL.+1																														
<p>* NON FORNITO SCOLTO NON LIVRE SEPAREMENT NOT SUPPLIED SEPARATELY</p>																														
<p>COMPLESSIVO - GROUPE - ASSEMBLY</p>	<p>PISTONE E SEGMENTI PISTON ET SEGMENTS PISTON AND RINGS</p>	<table border="1" style="width: 100%; border-collapse: collapse;"> <tr> <td>TAVOLA TABLE</td> <td style="text-align: center;">4</td> <td style="text-align: center;">32</td> <td style="text-align: center;">2</td> </tr> <tr> <td>FOGLIO FEUILLE PAGE</td> <td> </td> <td> </td> <td> </td> </tr> <tr> <td>DATA DATE</td> <td colspan="3" style="text-align: center;">2-73</td> </tr> </table>	TAVOLA TABLE	4	32	2	FOGLIO FEUILLE PAGE				DATA DATE	2-73																		
TAVOLA TABLE	4	32	2																											
FOGLIO FEUILLE PAGE																														
DATA DATE	2-73																													
<p>MOTORE O VERSIONE MOTEUR OU ADAPTATION ENGINE OR VERSION</p> <p style="text-align: center;">LDA 96-97- LDAM96</p>																														

<p>NOTE - REMARQUES - REMARKS</p>																											
<table border="1" style="width: 100%; border-collapse: collapse;"> <tr><td>279-8210-49</td></tr> <tr><td>SERIE SEGMENTI</td></tr> <tr><td> </td></tr> <tr><td>279-8210-50</td></tr> <tr><td>SERIE SEGMENTI +0.50</td></tr> <tr><td> </td></tr> <tr><td>279-8210-51</td></tr> <tr><td>SERIE SEGMENTI +1</td></tr> <tr><td> </td></tr> <tr><td>* 279-8025-53</td></tr> <tr><td>Segmento</td></tr> <tr><td> </td></tr> <tr><td>* 279-8025-51</td></tr> <tr><td>Segmento</td></tr> <tr><td> </td></tr> <tr><td>* 279-8025-52</td></tr> <tr><td>Segmento</td></tr> </table>	279-8210-49	SERIE SEGMENTI		279-8210-50	SERIE SEGMENTI +0.50		279-8210-51	SERIE SEGMENTI +1		* 279-8025-53	Segmento		* 279-8025-51	Segmento		* 279-8025-52	Segmento		<p>279-6502-22* Pistone</p> <p>279-8480-21 Spinotto</p> <p>270-1240-26 Anello Seeger 2</p> <table border="1" style="width: 100%; border-collapse: collapse;"> <tr><td>279-6501-21</td></tr> <tr><td>PISTONE COMPL.</td></tr> <tr><td> </td></tr> <tr><td>279-6501-22</td></tr> <tr><td>PISTONE COMPL.+0.50</td></tr> <tr><td> </td></tr> <tr><td>279-6501-23</td></tr> <tr><td>PISTONE COMPL.+1</td></tr> </table>	279-6501-21	PISTONE COMPL.		279-6501-22	PISTONE COMPL.+0.50		279-6501-23	PISTONE COMPL.+1
279-8210-49																											
SERIE SEGMENTI																											
279-8210-50																											
SERIE SEGMENTI +0.50																											
279-8210-51																											
SERIE SEGMENTI +1																											
* 279-8025-53																											
Segmento																											
* 279-8025-51																											
Segmento																											
* 279-8025-52																											
Segmento																											
279-6501-21																											
PISTONE COMPL.																											
279-6501-22																											
PISTONE COMPL.+0.50																											
279-6501-23																											
PISTONE COMPL.+1																											
<p>* NON FORNITO SCOLTO NON LIVRE SEPAREMENT NOT SUPPLIED SEPARATELY</p>																											
<p>COMPLESSIVO - GROUPE - ASSEMBLY</p>	<p>PISTONE E SEGMENTI PISTON ET SEGMENTS PISTON AND RINGS</p>	<table border="1" style="width: 100%; border-collapse: collapse;"> <tr> <td>TAVOLA TABLE</td> <td style="text-align: center;">4</td> <td style="text-align: center;">32</td> <td style="text-align: center;">3</td> </tr> <tr> <td>FOGLIO FEUILLE PAGE</td> <td> </td> <td> </td> <td> </td> </tr> <tr> <td>DATA DATE</td> <td colspan="3" style="text-align: center;">2-73</td> </tr> </table>	TAVOLA TABLE	4	32	3	FOGLIO FEUILLE PAGE				DATA DATE	2-73															
TAVOLA TABLE	4	32	3																								
FOGLIO FEUILLE PAGE																											
DATA DATE	2-73																										
<p>MOTORE O VERSIONE MOTEUR OU ADAPTATION ENGINE OR VERSION</p> <p style="text-align: center;">LDA100</p>																											

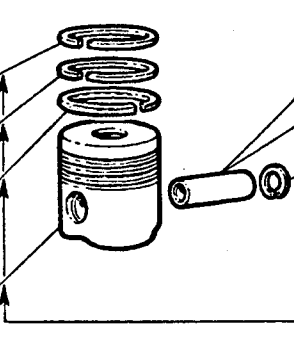

<div style="display: flex; justify-content: space-between;"> <div style="width: 45%;"> <p>291-8210-58 SERIE SEGMENTI</p> <p>291-8210-59 SERIE SEGMENTI +0,50</p> <p>291-8210-60 SERIE SEGMENTI +1</p> <p>* 291-8025-68 Segmento</p> <p>* 291-8025-67 Segmento</p> <p>* 291-8025-69 Segmento</p> <p>* 291-6502-23 Pistone</p> </div> <div style="width: 45%; text-align: right;"> <p>279-8480-21 Spinotto</p> <p>291-8480-25 Spinotto</p> <p>270-1240-26 Anello Seeger 2</p> <p>291-6501-70 PISTONE COMPL.</p> <p>291-6501-71 DISTONE COMPL. +0,50</p> <p>291-6501-72 PISTONE COMPL. + 1</p> </div> </div> 		<p>NOTE - REMARQUES - REMARKS</p> <p>* NON FORNITO SCOLTO NON LIVRE SEPAREMENT NOT SUPPLIED SEPARATELY</p>													
<p>COMPLESSIVO - GROUPE - ASSEMBLY</p>		<p>PISTONE E SEGMENTI PISTON ET SEGMENTS PISTON AND RINGS</p>	<table border="1" style="font-size: small;"> <tr> <td>TAVOLA TABLE</td> <td style="text-align: center;">4</td> <td style="text-align: center;">32</td> <td style="text-align: center;">4</td> </tr> <tr> <td>FOGLIO FEUILLE PAGE</td> <td></td> <td></td> <td></td> </tr> <tr> <td>DATA DATE</td> <td colspan="3" style="text-align: center;">2-73</td> </tr> </table>	TAVOLA TABLE	4	32	4	FOGLIO FEUILLE PAGE				DATA DATE	2-73		
TAVOLA TABLE	4	32	4												
FOGLIO FEUILLE PAGE															
DATA DATE	2-73														
<p>MOTORE O VERSIONE MOTEUR OU ADAPTATION ENGINE OR VERSION</p>	<p>LDA 820</p>														

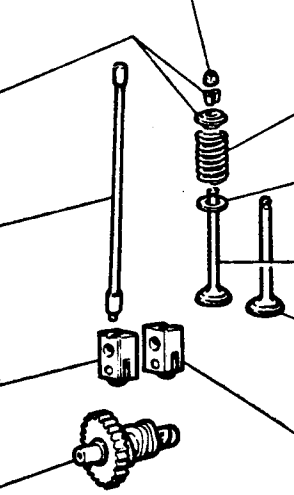
<div style="display: flex; justify-content: space-between;"> <div style="width: 45%;"> <p>270-2135-67 Cappello</p> <p>260-6410-18 Piaffello con semiconi 2</p> <p>270-4410-11 ASTA COMPL. 2</p> <p>270-4887-02 PUNTERIA SCARICO COMPL.</p> <p>291-1010-60 Albero</p> </div> <div style="width: 45%; text-align: right;"> <p>260-5755-04 Molla 2</p> <p>270-3430-18 Disco 2</p> <p>262-9652-05 Valvola aspiraz.</p> <p>262-9685-25 Valvola scarico</p> <p>270-4887-01 PUNTERIA ASPIRAZ. COMPL.</p> </div> </div> 		<p>NOTE - REMARQUES - REMARKS</p> <p>Fino a } LDA 96 N° 761607 Jusqu'au } LDAM 96 N° 779625 Below } LDA 97 N° 789946 } LDA 100 N° 789946</p> <p>* NON FORNITO SCOLTO NON LIVRE SEPAREMENT NOT SUPPLIED SEPARATELY</p>													
<p>COMPLESSIVO - GROUPE - ASSEMBLY</p>		<p>ALBERO A CAMME E VALVOLE ARBRE A CAMES ET SOUPAPES CAMSHAFT AND VALVES</p>	<table border="1" style="font-size: small;"> <tr> <td>TAVOLA TABLE</td> <td style="text-align: center;">4</td> <td style="text-align: center;">33</td> <td style="text-align: center;">1</td> </tr> <tr> <td>FOGLIO FEUILLE PAGE</td> <td></td> <td></td> <td></td> </tr> <tr> <td>DATA DATE</td> <td colspan="3" style="text-align: center;">2-73</td> </tr> </table>	TAVOLA TABLE	4	33	1	FOGLIO FEUILLE PAGE				DATA DATE	2-73		
TAVOLA TABLE	4	33	1												
FOGLIO FEUILLE PAGE															
DATA DATE	2-73														
<p>MOTORE O VERSIONE MOTEUR OU ADAPTATION ENGINE OR VERSION</p>	<p>LDA 96-97-100-LDAM96</p>														



<p>270-2135-67 Cappellofo</p> <p>260-6410-18 Piatello con semiconi 2</p> <p>270-4410-11 ASTA COMPL. 2</p> <p>270-4887-02 PUNTERIA SCARICO COMPL.</p> <p>291-1010-60 Albero</p>		<p>260-5755-04 Molla 2</p> <p>291-3430-57 Disco 2</p> <p>291-9652-19 Valvola aspiraz.</p> <p>291-9685-31 Valvola scarico</p> <p>270-4887-01 PUNTERIA ASPIRAZ. COMPL.</p>		<p>NOTE - REMARQUES - REMARKS</p> <p>-Da LDA 96 N°761608 -A partir de LDAM 96 -Starting from LDA 97 N°779626 LDA 100 N°789947</p>
<p>COMPLESSIVO - GROUPE - ASSEMBLY</p>		<p>* NON FORNITO SCIOLTO NON LIVRE SEPAREMENT NOT SUPPLIED SEPARATELY</p>		
<p>MOTORE O VERSIONE MOTEUR OU ADAPTATION ENGINE OR VERSION</p>		<p>ALBERO A CAMME E VALVOLE ARBRE A CAMES ET SOUPAPES CAMSHAFT AND VALVES</p>		
		<p>TAVOLA TABLE</p>	<p>4 33 2</p>	
		<p>FOGLIO FEUILLE PAGE</p>		
		<p>DATA DATE</p>	<p>2-73</p>	

<p>25-8245-11 Sfera 6</p> <p>270-4884-02 Ingranaggio</p> <p>270-6370-38 Piastra</p> <p>428-1750-01 Bullone (4x0.7) 2</p> <p>270-6275-38 Piastra</p> <p>250-1240-06 Anello Seeger</p>		<p>270-2085-29 Campana</p> <p>3-3240-33 Dado (40x1.5)</p> <p>206-7625-19 Rondella</p> <p>271-6130-16 Perno</p> <p>270-6130-15 Perno</p> <p>270-7700-69 Rondella</p>		<p>NOTE - REMARQUES - REMARKS</p> <p>(a) -Fino a LDA 96 N°525676 -jusqu'au LDAM 96 N°526374 -Below LDA 100 N°528137</p> <p>(b) -Da LDA 96 N°525677 -A partir de LDAM 96 N°526375 -Starting from LDA 97 N°526375 LDA 100 N°528138</p> <p>(c) -Per i motori al punto (b) oltre alla campana fornire la rondella 270-7700-69. -Pour les moteurs (b) livrer cloche avec rondelle 270-7700-69. -For engines (b) supply bell with washer 270-7700-69.</p>
<p>COMPLESSIVO - GROUPE - ASSEMBLY</p>		<p>* NON FORNITO SCIOLTO NON LIVRE SEPAREMENT NOT SUPPLIED SEPARATELY</p>		
<p>MOTORE O VERSIONE MOTEUR OU ADAPTATION ENGINE OR VERSION</p>		<p>REGOLATORE AUTOMATICO DI GIRI REGULATEUR AUTOM. DE VITESSE AUTOMATIC GOVERNOR</p>		
		<p>TAVOLA TABLE</p>	<p>4 34 1</p>	
		<p>FOGLIO FEUILLE PAGE</p>		
		<p>DATA DATE</p>	<p>2-73</p>	



270-4935-71
Ingranaggio

270-6371-81
Piastra

270-8400-56
Spina

270-7701-14
Rondella

1-1760-05
Bullone (6x1)

250-7555-03
Rondella 4

270-5202-89
Leva

270-9800-49
Vite (4 x 0.7)

270-8785-40
Supporto

500-6110-65
Perno 2

500-5496-30*
Massa 2

270-6130-36
Perno

270-4896-03
Gruppo mobile

250-1240-05
Anello Seeger

500-8805-10*
Supporto

260-1755-01
Bullone (5x0.8) 4

500-8805-13
SUPPORTO COMPL.

NOTE - REMARQUES - REMARKS
- Per gruppi elettrogeni.
- Pour groupes électrogènes.
- For generator sets.

* NON FORNITO SCIOLTO
NON LIVRE SEPARÉMENT
NOT SUPPLIED SEPARATELY

COMPLESSIVO - GROUPE - ASSEMBLY	270-7362-50	REGOLATORE DI GIRI DI PRECISIONE REGULATEUR DE VITESSE DE PRECISION PRECISION SPEED GOVERNOR	TAVOLA TABLE	4	34	2
MOTORE O VERSIONE MOTEUR OU ADAPTATION ENGINE OR VERSION	LDA96-97-100-820 (K.9983.73-9985.41)		FOGLIO FEUILLE PAGE			
			DATA DATE	2-73		

270-6230-24
Perno

270-5800-15
Molla

270-7625-02
Rondella LDA 96-97-LDAM 96.

270-7625-56
Rondella LDA 100-820.

200-2800-02
Copiglia

209-8420-12
Spina

270-6140-13
Perno

45-1755-04
Bullone (5x0.8)

238-1755-02
Bullone (5x0.8)

250-7555-03
Rondella 2

270-1557-21
Blocchetto

270-5655-05
Molla

270-4882-01
LEVA REGOLATORE E COMANDO PORTATA POMPA INIEZIONE COMPL. LDA 96.

280-4882-03
LEVA REGOLATORE E COMANDO PORTATA POMPA INIEZIONE COMPL. LDA 97-100.

291-5202-06
LEVA REGOLATORE E COMANDO PORTATA POMPA INIEZIONE COMPL. LDA 820.

270-5199-08
Leva LDA 96

280-5200-82
Leva LDA 97-100

291-5202-04
Leva LDA 820

260-1760-12
Bullone (6x1)

203-7540-04
Rondella

270-8615-20
Supporto

304-9800-13
Vite (6x1)

260-1165-06
Anello Benzing

270-3945-27
Forcella

NOTE - REMARQUES - REMARKS
* NON FORNITO SCIOLTO
NON LIVRE SEPARÉMENT
NOT SUPPLIED SEPARATELY

COMPLESSIVO - GROUPE - ASSEMBLY		LEVA REGOLATORE E COMANDO POMPA INIEZ. LEVIER REGULATEUR ET COMM. POMPE INJ. GOVERNOR AND INJ. PUMP CONTROL LEVER	TAVOLA TABLE	4	34	3
MOTORE O VERSIONE MOTEUR OU ADAPTATION ENGINE OR VERSION			FOGLIO FEUILLE PAGE			
			DATA DATE	2-73		



CATALOGO GENERALE RICAMBI

		NOTE - REMARQUES - REMARKS	
		-Fino a } LDA 96 N° 497643 -Jusqu'au } LDAM96 -Below } LDA 97 N° 505953	
<p>270-4535-09 * Guarnizione</p> <p>270-9800-09 Vite (6x1) 2</p> <p>270-5800-20 Molla</p> <p>406-1210-04 Anello tenuta</p> <p>270-6410-03 Piaffello</p>	<p>270-4840-04 Guida</p> <p>270-6410-03 Piaffello</p> <p>270-9520-06 Tubo</p> <p>47-1770-07 Bullone (8x1,25) 2</p> <p>270-4840-05 Guida</p> <p>270-4535-07 * Guarnizione</p>	* NON FORNITO SCIOLTO NON LIVRE SEPARÉMENT NOT SUPPLIED SEPARATELY	
COMPLESSIVO - GROUPE - ASSEMBLY		PROTEZIONE ASTE PUNTERIE PROTECTION TIGES POUSSOIRS TAPPET PUSH ROD TUBE	
MOTORE O VERSIONE MOTEUR OU ADAPTATION ENGINE OR VERSION	LDA96-97- LDAM 96	TAVOLA TABLE	4 35 1
		FOGLIO FEUILLE PAGE	
		DATA DATE	2-73

		NOTE - REMARQUES - REMARKS	
		-Da } LDA 96 N° 497644 -À partir de } LDAM96 -Starting from } LDA 97 N° 505954	
<p>70-4740-17 Guarnizione</p> <p>270-4840-08 Guida</p> <p>270-4535-13 * Guarnizione</p>	<p>270-9520-23 Tubo</p> <p>422-9730-28 Vite (8x1,25) 2</p> <p>1-7565-07 Rondella 2</p> <p>270-5168-05 Lamiera</p>	* NON FORNITO SCIOLTO NON LIVRE SEPARÉMENT NOT SUPPLIED SEPARATELY	
COMPLESSIVO - GROUPE - ASSEMBLY		PROTEZIONE ASTE PUNTERIE PROTECTION TIGES POUSSOIRS TAPPET PUSH ROD TUBE	
MOTORE O VERSIONE MOTEUR OU ADAPTATION ENGINE OR VERSION		TAVOLA TABLE	4 35 2
		FOGLIO FEUILLE PAGE	
		DATA DATE	2-73



CATALOGO GENERALE RICAMBI

270-4330-14 GRUPPO BILANCIERI COMPL. (b)

270-4330-17 GRUPPO BILANCIERI COMPL. (b) (c)

270-1540-60 BILANCIERE SCARICO COMPL. (b) (c)

270-1540-57 BILANCIERE SCARICO COMPL. (b)

* **270-1540-19** Bilanciere scarico

* **270-1540-44** Bilanciere scarico

270-9850-02 Vite 2

1-3240-10 Dado (7x1) 2

* **270-1540-14** Bilanciere aspiraz.

270-1540-56 BILANCIERE ASPIRAZ. COMPL. (b)

291-6045-29 Perno

70-9765-51 Vite

(a) **270-4330-01** GRUPPO BILANCIERI COMPL.

* **270-4560-04** Guarnizione

270-6045-02 Perno

202-1770-02 Bullone (8x1.25)

270-9800-17 Vite (8x1.25)

270-3800-12 Flangia

* **270-4500-52** Guarnizione

270-9800-17 Vite (8x1.25)

202-1770-02 Bullone (8x1.25)

70-1200-27 Anello OR

NOTE - REMARQUES - REMARKS

(a) -Fino a LDA 96
-Jusqu'au LDAM96 N° 497643
-Below LDA 97 N° 505953

(b) -Da LDA 96-LDAM96 N° 497644 fino a N° 761606.
-A partir de LDA 96-LDAM 96 N°497644 jusqu'au N° 761606
-Starting from LDA 96 - LDAM 96 N°497644 below N°761606.

-Fino a LDA 100 N° 733345
-Below

(c) -Solo decompressione e avviam. elettrico.
-Seulement décompres. et dém. électr.
-Only compress. release and el. start.

(d) -Da LDA 96-LDAM96 N° 497644
-Starting from LDA 97 N° 505953

* NON FORNITO SCIOLTO
NON LIVRE SEPARÉMENT
NOT SUPPLIED SEPARATELY

COMPLESSIVO - GROUPE - ASSEMBLY		TAVOLA TABLE	4	35	3
MOTORE O VERSIONE MOTEUR OU ADAPTATION ENGINE OR VERSION	LDA 96-97-100-LDAM96	FOGLIO FEUILLE PAGE			
		DATA DATE	2 - 73		

**GRUPPO BILANCIERI
GROUPE CULBUTEURS
ROCKER ARM ASSEMBLY**

270-9850-02 Vite 2

1-3240-10 Dado (7x1) 2

70-1200-27 Anello OR

* **291-1540-80** Bilanciere aspiraz.

291-1540-83 BILANCIERE ASPIRAZ. COMPL.

291-1540-84 BILANCIERE SCARICO COMPL.

291-1540-90 Bilanciere scarico *

70-9765-51 Vite

291-6045-29 Perno

NOTE - REMARQUES - REMARKS

-Da LDA 96 N° 761607
-A partir de LDAM96 N° 779626
-Starting from LDA 100 N° 789946

* NON FORNITO SCIOLTO
NON LIVRE SEPARÉMENT
NOT SUPPLIED SEPARATELY

COMPLESSIVO - GROUPE - ASSEMBLY	291-4330-23	TAVOLA TABLE	4	35	4
MOTORE O VERSIONE MOTEUR OU ADAPTATION ENGINE OR VERSION		FOGLIO FEUILLE PAGE			
		DATA DATE	2 - 73		

**GRUPPO BILANCIERI
GROUPE CULBUTEURS
ROCKER ARM ASSEMBLY**



406-7770-58
Rullo

270-6045-06

6045-07

6045-08

260-9730-27
Vite (8x1,25) 2

260-9730-25
Vite (8x1,25)

209-1770-15
Bullone (8x1,25)

1-7565-07
Rondella

312-1240-43
Anello Seeger

270-4330-02
BILANCIERE COMPL.

271-6045-09
Perno

270-6110-53
Perno

270-6110-40
Perno

270-6110-48
Perno

270-6110-39
Perno

270-6110-55
Perno

270-6110-57
Perno

270-6110-68
Perno

270-6110-52
Perno

270-6110-38
Perno

270-6110-49
Perno

270-6110-37
Perno

270-6110-54
Perno

270-6110-56
Perno

283-6110-58
Perno

283-6110-59
Perno

NOTE - REMARQUES - REMARKS

(a) -Fino a } LDA 96 N° 497643
-Jusqu'au } LDAM96 N° 497644
-Below } LDA 97 N° 505953

(b) -Da } LDA 96 N° 497644
-A partir de } LDAM96 N° 497644
-Starting from } LDA 97 N° 505954

△ -Perni scenterati a destra.
-Axes excentriques droites.
-Off-center journals(right).

(c) 0.20 (d) 0.35
(e) 0.50 (f) 0.70
(g) 1 (h) 1.50
(i) 2

□ -Perni scenterati a sinistra.
-Axes excentriques gauches.
-Off-center journals(left).

(l) 0.20 (m) 0.35
(n) 0.50 (o) 0.70
(p) 1 (q) 1.50
(r) 2 (s) 2.50

* NON FORNITO SCIOLTO
NON LIVRE SEPAREMENT
NOT SUPPLIED SEPARATELY

COMPLESSIVO - GROUPE - ASSEMBLY		BILANCIERE COMANDO POMPA INIEZIONE CULBUTEUR COMMANDE POMPE INJECTION INJECTION PUMP ROCKER ARM	TAVOLA TABLE	4	35	5
MOTORE O VERSIONE MOTEUR OU ADAPTATION ENGINE OR VERSION			FOGLIO FEUILLE PAGE			
			DATA DATE	2-73		

270-8576-01
SUPPLEMENTO COMBUSTIBILE
E STOP COMPL.

* **270-8615-23**
Supporto

270-5420-08
Maniglia

270-8420-01
Spina

270-4775-37
Guarnizione

1-1760-05
Bullone (6x1) 2

270-4700-70
Guarnizione 0.50*

270-4700-71
Guarnizione 1*

270-2015-22
Camma con albero

270-5550-07
Molla

70-7625-62
Rondella 2

NOTE - REMARQUES - REMARKS

* NON FORNITO SCIOLTO
NON LIVRE SEPAREMENT
NOT SUPPLIED SEPARATELY

COMPLESSIVO - GROUPE - ASSEMBLY		SUPPLEMENTO COMBUSTIBILE E STOP SUPPLEMENT COMBUSTIBLE E STOP EXTRA FUEL AND STOP DEVICE	TAVOLA TABLE	4	36	1
MOTORE O VERSIONE MOTEUR OU ADAPTATION ENGINE OR VERSION			FOGLIO FEUILLE PAGE			
			DATA DATE	2-73		



CATALOGO GENERALE RICAMBI

NOTE - REMARQUES - REMARKS

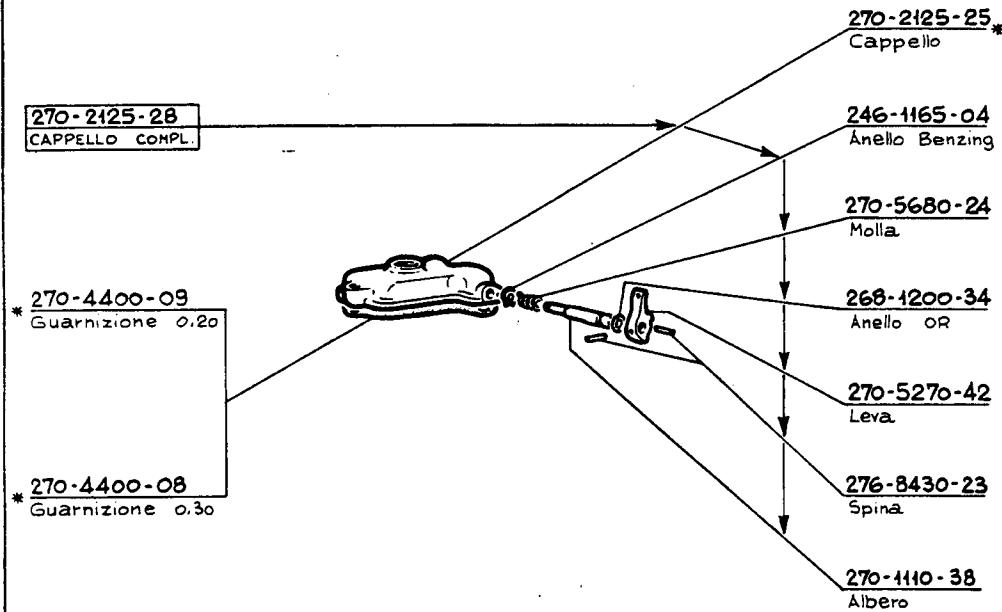

* NON FORNITO SCIOLTO
NON LIVRE SEPARÉMENT
NOT SUPPLIED SEPARATELY

COMPLESSIVO - GROUPE - ASSEMBLY

MOTORE O VERSIONE
MOTEUR OU ADAPTATION
ENGINE OR VERSION

(K. 9981.16)

CAPPELLO BILANCIERI PER DECOMPRESSIONE
COUVERCLE CULBUTEUR POUR DECOMPRESS.
ROCKER ARM COVER FOR COMPRESS.RELEASE

TAVOLA TABLE	4	37	1
FOGLIO FEUILLE PAGE			
DATA DATE	2-73		

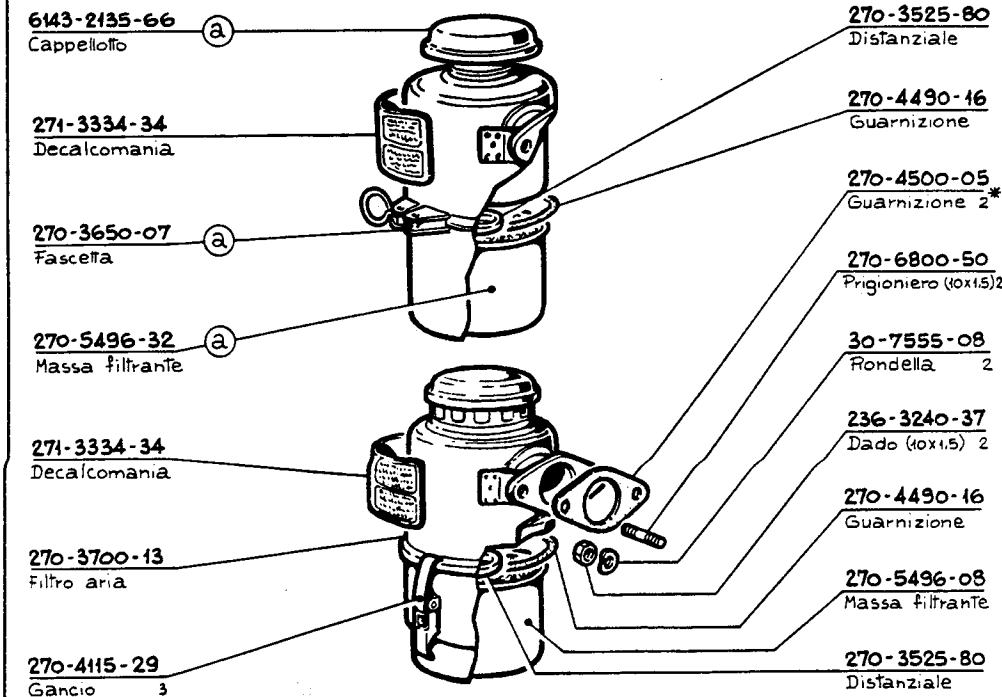

NOTE - REMARQUES - REMARKS

(a) - Solo per filtri FISPA.
- Seulement pour filtres FISPA.
- Only for FISPA filters.

* NON FORNITO SCIOLTO
NON LIVRE SEPARÉMENT
NOT SUPPLIED SEPARATELY

COMPLESSIVO - GROUPE - ASSEMBLY

MOTORE O VERSIONE
MOTEUR OU ADAPTATION
ENGINE OR VERSION

LDA96-97-100
(K. 9964.00)

FILTRO ARIA STANDARD
FILTRE A AIR STANDARD
STANDARD AIR CLEANER

TAVOLA TABLE	4	41	1
FOGLIO FEUILLE PAGE			
DATA DATE	2-73		



CATALOGO GENERALE RICAMBI

<p>291-3702-03 FILTRO ARIA COMPL.</p>		<p>270-4500-05 Guarnizione 2 *</p>		<p>NOTE - REMARQUES - REMARKS</p>				
<p>6143-2135-66 Cappello</p>		<p>270-6800-50 Prigioniero (10x1,5) 2</p>						
<p>271-3334-34 Decalcomania</p>		<p>30-7555-08 Rondella 2</p>						
<p>291-3701-35 * Filtro aria</p>		<p>236-3240-37 Dado (10x1,5) 2</p>						
<p>270-4115-29 Gancio 3</p>		<p>270-4490-16 Guarnizione</p>						
		<p>291-5496-19 Massa filtrante</p>						
		<p>270-3525-80 Distanziale</p>						
<p>* NON FORNITO SCIOLTO NON LIVRE SEPAREMENT NOT SUPPLIED SEPARATELY</p>								
<p>COMPLESSIVO - GROUPE - ASSEMBLY</p>		<p>FILTRO ARIA STANDARD FILTRE A AIR STANDARD STANDARD AIR CLEANER</p>			<p>TAVOLA TABLE</p> <table border="1"> <tr> <td>4</td> <td>41</td> <td>2</td> </tr> </table>	4	41	2
4	41	2						
<p>MOTORE O VERSIONE MOTEUR OU ADAPTATION ENGINE OR VERSION</p>	<p>LDA 820 (K. 9964.48)</p>			<p>FOGLIO FEUILLE PAGE</p>				
				<p>DATA DATE</p> <p>2-73</p>				

<p>266-6727-01 Prefiltro</p>		<p>270-6800-50 Prigioniero (10x1,5) 2</p>		<p>NOTE - REMARQUES - REMARKS</p> <p>-Vedi anche Tav. } -Voir aussi Table } 4-71-1 -See also Table }</p>				
<p>8068-2940-58 Curva aspiraz.</p>		<p>30-7555-08 Rondella 2</p>						
<p>270-4500-05 * Guarnizione 2</p>		<p>236-3240-37 Dado (10x1,5) 2</p>						
<p>* NON FORNITO SCIOLTO NON LIVRE SEPAREMENT NOT SUPPLIED SEPARATELY</p>								
<p>COMPLESSIVO - GROUPE - ASSEMBLY</p>		<p>FILTRO ARIA VERSIONE MARINA FILTRE A AIR VERSION MARINE MARINE VERSION AIR CLEANER</p>			<p>TAVOLA TABLE</p> <table border="1"> <tr> <td>4</td> <td>41</td> <td>3</td> </tr> </table>	4	41	3
4	41	3						
<p>MOTORE O VERSIONE MOTEUR OU ADAPTATION ENGINE OR VERSION</p>	<p>LDAM 96 (K. 9964.06)</p>				<p>FOGLIO FEUILLE PAGE</p>			
					<p>DATA DATE</p> <p>2-73</p>			



CATALOGO GENERALE RICAMBI

<p>270-3700-70 Filtro aria</p>		<p>270-4500-05* Guarnizione 2</p>		<p>NOTE - REMARQUES - REMARKS</p> <p>-Per motore con pompa oleodinamica. -Pour moteur avec pompe hydraulique. -For engine with hydraulic pump.</p>
<p>271-3334-34 Decalcomania</p>		<p>270-6800-50 Prigioniero (10x1,5) 2</p>		
<p>270-4115-29 Gancio 3</p>		<p>30-7555-08 Rondella 2</p>		
<p>270-5496-08 Massa filtrante</p>		<p>236-3240-37 Dado (10x1,5) 2</p>		
		<p>270-4490-16 Guarnizione</p>		
		<p>270-3525-80 Distanziale</p>		
		<p>* NON FORNITO SCOLTO NON LIVRE SEPARÉMENT NOT SUPPLIED SEPARATELY</p>		
<p>COMPLESSIVO - GROUPE - ASSEMBLY</p>		<p>FILTRO ARIA FILTRE A AIR AIR CLEANER</p>		<p>TAVOLA TABLE 4 41 4</p> <p>FOGLIO FEUILLE</p> <p>PAGE</p> <p>DATA DATE 2-73</p>
<p>MOTORE O VERSIONE MOTEUR OU ADAPTATION ENGINE OR VERSION</p>	<p>LDA 96-97-100 (K.9964.05)</p>			

<p>291-3702-03 FILTRO ARIA COMPL.</p>		<p>999-1780-31 Bullone (10x1,5) 2</p>		<p>NOTE - REMARQUES - REMARKS</p> <p>-Per motore con comando stop e suppl. combust. a distanza. -Pour moteur avec comm. stop et suppl. combust. a distance. -For engines with remote stop and extra fuel control.</p>
<p>6143-2135-66 Cappellofio</p>		<p>30-7555-08 Rondella 2</p>		
<p>271-3334-34 Decalcomania</p>		<p>3-3240-33 Dado (10x1,5) 2</p>		
<p>* 291-3701-35 Filtro aria</p>		<p>270-4500-05* Guarnizione 3</p>		
<p>270-4115-29 Gancio 3</p>		<p>270-6800-50 Prigioniero (10x1,5) 2</p>		
<p>291-5496-19 Massa filtrante</p>		<p>30-7555-08 Rondella 2</p>		
		<p>236-3240-37 Dado (10x1,5) 2</p>		
		<p>6182-6901-20 Prolunga</p>		
		<p>270-4490-16 Guarnizione</p>		
		<p>270-3525-80 Distanziale</p>		
		<p>* NON FORNITO SCOLTO NON LIVRE SEPARÉMENT NOT SUPPLIED SEPARATELY</p>		
<p>COMPLESSIVO - GROUPE - ASSEMBLY</p>		<p>FILTRO ARIA FILTRE A AIR AIR CLEANER</p>		<p>TAVOLA TABLE 4 41 5</p> <p>FOGLIO FEUILLE</p> <p>PAGE</p> <p>DATA DATE 2-73</p>
<p>MOTORE O VERSIONE MOTEUR OU ADAPTATION ENGINE OR VERSION</p>	<p>LDA 820 (K.9964.52)</p>			



		NOTE - REMARQUES - REMARKS	
		-In ambiente polveroso. -Dans une atmosphère poussiéreuse. -Under dusty conditions.	
270-3702-09 FILTRO ARIA COMPL.		270-4500-05* Guarnizione 2	
6184-6727-03 Prefiltro		270-6800-50 Prigioniero (40x1,5) 2	
271-3334-34 Decalcomania		30-7555-08 Rondella 2	
* 270-3701-07 Filtro aria		236-3240-37 Dado (40x1,5) 2	
270-4115-29 Gancio 3		270-4490-16 Guarnizione	
		270-5496-08 Massa filtrante	
		270-3525-80 Distanziale	
		* NON FORNITO SCIOLTO NON LIVRE SEPARÉMENT NOT SUPPLIED SEPARATELY	
COMPLESSIVO - GROUPE - ASSEMBLY		TAVOLA TABLE 4 41 6	
MOTORE O VERSIONE MOTEUR OU ADAPTATION ENGINE OR VERSION		FILTRO ARIA PREDISP. PREFILTRO A CICLONE FILTRE A AIR ADAPT. POUR PREFILTRE CYCL. AIR CLEANER SUITABLE FOR CYCL. PREFILTER	
LDA96-97-100 (K.9964.40)		FOGLIO FEUILLE PAGE DATA DATE 2-73	

		NOTE - REMARQUES - REMARKS	
		-Per motore con pompa oleodinamica. -Pour moteur avec pompe hydraulique. -For engine with hydraulic pump. -In ambiente polveroso. -Dans une atmosphère poussiéreuse. -Under dusty conditions.	
8060-3700-97 FILTRO ARIA COMPL.		270-4500-05* Guarnizione 2	
6184-6727-03 Prefiltro		270-6800-50 Prigioniero (40x1,5) 2	
271-3334-34 Decalcomania		30-7555-08 Rondella 2	
* 8060-3700-98 Filtro aria		236-3240-37 Dado (40x1,5) 2	
270-4115-29 Gancio 3		270-4490-16 Guarnizione	
		270-5496-08 Massa filtrante	
		270-3525-80 Distanziale	
		* NON FORNITO SCIOLTO NON LIVRE SEPARÉMENT NOT SUPPLIED SEPARATELY	
COMPLESSIVO - GROUPE - ASSEMBLY		TAVOLA TABLE 4 41 7	
MOTORE O VERSIONE MOTEUR OU ADAPTATION ENGINE OR VERSION		FILTRO ARIA PREDISP. PREFILTRO A CICLONE FILTRE A AIR ADAPT. POUR PREFILTRE CYCL. AIR CLEANER SUITABLE FOR CYCL. PREFILTER	
LDA96-97-100 (K.9964.36)		FOGLIO FEUILLE PAGE DATA DATE 2-73	



CATALOGO GENERALE RICAMBI

<p>6183-3702-12 FILTRO ARIA COMPL.</p>			<p>270-4500-05* Guarnizione 2</p>		<p>NOTE - REMARQUES - REMARKS</p> <p>-In ambiente polveroso. -Dans une atmosphère poussiéreuse. -Under dusty conditions.</p>
<p>6184-6727-03 Prefiltro</p>			<p>270-6800-50 Prigioniero (10x1,5) 2</p>		
<p>271-3334-34 Decalcomania</p>			<p>30-7555-08 Rondella 2</p>		
<p>6183-3701-37* Filtro aria</p>			<p>236-3240-37 Dado (10x1,5) 2</p>		
<p>270-4115-29 Gancio 3</p>			<p>270-4490-16 Guarnizione</p>		
			<p>291-5496-19 Massa filtrante</p>		
		<p>270-3525-80 Distanziale</p>		<p>* NON FORNITO SCIOLTO NON LIVRE SEPARÉMENT NOT SUPPLIED SEPARATELY</p>	
<p>COMPLESSIVO - GROUPE - ASSEMBLY</p>		<p>FILTRO ARIA PREDISP. PREFILTRO A CICLONE FILTRE A AIR ADAPT. POUR PREFILTRE CYCL. AIR CLEANER SUITABLE FOR CYCL. PREFILTER</p>		<p>TAVOLA TABLE</p>	<p>4 41 8</p>
<p>MOTORE O VERSIONE MOTEUR OU ADAPTATION ENGINE OR VERSION</p>	<p>LDA 820 (K.9964.57)</p>			<p>FOGLIO FEUILLE PAGE</p>	
				<p>DATA DATE</p>	<p>2-73</p>

<p>291-3702-10 FILTRO ARIA COMPL.</p>			<p>270-4500-05* Guarnizione 2</p>		<p>NOTE - REMARQUES - REMARKS</p> <p>-Per motore con pompa oleodinamica. -Pour moteur avec pompe hydraulique. -For engine with hydraulic pump.</p> <p>-In ambiente polveroso. -Dans une atmosphère poussiéreuse. -Under dusty conditions.</p>
<p>6184-6727-03 Prefiltro</p>			<p>270-6800-50 Prigioniero (10x1,5) 2</p>		
<p>271-3334-34 Decalcomania</p>			<p>30-7555-08 Rondella 2</p>		
<p>231-3701-35* Filtro aria</p>			<p>236-3240-37 Dado (10x1,5) 2</p>		
<p>270-4115-29 Gancio 3</p>			<p>270-4490-16 Guarnizione</p>		
			<p>291-5496-19 Massa filtrante</p>		
		<p>270-3525-80 Distanziale</p>		<p>* NON FORNITO SCIOLTO NON LIVRE SEPARÉMENT NOT SUPPLIED SEPARATELY</p>	
<p>COMPLESSIVO - GROUPE - ASSEMBLY</p>		<p>FILTRO ARIA PREDISP. PREFILTRO A CICLONE FILTRE A AIR ADAPT. POUR PREFILTRE CYCL. AIR CLEANER SUITABLE FOR CYCL. PREFILTER</p>		<p>TAVOLA TABLE</p>	<p>4 41 9</p>
<p>MOTORE O VERSIONE MOTEUR OU ADAPTATION ENGINE OR VERSION</p>	<p>LDA 820 (K.9964.56)</p>			<p>FOGLIO FEUILLE PAGE</p>	
				<p>DATA DATE</p>	<p>2-73</p>

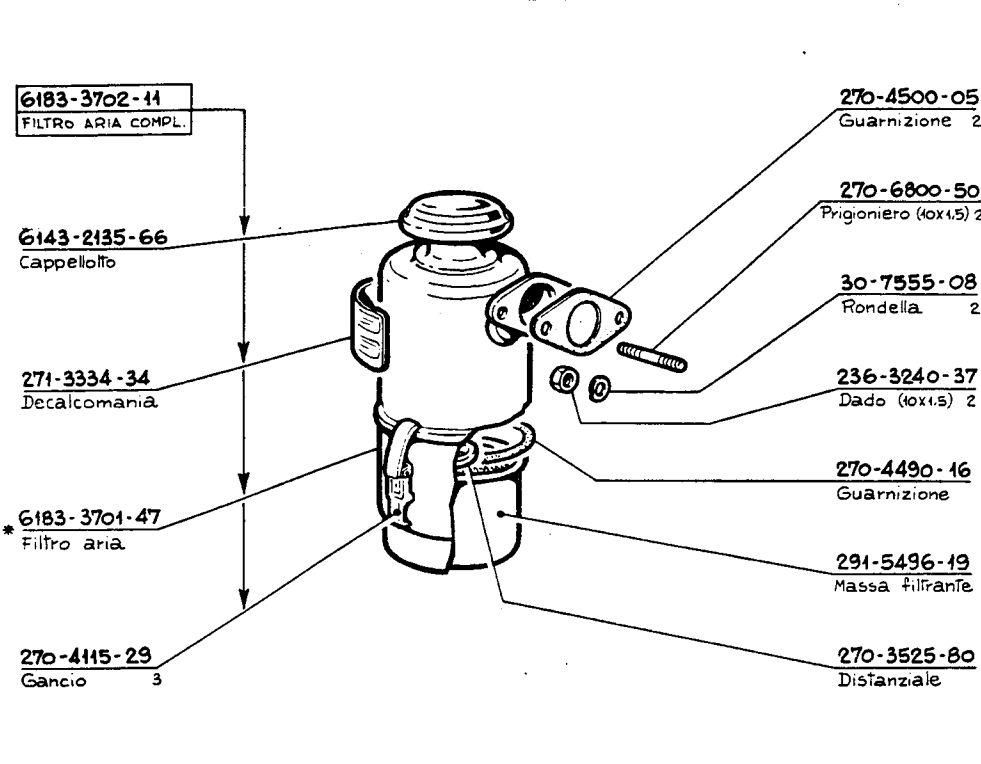

		<p>NOTE - REMARQUES - REMARKS</p>												
<p>COMPLESSIVO - GROUPE - ASSEMBLY</p>		<p>* NON FORNITO SCIOLTO NON LIVRE SEPARÉMENT NOT SUPPLIED SEPARATELY</p>												
<p>MOTORE O VERSIONE MOTEUR OU ADAPTATION ENGINE OR VERSION</p>	<p>LDA 820 (K.9964.58)</p>	<p>FILTRO ARIA ABBASSATO FILTRE A AIR BAS LOW POSITION AIR CLEANER</p>												
		<table border="1"> <tr> <td>TAVOLA TABLE</td> <td>4</td> <td>41</td> <td>10</td> </tr> <tr> <td>FOGLIO FEUILLE PAGE</td> <td></td> <td></td> <td></td> </tr> <tr> <td>DATA DATE</td> <td colspan="3">2-73</td> </tr> </table>	TAVOLA TABLE	4	41	10	FOGLIO FEUILLE PAGE				DATA DATE	2-73		
TAVOLA TABLE	4	41	10											
FOGLIO FEUILLE PAGE														
DATA DATE	2-73													

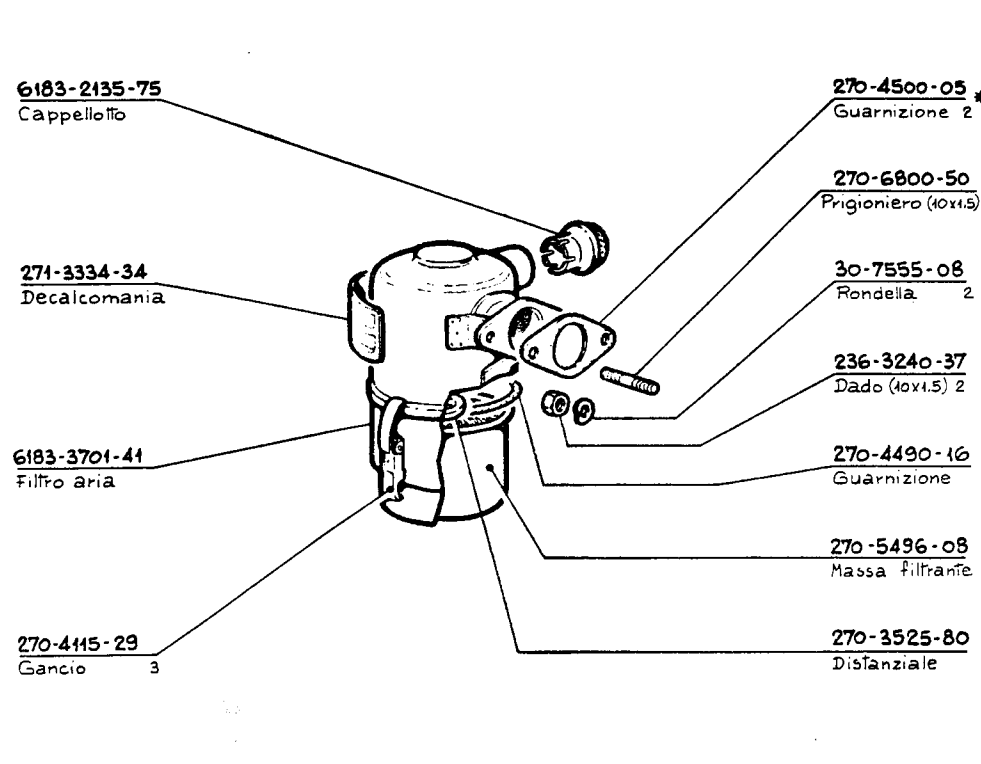
		<p>NOTE - REMARQUES - REMARKS</p> <p>-Con presa aria laterale. -Avec prise d'air laterale. -With side air inlet.</p>												
<p>COMPLESSIVO - GROUPE - ASSEMBLY</p>		<p>* NON FORNITO SCIOLTO NON LIVRE SEPARÉMENT NOT SUPPLIED SEPARATELY</p>												
<p>MOTORE O VERSIONE MOTEUR OU ADAPTATION ENGINE OR VERSION</p>	<p>LDA96-97-100 (K.9964.39)</p>	<p>FILTRO ARIA ABBASSATO FILTRE A AIR BAS LOW POSITION AIR CLEANER</p>												
		<table border="1"> <tr> <td>TAVOLA TABLE</td> <td>4</td> <td>41</td> <td>11</td> </tr> <tr> <td>FOGLIO FEUILLE PAGE</td> <td></td> <td></td> <td></td> </tr> <tr> <td>DATA DATE</td> <td colspan="3">2-73</td> </tr> </table>	TAVOLA TABLE	4	41	11	FOGLIO FEUILLE PAGE				DATA DATE	2-73		
TAVOLA TABLE	4	41	11											
FOGLIO FEUILLE PAGE														
DATA DATE	2-73													



NOTE - REMARQUES - REMARKS

-Con presa aria laterale.
-Avec prise d'air latérale.
-With side air inlet.

6183-2135-75
Cappelloffo

270-4500-05
Guarnizione 2*

271-3334-34
Decalcomania

270-6800-50
Prigioniero (10x1,5) 2

6183-3701-36
Filtro aria

30-7555-08
Rondella 2

236-3240-37
Dado (10x1,5) 2

270-4115-29
Gancio 3

270-4490-16
Guarnizione

291-5496-19
Massa filtrante

270-3525-80
Distanziale

* NON FORNITO SCIOLTO
NON LIVRE SEPARÉMENT
NOT SUPPLIED SEPARATELY

COMPLESSIVO - GROUPE - ASSEMBLY

MOTORE O VERSIONE
MOTEUR OU ADAPTATION
ENGINE OR VERSION

LDA 820
(K.9964.53)

FILTRO ARIA ABBASSATO
FILTRE A AIR BAS
LOW POSITION AIR CLEANER

TAVOLA TABLE	4	41	12
FOGLIO FEUILLE PAGE			
DATA DATE	2-73		

9345-33
Tubo 2

260-3630-21
Fascetta 4

NOTE - REMARQUES - REMARKS

-In ambiente polveroso.
-Dans une atmosphère poussiéreuse.
-Under dusty conditions.

-Fornito staccato.
-Livré séparé.
-Separately supplied.

6143-2135-66
Cappelloffo

263-9425-05
Tubo

271-3334-34
Decalcomania

30-7555-08
Rondella 2

3700-17
Filtro aria

236-3240-37
Dado (10x1,5) 2

270-4115-29
Gancio 3

3780-41
Flangia

8330-05
Spessore

270-4500-05
Guarnizione 2*

8740-17
Supporto

270-6800-50
Prigioniero (10x1,5) 2

* 261-3615-26
Fascetta

261-3615-80
FASCETTA COMPL.

260-9730-36
Vite (8x1,25)

254-1557-07
Blocchetto

254-1557-18
Blocchetto

* NON FORNITO SCIOLTO
NON LIVRE SEPARÉMENT
NOT SUPPLIED SEPARATELY

COMPLESSIVO - GROUPE - ASSEMBLY

MOTORE O VERSIONE
MOTEUR OU ADAPTATION
ENGINE OR VERSION

LDA 96-97-100
(K.9964.01)

FILTRO ARIA
FILTRE A AIR
AIR CLEANER

TAVOLA TABLE	4	41	13
FOGLIO FEUILLE PAGE			
DATA DATE	2-73		



9345-33
Tubo 2

6184-6727-03
Prefiltro

271-3334-34
Decalcomania

8060-3700-96
Filtro aria

270-4115-29
Gancio 3

8330-05
Spessore

8740-17
Supporto

261-3615-26
* Fascetta

260-3630-21
Fascetta 4

263-9425-05
Tubo

30-7555-08
Rondella 2

236-3240-37
Dado (10x1,5) 2

3780-41
Fiangia

270-4500-05*
Guarnizione 2

270-6800-50
Prigioniero (10x1,5) 2

264-3615-80
FASCETTA COMPL.

260-9730-36
Vite (8x1,25)

254-1557-07
Blocchetto

254-1557-18
Blocchetto

NOTE - REMARQUES - REMARKS

-In ambiente polveroso.
-Dans une atmosphère poussiéreuse.
-Under dusty conditions.

-Fornito staccato.
-Livré séparé
-Separately supplied.

* NON FORNITO SCIOLTO
NON LIVRE SEPARÉMENT
NOT SUPPLIED SEPARATELY

COMPLESSIVO - GROUPE - ASSEMBLY		TAVOLA TABLE	4	41	14
MOTORE O VERSIONE MOTEUR OU ADAPTATION ENGINE OR VERSION	LDA 96-97-100 (K.9964.32)	FILTRO ARIA PREDIS. PREFILTRO A CICLONE FILTRE A AIR ADAPT. POUR PREFILTRE CYCL. AIR CLEANER SUITABLE FOR CYCL. PREFILTER	FOGLIO FEUILLE PAGE		
		DATA DATE	2-73		

6183-3702-40

6184-9345-79
Tubo

270-6800-50
Prigioniero (10x1,5) 2

3630-24
Fascetta 2

270-4500-05*
Guarnizione 2

6183-3701-41
Filtro aria

271-3334-34
Decalcomania

270-4115-29
Gancio 3

270-3525-80
Distanziale

270-5496-08
Massa filtrante

1002-9731-23
Vite (12x1,5) 3

205-7625-26
Rondella 3

6184-6727-03
Prefiltro

6184-8901-71
Supporto

8021-3206-20
Dado 2

8021-3206-19
Dado 2

30-7555-08
Rondella 2

236-3240-37
Dado (10x1,5) 2

270-4490-16
Guarnizione

NOTE - REMARQUES - REMARKS

-In ambiente polveroso.
-Dans une atmosphère poussiéreuse.
-Under dusty conditions.

-Con presa aria laterale.
-Avec prise d'air latérale.
-With side air inlet.

* NON FORNITO SCIOLTO
NON LIVRE SEPARÉMENT
NOT SUPPLIED SEPARATELY

COMPLESSIVO - GROUPE - ASSEMBLY		TAVOLA TABLE	4	41	15
MOTORE O VERSIONE MOTEUR OU ADAPTATION ENGINE OR VERSION	LDA 96-97-100 (K.9964.45)	FILTRO ARIA FILTRE A AIR AIR CLEANER	FOGLIO FEUILLE PAGE		
		DATA DATE	2-73		



CATALOGO GENERALE RICAMBI

6184-9345-79
Tubo

270-6800-50
Prigioniero (10x1,5) 2

3630-24
Fascetta 2

270-4500-05
Guarnizione 2

6183-3701-36
Filtro aria

271-3334-34
Decalcomania

270-4115-29
Gancio 3

270-3525-80
Distanziale

291-5496-19
Massa filtrante

1002-9731-23
Vite (12x1,5) 3

205-7625-26
Rondella 3

6184-6727-03
Prefiltro

6184-8901-71
Supporto

8021-3206-20
Dado 2

8021-3206-19
Dado 2

30-7555-08
Rondella 2

236-3240-37
Dado (10x1,5) 2

270-4490-16
Guarnizione

NOTE - REMARQUES - REMARKS

-In ambiente polveroso.
-Dans une atmosphère poussiéreuse.
-Under dusty conditions.

-Con presa aria laterale.
-Avec prise d'air latérale.
-With side air inlet.

* NON FORNITO SCOLTO
NON LIVRE SEPARÉMENT
NOT SUPPLIED SEPARATELY

COMPLESSIVO - GROUPE - ASSEMBLY			TAVOLA TABLE	4	41	16
MOTORE O VERSIONE MOTEUR OU ADAPTATION ENGINE OR VERSION	LDA 820 (K.9964.55)	FILTRO ARIA FILTRE A AIR AIR CLEANER	FOGLIO FEUILLE PAGE			
			DATA DATE	2-73		

270-6800-50
Prigioniero (10x1,5) 2

30-7555-08
Rondella 2

270-3240-53
Dado (10x1,5) 2

270-4775-39
Guarnizione 2

270-5460-90
Marmitta scarico

NOTE - REMARQUES - REMARKS

* NON FORNITO SCOLTO
NON LIVRE SEPARÉMENT
NOT SUPPLIED SEPARATELY

COMPLESSIVO - GROUPE - ASSEMBLY			TAVOLA TABLE	4	42	1
MOTORE O VERSIONE MOTEUR OU ADAPTATION ENGINE OR VERSION	LDA 96-97 (K.9962.18)	MARMITTA SCARICO STANDARD POT D'ÉCHAPPEMENT STANDARD STANDARD EXHAUST MUFFLER	FOGLIO FEUILLE PAGE			
			DATA DATE	2-73		



		<p style="text-align: center; font-size: small;">NOTE - REMARQUES - REMARKS</p>												
<p>270-6800-50 Prigioniero (10x1,5) 2</p> <p>30-7555-08 Rondella 2</p> <p>270-3240-53 Dado (10x1,5) 2</p>	<p>270-4775-39 Guarnizione 2</p> <p>279-5461-48 Marmitta scarico</p>													
<p>COMPLESSIVO - GROUPE - ASSEMBLY</p>		<p>* NON FORNITO SCOLTO NON LIVRE SEPAREMENT NOT SUPPLIED SEPARATELY</p>												
<p>MOTORE O VERSIONE MOTEUR OU ADAPTATION ENGINE OR VERSION</p>	<p>LDA 100 (K.9962.65)</p>	<p style="text-align: center;">MARMITTA SCARICO STANDARD POT D'ÉCHAPPEMENT STANDARD STANDARD EXHAUST MUEFLER</p>												
		<table border="1" style="font-size: x-small; border-collapse: collapse;"> <tr> <td style="padding: 2px;">TAVOLA TABLE</td> <td style="text-align: center; padding: 2px;">4</td> <td style="text-align: center; padding: 2px;">42</td> <td style="text-align: center; padding: 2px;">2</td> </tr> <tr> <td style="padding: 2px;">FOGLIO FEUILLE PAGE</td> <td></td> <td></td> <td></td> </tr> <tr> <td style="padding: 2px;">DATA DATE</td> <td colspan="3" style="text-align: center; padding: 2px;">2-73</td> </tr> </table>	TAVOLA TABLE	4	42	2	FOGLIO FEUILLE PAGE				DATA DATE	2-73		
TAVOLA TABLE	4	42	2											
FOGLIO FEUILLE PAGE														
DATA DATE	2-73													

		<p style="text-align: center; font-size: small;">NOTE - REMARQUES - REMARKS</p>												
<p>270-4775-39 Guarnizione 2</p> <p>270-6800-50 Prigioniero (10x1,5) 2</p> <p>30-7555-08 Rondella 2</p> <p>270-3240-53 Dado (10x1,5) 2</p> <p>6493-2941-02 Curva scarico</p> <p>276-4500-79 Guarnizione</p> <p>6493-5461-47 Marmitta scarico</p> <p>6221-1780-33 Bullone (10x1,5)</p>	<p>1-1770-06 Bullone (8x1,25) 2</p> <p>1-7565-07 Rondella 2</p> <p>3-3240-19 Dado (8x1,25) 2</p> <p>291-9170-20 Terminale</p> <p>6493-8545-40 Staffa</p> <p>202-7565-41 Rondella</p> <p>260-3240-31 Dado (10x1,5)</p> <p>202-7565-41 Rondella 2</p> <p>26-1780-07 Bullone (10x1,5) 2</p>	<p>-Moteur con piedi. -Moteur avec pieds. -Engine with mounts.</p>												
<p>COMPLESSIVO - GROUPE - ASSEMBLY</p>		<p>* NON FORNITO SCOLTO NON LIVRE SEPAREMENT NOT SUPPLIED SEPARATELY</p>												
<p>MOTORE O VERSIONE MOTEUR OU ADAPTATION ENGINE OR VERSION</p>	<p>LDA 820 (K.9962.80)</p>	<p style="text-align: center;">MARMITTA SCARICO SILENZIATRICE VERTICALE POT D'ÉCHAPPEMENT SILENCIEUX VERTICAL VERTICAL EXHAUST SILENCER</p>												
		<table border="1" style="font-size: x-small; border-collapse: collapse;"> <tr> <td style="padding: 2px;">TAVOLA TABLE</td> <td style="text-align: center; padding: 2px;">4</td> <td style="text-align: center; padding: 2px;">42</td> <td style="text-align: center; padding: 2px;">3</td> </tr> <tr> <td style="padding: 2px;">FOGLIO FEUILLE PAGE</td> <td></td> <td></td> <td></td> </tr> <tr> <td style="padding: 2px;">DATA DATE</td> <td colspan="3" style="text-align: center; padding: 2px;">2-73</td> </tr> </table>	TAVOLA TABLE	4	42	3	FOGLIO FEUILLE PAGE				DATA DATE	2-73		
TAVOLA TABLE	4	42	3											
FOGLIO FEUILLE PAGE														
DATA DATE	2-73													



CATALOGO GENERALE RICAMBI

NOTE - REMARQUES - REMARKS

- Motore senza piedi.
- Moteur sans pieds.
- Engine without mounts.

* NON FORNITO SCIOLTO
NON LIVRE SEPAREMENT
NOT SUPPLIED SEPARATELY

COMPLESSIVO - GROUPE - ASSEMBLY		MARMITTA SCARICO SILENZIATRICE VERTICALE POT D'ÉCHAPPEMENT SILENCIEUX VERTICAL VERTICAL EXHAUST SILENCER	TAVOLA TABLE	4	42	4
MOTORE O VERSIONE MOTEUR OU ADAPTATION ENGINE OR VERSION	LDA 820 (K.9962.66)		FOGLIO FEUILLE PAGE			
			DATA DATE	2 - 73		

Part List:

- 270-4775-39 Guarnizione 2
- 270-6800-50 Prigioniero (10x1.5) 2
- 30-7555-08 Rondella 2
- 270-3240-53 Dado (10x1.5) 2
- 6493-2941-02 Curva scarico
- 276-4500-79 Guarnizione
- 6493-5461-47 Marmitta scarico
- 6221-1780-33 Bullone (10x1.5)
- 6493-8335-53 Spessore
- 1-1770-06 Bullone (8x1.25) 2
- 1-7565-07 Rondella 2
- 3-3240-19 Dado (8x1.25) 2
- 291-9170-28 Terminale
- 6493-8545-40 Staffa
- 202-7565-11 Rondella
- 260-3240-31 Dado (10x1.5)
- 202-7565-11 Rondella 2
- 26-1780-07 Bullone (10x1.5) 2

NOTE - REMARQUES - REMARKS

- Motore con piedi elastici.
- Moteur avec pieds elastiques.
- Engine with soft mounts.

* NON FORNITO SCIOLTO
NON LIVRE SEPAREMENT
NOT SUPPLIED SEPARATELY

COMPLESSIVO - GROUPE - ASSEMBLY		MARMITTA SCARICO SILENZIATRICE VERTICALE POT D'ÉCHAPPEMENT SILENCIEUX VERTICAL VERTICAL EXHAUST SILENCER	TAVOLA TABLE	4	42	5
MOTORE O VERSIONE MOTEUR OU ADAPTATION ENGINE OR VERSION	LDA 820 (K.9962.84)		FOGLIO FEUILLE PAGE			
			DATA DATE	2 - 73		

Part List:

- 270-4775-39 Guarnizione 2
- 270-6800-50 Prigioniero (10x1.5) 2
- 30-7555-08 Rondella 2
- 270-3240-53 Dado (10x1.5) 2
- 6493-2941-02 Curva
- 276-4500-79 Guarnizione 2
- 6493-5461-47 Marmitta scarico
- 202-7565-11 Rondella
- 260-3240-31 Dado (10x1.5)
- 1-1770-06 Bullone (8x1.25) 2
- 1-7565-07 Rondella 2
- 3-3240-19 Dado (8x1.25) 2
- 291-9170-28 Terminale
- 264-7530-12 Rondella
- 202-7565-11 Rondella
- 26-1780-07 Bullone (10x1.5)
- 6221-1780-33 Bullone (10x1.5)
- 6493-8545-48 Staffa



CATALOGO GENERALE RICAMBI

NOTE - REMARQUES - REMARKS

-Vedi anche Tav. }
-Voir aussi Table } 4-71-1
-See also Table }

* NON FORNITO SCIOLTO
NON LIVRE SEPARÉMENT
NOT SUPPLIED SEPARATELY

COMPLESSIVO - GROUPE - ASSEMBLY		TAVOLA TABLE	4	42	6
MOTORE O VERSIONE MOTEUR OU ADAPTATION ENGINE OR VERSION	LDAM 96 (K.9962.09)	FOGLIO FEUILLE PAGE			
MARMITTA SCARICO VERSIONE MARINA POT D'ÉCHAPPEMENT VERSION MARINE MARINE VERSION EXHAUST MUFFLER		DATA DATE	2-73		

NOTE - REMARQUES - REMARKS

(a)
-Vedi anche Tav. }
-Voir aussi Table } 4-61-3
-See also Table }

-Motore avviamento elettrico con motorino.
-Moteur démarrage électrique avec démarreur.
-For electrical starting with motor.

* NON FORNITO SCIOLTO
NON LIVRE SEPARÉMENT
NOT SUPPLIED SEPARATELY

COMPLESSIVO - GROUPE - ASSEMBLY		TAVOLA TABLE	4	42	7
MOTORE O VERSIONE MOTEUR OU ADAPTATION ENGINE OR VERSION	LDA 96-97-100 (K.9962.06)	FOGLIO FEUILLE PAGE			
MARMITTA SCARICO POT D'ÉCHAPPEMENT EXHAUST MUFFLER		DATA DATE	2-73		



270-4775-39
Guarnizione 2

270-6800-50
Prigioniero (10x1.5) 2

202-7565-11
Rondella 2

270-3240-53
Dado (10x1.5) 2

406-1780-05
Bullone (10x1.5) 2

6493-9541-08
Tubo scarico

270-4775-39
Guarnizione

6493-5460-82
Marmitta scarico

270-3240-53
Dado (10x1.5) 2

202-7565-11
Rondella 2

NOTE - REMARQUES - REMARKS

-Motore avviamento elettrico con dinamo motore.
-Moteur démarrage électrique avec dynastart.
-Engine electrical starting with starter generator.

* NON FORNITO SCOLTO
NON LIVRE SEPAREMENT
NOT SUPPLIED SEPARATELY

COMPLESSIVO - GROUPE - ASSEMBLY		TAVOLA TABLE	4	42	8
MOTORE O VERSIONE MOTEUR OU ADAPTATION ENGINE OR VERSION	LDA 96-97-100 (K.9962.05)	MARMITTA SCARICO POT D'ÉCHAPPEMENT EXHAUST MUFFLER	FOGLIO FEUILLE PAGE		
			DATA DATE	2-73	

1-7565-04
Rondella

405-3240-08
Dado (6x1)

6335-1760-38
Bullone (6x1)

270-4775-39
Guarnizione 2

30-7555-08
Rondella 2

270-6800-50
Prigioniero (10x1.5) 2

270-3240-53
Dado (10x1.5) 2

6493-1760-51
Bullone (6x1)

6493-2751-44
Coperchio

405-3240-08
Dado (6x1)

1-7565-04
Rondella

6493-2470-92
Collare

6493-9541-62
Tubo scarico

NOTE - REMARQUES - REMARKS

* NON FORNITO SCOLTO
NON LIVRE SEPAREMENT
NOT SUPPLIED SEPARATELY

COMPLESSIVO - GROUPE - ASSEMBLY		TAVOLA TABLE	4	42	9
MOTORE O VERSIONE MOTEUR OU ADAPTATION ENGINE OR VERSION	LDA 96-97-100 (K.9962.51)	TUBO SCARICO VERTICALE TUYAU D'ÉCHAPPEMENT VERTICAL VERTICAL EXHAUST PIPE	FOGLIO FEUILLE PAGE		
			DATA DATE	2-73	



		NOTE - REMARQUES - REMARKS	
COMPLESSIVO - GROUPE - ASSEMBLY		* NON FORNITO SCIOLTO NON LIVRE SEPAREMENT NOT SUPPLIED SEPARATELY	
MOTORE O VERSIONE MOTEUR OU ADAPTATION ENGINE OR VERSION	LDA 96-97-100 (K.9962.16)	MARMITTA SCARICO AD IMBUTO POT D'ÉCHAPPEMENT A ENTENNOIR FUNNEL EXHAUST MUFFLER	TAVOLA TABLE 4 42 10 FOGLIO FEUILLE PAGE DATA DATE 2-73

		NOTE - REMARQUES - REMARKS	
COMPLESSIVO - GROUPE - ASSEMBLY		* NON FORNITO SCIOLTO NON LIVRE SEPAREMENT NOT SUPPLIED SEPARATELY	
MOTORE O VERSIONE MOTEUR OU ADAPTATION ENGINE OR VERSION	LDA 96-97-100 (K.9962.07)	MARMITTA SCARICO AD IMBUTO POT D'ÉCHAPPEMENT A ENTENNOIR FUNNEL EXHAUST MUFFLER	TAVOLA TABLE 4 42 11 FOGLIO FEUILLE PAGE DATA DATE 2-73



CATALOGO GENERALE RICAMBI

270-6800-50
Prigioniero (40x1.5) 2

30-7555-08
Rondella 2

270-3240-53
Dado (40x1.5) 2

406-1780-05
Bullone (10x1.5) 2

202-7565-41
Rondella 2

270-4775-39
Guarnizione 2

8021-9541-03
Tubo scarico

270-4775-39
Guarnizione

272-5460-07
Marmitta scarico

270-3240-53
Dado (40x1.5) 2

1.500

NOTE - REMARQUES - REMARKS

* NON FORNITO SCIOLTO
NON LIVRE SEPARÉMENT
NOT SUPPLIED SEPARATELY

COMPLESSIVO - GROUPE - ASSEMBLY		TAVOLA TABLE	4	42	12
MOTORE O VERSIONE MOTEUR OU ADAPTATION ENGINE OR VERSION	LDA 96-97-100 (K.9962.04)	TUBO SCARICO CON MARMITTA TUYAU AVEC POT D'ÉCHAPPEMENT EXHAUST PIPE WITH MUFFLER	FOGLIO FEUILLE PAGE		
			DATA DATE	2 - 73	

270-6800-50
Prigioniero (40x1.5) 2

30-7555-08
Rondella 2

270-3240-53
Dado (40x1.5) 2

406-1780-05
Bullone (10x1.5) 2

202-7565-41
Rondella 2

270-4775-39
Guarnizione 2

8021-9541-69
Tubo scarico

270-4775-39
Guarnizione

272-5460-07
Marmitta

270-3240-53
Dado (40x1.5) 2

1.500

NOTE - REMARQUES - REMARKS

-Motore avviamento elettrico con dinamo motore.
-Moteur démarrage électrique avec dynastart.
-Engine electrical starting with starter generator.

* NON FORNITO SCIOLTO
NON LIVRE SEPARÉMENT
NOT SUPPLIED SEPARATELY

COMPLESSIVO - GROUPE - ASSEMBLY		TAVOLA TABLE	4	42	13
MOTORE O VERSIONE MOTEUR OU ADAPTATION ENGINE OR VERSION	LDA 96-97-100 (K.9962.56)	TUBO SCARICO CON MARMITTA TUYAU AVEC POT D'ÉCHAPPEMENT EXHAUST PIPE WITH MUFFLER	FOGLIO FEUILLE PAGE		
			DATA DATE	2 - 73	



NOTE - REMARQUES - REMARKS

* NON FORNITO SCOLTO
NON LIVRE SEPAREMENT
NOT SUPPLIED SEPARATELY

COMPLESSIVO - GROUPE - ASSEMBLY		TAVOLA TABLE	4	42	14
MOTORE O VERSIONE MOTEUR OU ADAPTATION ENGINE OR VERSION	LDAM 96 (K.9972.16)	FOGLIO FEUILLE PAGE			
		DATA DATE	2-73		

TUBO SCARICO VERSIONE MARINA
TUYAU D'ÉCHAPPEMENT VERSION MARINE
MARINE VERSION EXHAUST PIPE

NOTE - REMARQUES - REMARKS

* NON FORNITO SCOLTO
NON LIVRE SEPAREMENT
NOT SUPPLIED SEPARATELY

COMPLESSIVO - GROUPE - ASSEMBLY		TAVOLA TABLE	4	42	15
MOTORE O VERSIONE MOTEUR OU ADAPTATION ENGINE OR VERSION	LDAM 96 (K.9972.17)	FOGLIO FEUILLE PAGE			
		DATA DATE	2-73		

TUBO SCARICO VERSIONE MARINA
TUYAU D'ÉCHAPPEMENT VERSION MARINE
MARINE VERSION EXHAUST PIPE

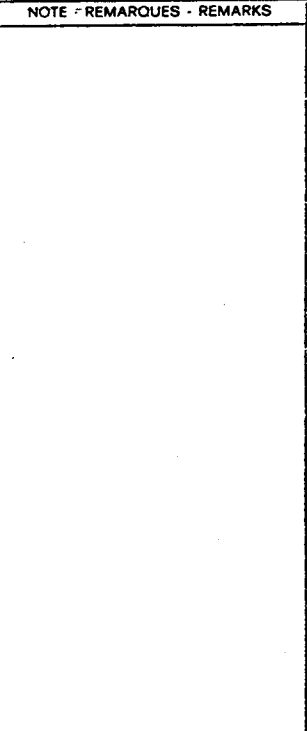

* N° FORNITO SCIOLTO
N° LIVRE SEPARÉMENT
NOT SUPPLIED SEPARATELY

COMPLESSIVO - GROUPE - ASSEMBLY	
MOTORE O VERSIONE MOTEUR OU ADAPTATION ENGINE OR VERSION	LDAM 96 (K.9972.18)

TUBO SCARICO VERSIONE MARINA
TUYAU D'ÉCHAPPEMENT VERSION MARINE
MARINE VERSION EXHAUST PIPE

TAVOLA TABLE	4	42	16
FOGLIO FEUILLE PAGE			
DATA DATE	2 - 73		

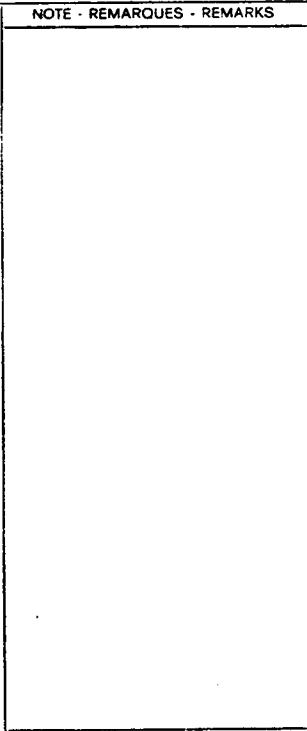

* NON FORNITO SCIOLTO
NON LIVRE SEPARÉMENT
NOT SUPPLIED SEPARATELY

COMPLESSIVO - GROUPE - ASSEMBLY	
MOTORE O VERSIONE MOTEUR OU ADAPTATION ENGINE OR VERSION	LDAM 96 (K.9972.19)

TUBO SCARICO VERSIONE MARINA
TUYAU D'ÉCHAPPEMENT VERSION MARINE
MARINE VERSION EXHAUST PIPE

TAVOLA TABLE	4	42	17
FOGLIO FEUILLE PAGE			
DATA DATE	2 - 73		



CATALOGO GENERALE RICAMBI

200-1900-02 (a) Bullone (8x1)

200-4670-03 (a) Guarnizione

270-9032-06 TAPPO COMPL.

45-1200-15 Anello OR

270-8101-18 SERBATOIO COMPL.

* **270-8101-70** Serbatoio

1-3240-18 Dado (8x1,25) 2

1-7565-07 Rondella 2

270-9570-39 (b) Tubo compl.

260-7270-20 Raccordo 2

285-3630-50 Fascella 2

260-7270-20 Raccordo

285-3630-50 Fascella 2

270-9570-67 (b) Tubo compl.

47-1770-07 Bullone (8x1,25) 2

1-7565-07 Rondella 2

5-1770-11 Bullone (8x1,25) 2

270-3525-93 Distanziale 2

45-7625-12 Rondella 2

NOTE - REMARQUES - REMARKS

(a) -Da LDA 96 N° 549804 fino a N° 779149.
-A partir de LDA 96 N° 549804 jusqu'au N° 779149.
-Starting from LDA 96 N° 549804 up to N° 779149.

-Da LDA 97 N° 550652 fino a N° 825288.
-A partir de LDA 97 N° 550652 jusqu'au N° 825288.
-Starting from LDA 97 N° 550652 up to N° 825288.

-Da LDA 100 N° 543371 fino a N° 824019.
-A partir de LDA 100 N° 543371 jusqu'au N° 824019.
-Starting from LDA 100 N° 543371 up to N° 824019.

-Fino a }
-Jusqu'au } LDA 820 N° 801415
-Below }

(b)

-Da } LDA 96 N° 779150
-A partir de } LDA 97 N° 825289
-Starting from } LDA 100 N° 824020
 } LDA 820 N° 801416

* NON FORNITO SCIOLTO
NON LIVRE SEPARÉMENT
NOT SUPPLIED SEPARATELY

COMPLESSIVO - GROUPE - ASSEMBLY		SERBATOIO COMBUSTIBILE STANDARD	TAVOLA	4	43	1
MOTORE O VERSIONE MOTEUR OU ADAPTATION ENGINE OR VERSION	LDA96-97-100-820	RESERVOIR COMBUSTIBLE STANDARD	FOGLIO FEUILLE PAGE			
		STANDARD FUEL TANK	DATA DATE	2 - 73		

6496-9820-79 (a) Vite 6

6496-4906-07 (a) Indicatore

270-9032-06 (a) TAPPO COMPL.

45-1200-15 (a) Anello OR

* **6496-8102-19** (a) Serbatoio

6496-9982-74 (a) SERBATOIO COMPL.

1-3240-18 (a) Dado (8x1,25) 2

1-7565-07 (b) Rondella 2

47-1770-07 (b) Bullone (8x1,25) 2

45-7625-12 (b) Rondella 2

5-1770-11 (b) Bullone (8x1,25) 2

270-3525-93 (b) Distanziale 2

1-7565-07 (b) Rondella 2

NOTE - REMARQUES - REMARKS

-Motori avviam. elettr. con motorino e dinamotore.
-Moteurs dém. électr. avec démarreur et dynastart.
-Engines el. start. with motor and starter generator.

-Con indicatore elettrico di livello.
-Avec témoin électrique du niveau.
-With electrical level gauge.

* NON FORNITO SCIOLTO
NON LIVRE SEPARÉMENT
NOT SUPPLIED SEPARATELY

COMPLESSIVO - GROUPE - ASSEMBLY		SERBATOIO COMBUSTIBILE	TAVOLA	4	43	2
MOTORE O VERSIONE MOTEUR OU ADAPTATION ENGINE OR VERSION	LDA96-97-100-820 (K.9982.74)	RESERVOIR COMBUSTIBLE	FOGLIO FEUILLE PAGE			
		FUEL TANK	DATA DATE	2 - 73		



200-4670-03
Guarnizione

200-4900-02
Bullone (8x4)

260-3630-04
Fascella

6549-9570-50
Tubo compl.

260-7270-20
Raccordo

246-4670-12
Guarnizione

260-4900-40
Bullone (10x1,5)

260-7270-22
Raccordo

260-3630-04
Fascella

6549-9372-23
Tubo compl.

***6496-8101-29**
Serbatoio

276-9043-15
Tappo

246-4670-12
Guarnizione

260-4900-40
Bullone (10x1,5)

285-3630-50
Fascella

260-7270-22
Raccordo 2

260-4900-40
Bullone (10x1,5)

246-4670-12
Guarnizione

6549-9600-76
Tubo compl.

246-4670-12
Guarnizione

26-8965-01
Tappo (10x1,5)

6496-8102-45
SERBATOIO COMPL.

NOTE - REMARQUES - REMARKS
-Vedi anche Tav. } 4-71-1
-Voir aussi Table }
-See also Table }
-Capacita' 35l.
-Contenance 35l.
-Capacity 35l.

* NON FORNITO SCIOLTO
NON LIVRE SEPARMENT
NOT SUPPLIED SEPARATELY

COMPLESSIVO - GROUPE - ASSEMBLY		TAVOLA TABLE	4	43	3
MOTORE O VERSIONE MOTEUR OU ADAPTATION ENGINE OR VERSION	LDAM 96 (K. 9968.67)	FOGLIO FEUILLE PAGE			
	SERBATOIO COMBUST. VERSIONE MARINA RESERVOIR COMBUST. VERSION MARINE MARINE VERSION FUEL TANK	DATA DATE	2 - 73		

270-8100-70
SERBATOIO COMPL.

270-3615-78
FASCETTA COMPL. 2

261-9730-32
Vite (8x1,25) 2

254-1557-07
Bloccetto 2

254-1557-18
Bloccetto 2

270-3730-05
FILTRO COMPL.

270-2175-03
Carfuccia

260-4430-71
Guarnizione

270-2605-04
Coperchio

1-3240-18
Dado (8x1,25) 2

1-7565-07
Rondella 2

270-8100-19
Serbatoio

270-9032-06
TAPPO COMPL.

45-1200-15
Anello OR

270-9290-05
Traversino

270-4545-05
Guarnizione

5-1770-11
Bullone (8x1,25) 2

1-7565-07
Rondella 2

270-8865-07
Supporto

209-1770-15
Bullone (8x1,25)

11-1770-14
Bullone (8x1,25)

270-8315-01
Spessore

270-4545-05
Guarnizione

270-9290-06
Traversino

NOTE - REMARQUES - REMARKS
-Fino a } LDA 96 N° 549803
-Jusqu'au } LDA 97 N° 550651
-Below } LDA 100 N° 543370

* NON FORNITO SCIOLTO
NON LIVRE SEPARMENT
NOT SUPPLIED SEPARATELY

COMPLESSIVO - GROUPE - ASSEMBLY		TAVOLA TABLE	4	43	4
MOTORE O VERSIONE MOTEUR OU ADAPTATION ENGINE OR VERSION	LDA 96-97-100	FOGLIO FEUILLE PAGE	1	2	
	SERBATOIO COMBUSTIBILE A BAULETTO RESERVOIR COMBUSTIBLE ARRONDI ROUND TYPE FUEL TANK	DATA DATE	2 - 73		



200-1900-02
Bullone (8x4)

200-4670-03
Guarnizione

246-4670-12
Guarnizione

246-1900-08
Bullone (8x4)

270-4892-01
Tubo compl.

4670-15
Guarnizione

270-9370-21
Tubo compl.

200-1900-02
Bullone (8x4)

270-9570-07
Tubo compl.

200-4670-03
Guarnizione

6925-14
Protezione

1-1770-01
Bullone (8x1,25)

1-7565-07
Rondella

NOTE - REMARQUES - REMARKS

-Fino a } LDA 96 N° 549803
-Jusqu'au } LDA 97 N° 550651
-Below } LDA 100 N° 543370

* NON FORNITO SCIOLTO
NON LIVRE SEPARÉMENT
NOT SUPPLIED SEPARATELY

COMPLESSIVO - GROUPE - ASSEMBLY		SERBATOIO COMBUSTIBILE A BAULETTO RESERVOIR COMBUSTIBLE ARRONDI ROUND TYPE FUEL TANK	TAVOLA TABLE	4	43	4
MOTORE O VERSIONE MOTEUR OU ADAPTATION ENGINE OR VERSION	LDA 96-97-100		FOGLIO FEUILLE PAGE	2	2	
			DATA DATE	2 - 73		

6496-8102-40
SERBATOIO COMPL.

270-3615-78
FASCETTA COMPL.

261-9730-32
Bullone (8x1,25) 2

254-1557-07
Blocchetto 2

254-1557-18
Blocchetto 2

270-3615-07
* Fascetta 2

270-4545-05
Guarnizione

270-9290-06
Traversino

1-3240-18
Dado (8x1,25) 2

1-7565-07
Rondella 2

6496-8101-73
Serbatoio *

270-9032-06
TAPPO COMPL.

45-1200-15
Anello OR

5-1770-11
Bullone (8x1,25) 2

1-7565-07
Rondella 2

270-4545-07
Guarnizione

270-9290-05
Traversino

11-1770-14
Bullone (8x1,25) 2

270-8315-01
Spessore

270-8865-07
Supporto

NOTE - REMARQUES - REMARKS

-Da } LDA 96 N° 779150
-A partir de } LDA 97 N° 825289
-Starting from } LDA 100 N° 824020
LDA 820 N° 801416

* NON FORNITO SCIOLTO
NON LIVRE SEPARÉMENT
NOT SUPPLIED SEPARATELY

COMPLESSIVO - GROUPE - ASSEMBLY		SERBATOIO COMBUSTIBILE A BAULETTO RESERVOIR COMBUSTIBLE ARRONDI ROUND TYPE FUEL TANK	TAVOLA TABLE	4	43	5
MOTORE O VERSIONE MOTEUR OU ADAPTATION ENGINE OR VERSION	LDA 96-97-100-820 (K. 9968.35)		FOGLIO FEUILLE PAGE			
			DATA DATE	2 - 73		



271-9600-57
Tubetto 4

45-1860-65
Bullone 2

45-4557-19
Blocchetto 2

45-4557-20
Blocchetto 2

*** 271-3615-92**
Fascetta 2

271-3616-09
FASCETTA COMPL.

260-9080-37
Tappo

260-4650-55
Guarnizione

260-4900-67
Bullone

4670-15
Guarnizione

6549-9370-46
Tubo compl.

8021-3206-19
Dado 2

8021-3206-20
Dado 2

270-9032-06
TAPPO COMPL.

45-4200-15
Anello OR

6549-9570-44
Tubo compl.

273-8101-66 *
Serbatoio

273-8101-21
SERBATOIO COMPL.

1002-9731-23
Vite (12x1.5) 4

105-7565-13
Rondella 4

8021-8865-53
Supporto

NOTE - REMARQUES - REMARKS

- Lato volano.
- Côte volant.
- Flywheel side.
- Capacità 5.5 l.
- Contenance 5.5 l.
- Capacity 5.5 l.

* NON FORNITO SCIOLTO
NON LIVRE SEPARÉMENT
NOT SUPPLIED SEPARATELY

COMPLESSIVO - GROUPE - ASSEMBLY		SERBATOIO COMBUSTIBILE RESERVOIR COMBUSTIBLE FUEL TANK	TAVOLA TABLE	4	43	6
MOTORE O VERSIONE MOTEUR OU ADAPTATION ENGINE OR VERSION	LDA 96-97-100-820 (K. 9966.34)		FOGLIO FEUILLE PAGE			
			DATA DATE	2-73		

6496-9043-25
TAPPO COMPL.

6496-8102-41
SERBATOIO COMPL.

47-4770-07
Bullone (8x1.25) 2

6496-8101-62 *
Serbatoio

NOTE - REMARQUES - REMARKS

- Capacità 7.5 l.
- Contenance 7.5 l.
- Capacity 7.5 l.

* NON FORNITO SCIOLTO
NON LIVRE SEPARÉMENT
NOT SUPPLIED SEPARATELY

COMPLESSIVO - GROUPE - ASSEMBLY		SERBATOIO COMBUST. DI MINIMO SPESSORE RESERVOIR COMBUST. ENCOMBREMENT MINIME MINIMAL WIDTH FUEL TANK	TAVOLA TABLE	4	43	7
MOTORE O VERSIONE MOTEUR OU ADAPTATION ENGINE OR VERSION	LDA 96-97-100-820 (K. 9968.26)		FOGLIO FEUILLE PAGE			
			DATA DATE	2-73		



CATALOGO GENERALE RICAMBI

270-9570-39
Tubo compl.

1021-3616-16
* Fascetta

254-1557-18
Bocchetto 2

254-1557-07
Bocchetto 2

260-9730-36
Vite (8x1.25) 2

6193-3616-92
FASCETTA COMPL.

260-4700-61
Guarnitura

8021-8865-59
Supporto

47-1770-07
Bullone (8x1.25) 4

25-9032-09
TAPPO COMPL.

270-9570-67
Tubo compl.

6496-8102-24
* Serbatoio

6496-8102-43
SERBATOIO COMPL.

270-4545-05
Guarnizione

9290-10
Traversino

4545-07
Guarnizione

1-3240-18
Dado (8x1.25) 4

250-7555-07
Rondella 4

NOTE - REMARQUES - REMARKS

-Capacità 8,5 l.
-Contenance 8,5 l.
-Capacity 8,5 l.

(a)-Da LDA 96 N° 549804 fino a N° 779149.
-A partir de LDA 96 N° 549804 jusqu'au N° 779149.
-Starting from LDA 96 N° 549804 up to N° 779149.

-Da LDA 97 N° 550652 fino a N° 825288.
-A partir de LDA 97 N° 550652 jusqu'au N° 825288.
-Starting from LDA 97 N° 550652 up to N° 825288.

-Da LDA 100 N° 543371 fino a N° 824019.
-A partir de LDA 100 N° 543371 jusqu'au N° 824019.
-Starting from LDA 100 N° 543371 up to N° 824019.

-Fino a }
-jusqu'au } LDA 820 N° 801415
-Below }

(b)-Da LDA 96 N° 779150
-A partir de LDA 97 N° 825289
-Starting from LDA 100 N° 824020
LDA 820 N° 801416

* NON FORNITO SCIOLTO
NON LIVRE SEPARÉMENT
NOT SUPPLIED SEPARATELY

COMPLESSIVO - GROUPE - ASSEMBLY		SERBATOIO COMBUST. DI MINIMO SPESSORE RESERVOIR COMBUST. ENCOMBREMENT MINIME MINIMAL WIDTH FUEL TANK		TAVOLA TABLE	4	43	8
MOTORE O VERSIONE MOTEUR OU ADAPTATION ENGINE OR VERSION	LDA 96-97-100-820 (K. 9968.13)			FOGLIO FEUILLE PAGE	1	2	
				DATA DATE	2-73		

406-1770-05
Bullone (8x1.25) 2

5-7625-40
Rondella 2

1-7565-07
Rondella 2

1-3240-18
Bullone (8x1.25) 2

202-7565-11
Rondella 2

7-1780-04
Bullone (10x1.5) 2

8760-09
Supporto

260-1900-67
Bullone

4670-15
Guarnizione

6549-9370-46
Tubo compl.

246-4670-12
Guarnizione 2

260-1900-40
Bullone (10x1.5)

6549-9370-47
Tubo compl.

260-4650-55
Guarnizione

246-1900-08
Bullone (10x1)

246-4670-12
Guarnizione 2

260-9080-37
Tappo

260-3730-04
Filtro

246-4670-12
Guarnizione 2

260-1900-67
Bullone (10x1)

NOTE - REMARQUES - REMARKS

-Capacità 8,5 l.
-Contenance 8,5 l.
-Capacity 8,5 l.

* NON FORNITO SCIOLTO
NON LIVRE SEPARÉMENT
NOT SUPPLIED SEPARATELY

COMPLESSIVO - GROUPE - ASSEMBLY		SERBATOIO COMBUST. DI MINIMO SPESSORE RESERVOIR COMBUST. ENCOMBREMENT MINIME MINIMAL WIDTH FUEL TANK		TAVOLA TABLE	4	43	8
MOTORE O VERSIONE MOTEUR OU ADAPTATION ENGINE OR VERSION	LDA 96-97-100-820 (K. 9968.13)			FOGLIO FEUILLE PAGE	2	2	
				DATA DATE	2-73		



CATALOGO GENERALE RICAMBI

NOTE - REMARQUES - REMARKS

- Capacità 12 l.
- Contenance 12 l.
- Capacity 12 l.

COMPRESSIVO - GROUPE - ASSEMBLY

MOTORE O VERSIONE
MOTEUR OU ADAPTATION
ENGINE OR VERSION

LDA 96-97-100-820
(K. 9967.74)

SERBATOIO COMBUST. SPESSORE RIDOTTO
RESERVOIR COMBUST. ENCOMBREMENT REDUIT
REDUCED WIDTH FUEL TANK

TAVOLA TABLE	4	43	9
FOGLIO FEUILLE PAGE	1	2	
DATA DATE	2-73		

* NON FORNITO SCIOLTO
NON LIVRE SEPAREMENT
NOT SUPPLIED SEPARATELY

NOTE - REMARQUES - REMARKS

- Capacità 12 l.
- Contenance 12 l.
- Capacity 12 l.

COMPRESSIVO - GROUPE - ASSEMBLY

MOTORE O VERSIONE
MOTEUR OU ADAPTATION
ENGINE OR VERSION

LDA 96-97-100-820
(K. 9967.74)

SERBATOIO COMBUST. SPESSORE RIDOTTO
RESERVOIR COMBUST. ENCOMBREMENT REDUIT
REDUCED WIDTH FUEL TANK

TAVOLA TABLE	4	43	9
FOGLIO FEUILLE PAGE	2	2	
DATA DATE	2-73		

* NON FORNITO SCIOLTO
NON LIVRE SEPAREMENT
NOT SUPPLIED SEPARATELY



CATALOGO GENERALE RICAMBI

NOTE - REMARQUES - REMARKS

- Capacita' 71.
- Confenance 71.
- Capacity 71.

* NON FORNITO SCIOLTO
NON LIVRE SEPARMENT
NOT SUPPLIED SEPARATELY

COMPLESSIVO - GROUPE - ASSEMBLY		TAVOLA TABLE	4	43	10
MOTORE O VERSIONE MOTEUR OU ADAPTATION ENGINE OR VERSION	LDA 96-97-100-820 (K. 9965.77)	SERBATOIO COMBUST. SPESSORE RIDOTTO RESERVOIR COMBUST. ENCOMBREMENT REDUIT REDUCED WIDTH FUEL TANK	FOGLIO FEUILLE PAGE	1	2
			DATA DATE	2-73	

NOTE - REMARQUES - REMARKS

- Capacita' 71.
- Confenance 71.
- Capacity 71.

* NON FORNITO SCIOLTO
NON LIVRE SEPARMENT
NOT SUPPLIED SEPARATELY

COMPLESSIVO - GROUPE - ASSEMBLY		TAVOLA TABLE	4	43	10
MOTORE O VERSIONE MOTEUR OU ADAPTATION ENGINE OR VERSION	LDA 96-97-100-820 (K. 9965.77)	SERBATOIO COMBUST. SPESSORE RIDOTTO RESERVOIR COMBUST. ENCOMBREMENT REDUIT REDUCED WIDTH FUEL TANK	FOGLIO FEUILLE PAGE	2	2
			DATA DATE	2-73	



6014-8545-43
Staffa

272-1511-69
Basamento compl.
LDA 96-97-LDAM 96.

279-1511-81
Basamento compl.
LDA 100.

291-1512-04
Basamento compl.
LDA 820.

270-8900-57
Supporto

270-6495-12
Pistoncino

270-6605-05
POMPA OLIO COMPL.

4950-42
Ingranaggio

270-2840-38
Corpo pompa

*** 255-4580-06**
Guarnizione

*** 270-4580-32**
Guarnizione 0.50

*** 270-4580-33**
Guarnizione 0.80

6416-6585-07
Pompa alimentaz.

260-7270-22
Raccordo

260-3630-04
Fascella 2

260-7270-23
Raccordo

6549-9372-01
Tubo compl.

246-1900-08
Bullone (40x1)

246-4670-12
Guarnizione

236-6780-12
Prigioniero(8x1.25)

250-7555-07
Rondella 2

1-3240-18
Dado (8x1.25) 2

6549-9371-91
Tubo compl.

260-7270-22
Raccordo

260-3630-04
Fascella

6549-9371-99
Tubo compl.

273-7300-57
Raccordo

NOTE - REMARQUES - REMARKS

-Da } LDA 96 N° 497645
-A partir de } LDAM 96 N° 505954
-Starting from } LDA 97 N° 505954

(a) -Vedi anche Tav. }
-Voir aussi Table } 4-21-4
-See also Table }

(b) -Vedi anche Tav. }
-Voir aussi Table } 4-51-1
-See also Table }

(c) -Solo LDA 96-97-100-LDAM 96
-Seulement LDA 96-97-100-LDAM 96
sans réservoir.
-Only LDA 96-97-100-LDAM 96
without fuel tank.

(d) -Solo motore con serbatoio.
-Seulement moteur avec réservoir.
-Only engine with fuel tank.

(e) LDA 96-97-100-LDAM 96 con
serbatoio; LDA 820 con e senza
serbatoio.
-LDA 96-97-100-LDAM 96 avec résér-
voir; LDA 820 avec et sans résér-
voir.
-LDA 96-97-100-LDAM 96 with fuel
tank; LDA 820 with and without
fuel tank.

(f) -Solo LDA 100-820 avviat. electr.
con motorino.
-Seulement LDA 100-820 dém. électr.
avec démarreur.
-Only LDA 100-820 el. start. with
motor.

* NON FORNITO SCIOLTO
NON LIVRE SEPARÉMENT
NOT SUPPLIED SEPARATELY

COMPLESSIVO - GROUPE - ASSEMBLY				
MOTORE O VERSIONE MOTEUR OU ADAPTATION ENGINE OR VERSION	K.9967.72 - 9967.17 9983.04 - 9983.89 9980.90 - 9981.06 9981.07	POMPA ALIMENTAZIONE POMPE D'ALIMENTATION FUEL FEEDING PUMP	TAVOLA TABLE	4 44 1
			FOGLIO FEUILLE PAGE	
			DATA DATE	2-73

260-9730-27
Vite (8x1.25) 3

1-7565-07
Rondella 3

270-6590-07
Pompa

279-6590-16
Pompa

*** 260-4580-01**
Guarnizione 0.10-2

*** 260-4580-12**
Guarnizione 0.30-2

*** 260-4580-08**
Guarnizione 0.50-2

260-5390-06
Manicotto

270-3615-43
Fascella

270-9370-09
Tubo

270-1580-16
Boccola

1-2800-03
Copiglia

27-7625-05
Rondella

NOTE - REMARQUES - REMARKS

(a) -Fino a } LDA 96 N° 4056025
-Jusqu'au } LDAM 96 N° 4056025
-Below } LDA 97 N° 4044851

(b) -Da } LDA 96 N° 4056025
-A partir de } LDAM 96 N° 4056025
-Starting from } LDA 97 N° 4044852

* NON FORNITO SCIOLTO
NON LIVRE SEPARÉMENT
NOT SUPPLIED SEPARATELY

COMPLESSIVO - GROUPE - ASSEMBLY				
MOTORE O VERSIONE MOTEUR OU ADAPTATION ENGINE OR VERSION		POMPA INIEZIONE POMPE INJECTION INJECTION PUMP	TAVOLA TABLE	4 45 1
			FOGLIO FEUILLE PAGE	1 2
			DATA DATE	2-73



NOTE - REMARQUES - REMARKS

(C) -Fino a LDA 96 N° 549803
 -Jusqu'au LDAM96 N° 549803
 -Below LDA 97 N° 550651
 LDA 100 N° 543370

* NON FORNITO SCOLTO
 NON LIVRE SEPARMENT
 NOT SUPPLIED SEPARATELY

COMPLESSIVO - GROUPE - ASSEMBLY		POMPA INIEZIONE	TAVOLA TABLE	4	45	1
MOTORE O VERSIONE MOTEUR OU ADAPTATION ENGINE OR VERSION		POMPE INJECTION	FOGLIO FEUILLE PAGE	2	2	
		INJECTION PUMP	DATA DATE	2 - 73		

NOTE - REMARQUES - REMARKS

(a) -Fino a LDA 96 N° 497643
 -Jusqu'au LDAM96 N° 497643
 -Below LDA 97 N° 505953

(b) -Da LDA 96-LDAM96 N° 497644 fino a N° 1056025.
 -A partir de LDA 96-LDAM 96 N° 497644 jusqu'au N° 1056025.
 -Starting from LDA 96 -LDAM 96 N° 497644 below N° 1056025.

-Da LDA 97 N° 505954 fino a N° 1044851.
 -A partir de LDA 97 N° 505954 jusqu'au N° 1044851.
 -Starting from LDA 97 N° 505954 up to N° 1044851.

(c) -Da LDA 96
 -A partir de LDAM96 N° 1056026
 -Starting from LDA 97 N° 1044852

* NON FORNITO SCOLTO
 NON LIVRE SEPARMENT
 NOT SUPPLIED SEPARATELY

COMPLESSIVO - GROUPE - ASSEMBLY		POMPA INIEZIONE (PARTICOLARI)	TAVOLA TABLE	4	45	2
MOTORE O VERSIONE MOTEUR OU ADAPTATION ENGINE OR VERSION		POMPE INJECTION (PIECES DETACHEES)	FOGLIO FEUILLE PAGE			
		INJECTION PUMP (COMPONENTS)	DATA DATE	2 - 73		



<p>270-9570-39 ✓ TUBO COMPL.</p> <p>285-3630-50 Fascetta 2</p> <p>200-1900-02 Bullone (8x1) 2</p> <p>260-7270-20 Raccordo 2</p> <p>200-4670-03 Guarnizione 2</p> <p>1-3240-18 Dado (8x1,25) 2</p> <p>1-7565-07 Rondella 2</p> <p>27-6780-18 Prigioniero (8x1,25) 2</p> <p>260-4670-09 Guarnizione 0,50</p> <p>260-4670-10 Guarnizione 1</p> <p>260-4670-11 Guarnizione 1,50</p>		<p>270-9570-67 ✓ TUBO COMPL.</p> <p>285-3630-50 Fascetta 2</p> <p>260-7270-20 Raccordo</p> <p>200-4670-03 Guarnizione 2</p> <p>260-6615-01 Portapolverizz.</p> <p>292-6531-13 Polverizzatore</p> <p>279-6531-09 Polverizzatore LDA 100.</p> <p>270-6531-07 Polverizzatore LDA 96-97-LDAM96.</p> <p>291-6615-15 PORTAPOLVERIZZ. COMPL.</p> <p>279-6615-09 PORTAPOLVERIZZ. COMPL.</p> <p>270-6615-06 PORTAPOLVERIZZ. COMPL.</p>		<p>NOTE - REMARQUES - REMARKS</p> <p>(a) -Da LDA96-LDAM96 N° 549804 fino a N° 779149. -A partir de LDA96-LDAM96 N° 549804 jusqu'au N° 779149. -Starting from LDA96-LDAM96 N° 549804 below N° 779149.</p> <p>-Da LDA97 N° 550652 fino a N° 825288 -A partir de LDA97 N° 550652 jusqu'au N° 825288. -Starting from LDA97 N° 550652 up to N° 825288.</p> <p>-Da LDA 100 N° 543371 fino a N° 824019. -A partir de LDA 100 N° 543371 jusqu'au N° 824019. -Starting from LDA 100 N° 543371 up to N° 824019.</p> <p>-Fino a) -Jusqu'au) LDA 820 N° 801415 -Below)</p> <p>(b) -Da LDA96 N° 779150 -A partir de LDAM96 N° 825289 -Starting from LDA97 N° 824020 LDA 100 N° 801416</p> <p>(c) -Da LDA96 N° 1056026 -A partir de LDAM96 N° 1044852 -Starting from LDA97 N° 1044851 LDA 100 N° 1056838</p> <p>-Fino a) LDA96 N° 1056025 -Jusqu'au) LDA96 N° 1044851 -Below) LDA97 N° 1044851 LDA 100 N° 1056837</p> <p>* NON FORNITO SCIOLTO NON LIVRE SEPARÉMENT NOT SUPPLIED SEPARATELY</p>											
<p>COMPLESSIVO - GROUPE - ASSEMBLY</p> <p>MOTORE O VERSIONE MOTEUR OU ADAPTATION ENGINE OR VERSION</p>		<p>PORTAPOLVERIZZATORE E POLVERIZZATORE PORTE-INJECTEUR ET INJECTEUR NOZZLE HOLDER AND NOZZLE</p>	<table border="1"> <tr> <td>TAVOLA TABLE</td> <td>4</td> <td>45</td> <td>3</td> </tr> <tr> <td>FOGLIO FEUILLE PAGE</td> <td></td> <td></td> <td></td> </tr> <tr> <td>DATA DATE</td> <td colspan="3">2-73</td> </tr> </table>	TAVOLA TABLE	4	45	3	FOGLIO FEUILLE PAGE				DATA DATE	2-73		
TAVOLA TABLE	4	45	3												
FOGLIO FEUILLE PAGE															
DATA DATE	2-73														

<p>260-4130-53 Ghiera.</p> <p>260-4370-07 Guarnizione</p> <p>260-5800-38 Molla.</p> <p>* 260-2870-12 Corpo</p> <p>270-6531-07 Polverizzatore LDA 96-97-LDAM96.</p> <p>279-6531-09 Polverizzatore LDA 100.</p> <p>292-6531-13 Polverizzatore</p>		<p>200-1900-02 Bullone (8x1)</p> <p>260-1570-16 Bocchettone</p> <p>260-8010-02 Sede</p> <p>260-1420-12 Asta</p> <p>260-7300-35 Raccordo</p> <p>260-4650-37 Guarnizione</p> <p>260-4130-52 Ghiera.</p>		<p>NOTE - REMARQUES - REMARKS</p> <p>(a) -Fino a) LDA 96 N° 1056025 -Jusqu'au) LDAM96 N° 1044851 -Below) LDA 97 N° 1044851</p> <p>(b) -Fino a) LDA 100 N° 1056837 -Jusqu'au)</p> <p>(c) -Da LDA96 N° 1056026 -A partir de LDAM96 N° 1044852 -Starting from LDA97 N° 1044851 LDA 100 N° 1056838</p> <p>* NON FORNITO SCIOLTO NON LIVRE SEPARÉMENT NOT SUPPLIED SEPARATELY</p>											
<p>COMPLESSIVO - GROUPE - ASSEMBLY</p> <p>MOTORE O VERSIONE MOTEUR OU ADAPTATION ENGINE OR VERSION</p>		<p>PORTAPOLVERIZZ. E POLVERIZZ. (PARTICOLARI) PORTE-INJ. ET INJ. (PIECES DETACHEES) NOZZLE HOLDER AND NOZZLE (COMPONENTS)</p>	<table border="1"> <tr> <td>TAVOLA TABLE</td> <td>4</td> <td>45</td> <td>4</td> </tr> <tr> <td>FOGLIO FEUILLE PAGE</td> <td></td> <td></td> <td></td> </tr> <tr> <td>DATA DATE</td> <td colspan="3">2-73</td> </tr> </table>	TAVOLA TABLE	4	45	4	FOGLIO FEUILLE PAGE				DATA DATE	2-73		
TAVOLA TABLE	4	45	4												
FOGLIO FEUILLE PAGE															
DATA DATE	2-73														



CATALOGO GENERALE RICAMBI

MOTORE MOTEUR ENGINE	MARCA MARQUE MAKE	POMPA INIEZIONE POMPE INJECTION INJECTION PUMP	POM PANTE PISTON PLONGEUR INJ. PLUNGER & BARREL	VALVOLA MANDATA CLAPET DE REFOULEN DELIVERY VALVE	MOLLA VALVOLA RESSORT DE CLAPET VALVE SPRING	POLVERIZZATORE INJECTEUR NOZZLE	PORTA POLVERIZZ. PORTE-INJECTEUR NOZZLE HOLDER	NOTE - REMARQUES - REMARKS	
LDA 96	LOMBARDINI	270-6590-07	262-6578-01	260-9672-09	260-5755-39	270-6531-07	270-6615-06		
	BOSCH	PFR 1K65/345/2	EPPK22155Z	EPVE 235 P7Z	EP5F28P24 X	DLLA 160S378	KBL 865721/4		
	LDA 97	FB				BLL 160SL 21	KBL 87 9 26		
	LDAM 96	OMAP					OLL 160S3208		OKLL8756066
		SPICA	PDT18Y65T133						
CIPA		CPFR1K65/4018	TK - 4271	AB - 4071	KA - 4135	VH - 16037	CKBL86JB/2027		
LDA 400	LOMBARDINI	279-6590-16	279-6578-09	260-9672-09	271-5755-34	279-6531-09	279-6615-09		
	BOSCH	PFR 1K70/302	EPPK22156Z	EPVE 235 P7Z	WSF40342 X	DLL 160S 150	KBL 865721/4		
	FB					BLL 160SL 100	KBL 87 5 26		
	OMAP						OKLL8756066		
	CIPA	CPFR1K70/1004	TK - 1303	AB - 4071	KA - 4042	VH - 16025	CKBL 875B2048		
LDA 820	LOMBARDINI	279-6590-16	279-6578-09	260-9672-09	271-5755-34	292-6531-13	291-6615-15		
	BOSCH	PFR 1K70/302	EPPK22156Z	EPVE 235 P7Z	WSF40342 X	DLLA 160S373	KBL 865721/4		
	OMAP						OKLL 8756066		
COMPLESSIVO - GROUPE - ASSEMBLY									* NON FORNITO SCIOLTO NON LIVRE SEPAREMENT NOT SUPPLIED SEPARATELY
MOTORE O VERSIONE MOTEUR OU ADAPTATION ENGINE OR VERSION		TABELLA COMPARATIVA MATERIALE INIEZIONE TABLEAU COMPARATIF MATERIEL INJECTION INJECTION SYSTEM REFERENCE TABLE				TAVOLA TABLE 4 45 5		FOGLIO FEUILLE PAGE	
						DATA DATE		2 - 73	

		NOTE - REMARQUES - REMARKS	
COMPLESSIVO - GROUPE - ASSEMBLY		273-3730-15	
MOTORE O VERSIONE MOTEUR OU ADAPTATION ENGINE OR VERSION		FILTRO COMBUSTIBILE FILTRE A COMBUSTIBLE FUEL FILTER	
		TAVOLA TABLE 4 47 1	
		FOGLIO FEUILLE PAGE	
		DATA DATE 2 - 73	
* NON FORNITO SCIOLTO NON LIVRE SEPAREMENT NOT SUPPLIED SEPARATELY			



270-6605-03
POMPA OLIO COMPL.

270-4950-06
Ingranaggio

260-2200-01
Chiavetta

1-7565-07
Rondella 2

422-9730-30
Vite (8x1,25) 2

250-7555-07
Rondella

270-3203-14
Dado (8x1,25)

270-4975-03
Ingranaggio

270-2840-17
Corpo pompa

270-2840-38
Corpo pompa

270-7700-14
Rondella

270-9730-10
Vite (6x1) 2

270-9320-41
Tubo

270-9320-46
Tubo

270-4950-05
Ingranaggio

4950-42
Ingranaggio

1-7625-07
Rondella

1-7565-04
Rondella

270-9730-15
Vite (6x1)

270-6605-05
POMPA OLIO COMPL.

NOTE - REMARQUES - REMARKS

(a) - Fino a LDA 96 N° 497643
- Jusqu'au LDAM96
- Below LDA 97 N° 505953

(b) - Per motori con pompa alimentaz. vedi Tav. 4-44-1.
- Pour moteur avec pompe d'aliment. voir Table 4-44-1.
- For engines with fuel feeding pump see Table 4-44-1.

* NON FORNITO SCIOLTO
NON LIVRE SEPARMENT
NOT SUPPLIED SEPARATELY

COMPLESSIVO - GROUPE - ASSEMBLY		TAVOLA TABLE	4	51	1
MOTORE O VERSIONE MOTEUR OU ADAPTATION ENGINE OR VERSION		FOGLIO FEUILLE PAGE			
		DATA DATE	2 - 73		

POMPA OLIO
POMPE A HUILE
LUB. OIL PUMP

6531-9050-29
TAPPO COMPL. DI PROTEZIONE

6531-2145-03
Cappuccio

6531-9600-64
Tubo

6193-3615-98
Fascella

202-7565-11
Rondella

8067-1780-26
Bullone (10x1,25)

70-9790-58
Vite (5x0,8)

250-5110-04
Lamiera

260-9695-04
Valvola

70-9050-11
Tappo *

70-5085-10
Lamiera

6531-5150-53
Lamiera

225-3240-04
Dado (5x0,8)

6531-4650-51
Guarnizione

6531-9050-26
TAPPO COMPL.

NOTE - REMARQUES - REMARKS

- Motore senza piedi.
- Moteur sans pieds.
- Engine without mounts.

* NON FORNITO SCIOLTO
NON LIVRE SEPARMENT
NOT SUPPLIED SEPARATELY

COMPLESSIVO - GROUPE - ASSEMBLY		TAVOLA TABLE	4	54	1
MOTORE O VERSIONE MOTEUR OU ADAPTATION ENGINE OR VERSION	(K. 9965.72)	FOGLIO FEUILLE PAGE			
		DATA DATE	2 - 73		

TAPPO SFIATO PROTETTO
BOUCHON RENIFLARD PROTEGE
PROTECTED BREATHER CAP

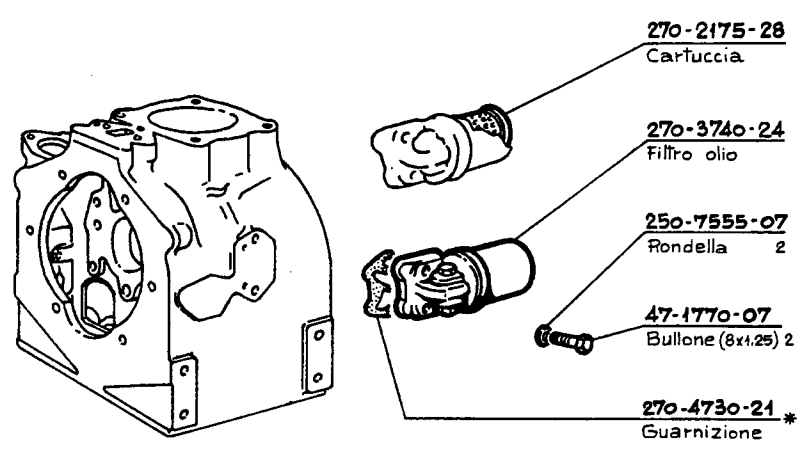

CATALOGO GENERALE RICAMBI

		<p>NOTE - REMARQUES - REMARKS</p>													
		<p>* NON FORNITO SCIOLTO NON LIVRE SEPARÉMENT NOT SUPPLIED SEPARATELY</p>													
<p>COMPLESSIVO - GROUPE - ASSEMBLY</p>		<p>FILTRO OLIO FILTRE A HUILE LUB. OIL FILTER</p>													
<p>MOTORE O VERSIONE MOTEUR OU ADAPTATION ENGINE OR VERSION</p>	<p>(K. 9978.69)</p>	<table border="1" style="width: 100%; border-collapse: collapse;"> <tr> <td>TAVOLA TABLE</td> <td style="text-align: center;">4</td> <td style="text-align: center;">57</td> <td style="text-align: center;">1</td> </tr> <tr> <td>FOGLIO FEUILLE PAGE</td> <td></td> <td></td> <td></td> </tr> <tr> <td>DATA DATE</td> <td colspan="3" style="text-align: center;">2 - 73</td> </tr> </table>	TAVOLA TABLE	4	57	1	FOGLIO FEUILLE PAGE				DATA DATE	2 - 73			
TAVOLA TABLE	4	57	1												
FOGLIO FEUILLE PAGE															
DATA DATE	2 - 73														

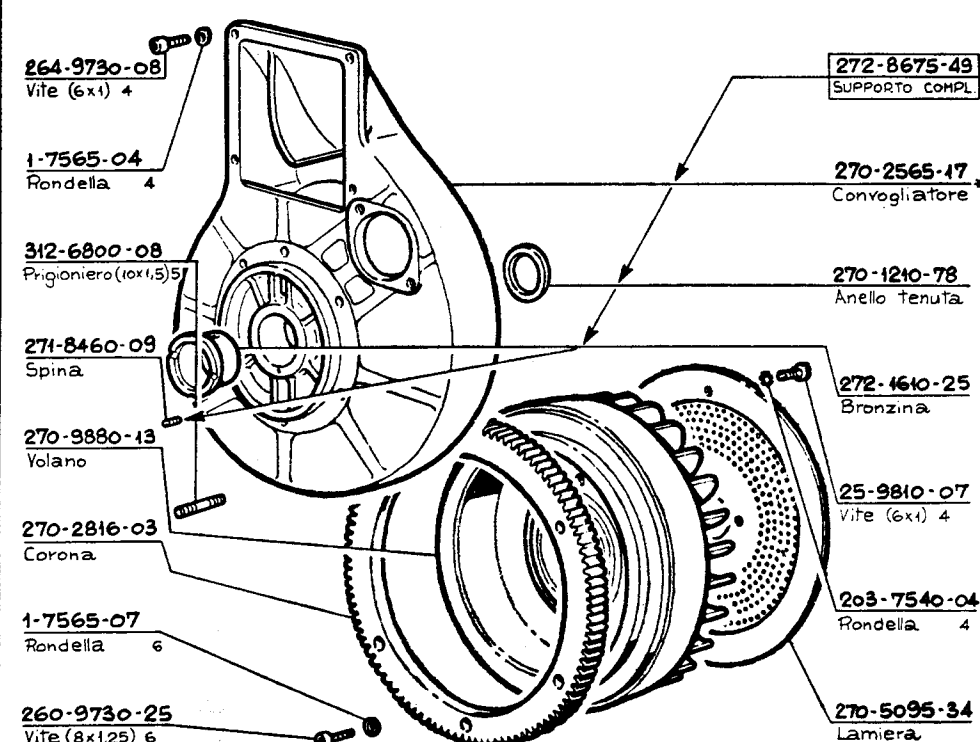
		<p>NOTE - REMARQUES - REMARKS</p> <p>-Fino a) LDA 96 N°493641 -Jusqu'au) LDAM 96 -Below) LDA 97 N°493130</p>													
		<p>* NON FORNITO SCIOLTO NON LIVRE SEPARÉMENT NOT SUPPLIED SEPARATELY</p>													
<p>COMPLESSIVO - GROUPE - ASSEMBLY</p>		<p>PREDISPOSIZIONE AVVIAMENTO ELETTRICO PREDISPOSITION DEMARRAGE ELECTRIQUE ELECTRICAL STARTING ADAPTER</p>													
<p>MOTORE O VERSIONE MOTEUR OU ADAPTATION ENGINE OR VERSION</p>	<p>LDA 96-97-LDAM 96</p>	<table border="1" style="width: 100%; border-collapse: collapse;"> <tr> <td>TAVOLA TABLE</td> <td style="text-align: center;">4</td> <td style="text-align: center;">61</td> <td style="text-align: center;">1</td> </tr> <tr> <td>FOGLIO FEUILLE PAGE</td> <td></td> <td></td> <td></td> </tr> <tr> <td>DATA DATE</td> <td colspan="3" style="text-align: center;">2 - 73</td> </tr> </table>	TAVOLA TABLE	4	61	1	FOGLIO FEUILLE PAGE				DATA DATE	2 - 73			
TAVOLA TABLE	4	61	1												
FOGLIO FEUILLE PAGE															
DATA DATE	2 - 73														



CATALOGO GENERALE RICAMBI

105-7565-13
Rondella 2

270-1790-25
Bullone (12x1,25) 2

270-6685-45
Portina

279-6800-59
Prigioniero (10x1,5)

236-6800-18
Prigioniero (10x1,5) 2

291-6371-39
Piastra

422-4775-42
Guarnizione *

270-2565-70
Convogliatore

271-7500-18
Rondella 7

260-1755-01
Bullone (5x0,8) 7

270-9881-06
Volano *

270-2816-11
Corona

270-9881-28
VOLANO COMPL.

NOTE - REMARQUES - REMARKS

* NON FORNITO SCIOLTO
NON LIVRE SEPARMENT
NOT SUPPLIED SEPARATELY

COMPLESSIVO - GROUPE - ASSEMBLY		TAVOLA TABLE	4	61	2
MOTORE O VERSIONE MOTEUR OU ADAPTATION ENGINE OR VERSION	(K. 9966.63)	FOGLIO FEUILLE PAGE			
PREDISPOSIZIONE AVVIAMENTO ELETTRICO PREDISPOSITION DEMARRAGE ELECTRIQUE ELECTRICAL STARTING ADAPTER		DATA DATE	2 - 73		

270-4775-39
Guarnizione (b)

270-4775-39
Guarnizione (b)

270-6800-50
Prigioniero (10x1,5) 2 (b)

30-7555-08
Rondella 2 (b)

270-3240-53
Dado (10x1,5) 2 (b)

270-8725-27
Supporto

202-7565-11
Rondella (b)

7-1780-04
Bullone (10x1,5) (b)

202-1770-02
Bullone (8x1,25) 4 (b)

270-2940-70
Curva scarico (b)

270-6800-50
Prigioniero (10x1,5) 2 (b)

202-7565-11
Rondella 2 (b)

270-3240-53
Dado (10x1,5) 2 (b)

209-1770-15
Bullone (8x1,25) 6 (b)

6446-6960-54
Puleggia (a)

270-5095-58
Lamiera (a)

250-7555-07
Rondella 4 (a)

NOTE - REMARQUES - REMARKS

(a)
-Vedi anche Tav. }
-Voir aussi Table } 4-31-3
-See also Table }

(b)
-Vedi anche Tav. }
-Voir aussi Table } 4-42-7
-See also Table }

* NON FORNITO SCIOLTO
NON LIVRE SEPARMENT
NOT SUPPLIED SEPARATELY

COMPLESSIVO - GROUPE - ASSEMBLY	270-1470-09	TAVOLA TABLE	4	61	3
MOTORE O VERSIONE MOTEUR OU ADAPTATION ENGINE OR VERSION	LDA 96-97-LDAM 96 (K. 9965.29)	FOGLIO FEUILLE PAGE	1	3	
AVVIAMENTO ELETTRICO CON DINAMOTORE DEMARRAGE ELECTRIQUE AVEC DYNASTART ELECTRICAL STARTING WITH STARTER GENERATOR		DATA DATE	2 - 73		



CATALOGO GENERALE RICAMBI

270-8075-27
Sempileggia

3375-02
Dinamotore

70-3615-97
Fascella 2

45-1557-20
Blocchetto 2

45-1557-19
Blocchetto 2

8061-1861-80
Bullone 2

271-7362-15
Regolatore

270-2440-14
Cinghietta

260-6760-10
Prigioniero (6x1) 3

1-7565-04
Rondella 3

105-3240-08
Dado (6x1) 3

270-3206-14
Dado

105-7565-15
Rondella

70-8075-26
Sempileggia

260-6320-04
Piastrina 0.50 - 2

260-6320-03
Piastrina 1 - 2

260-6320-05
Piastrina 2

NOTE - REMARQUES - REMARKS

* NON FORNITO SCIOLTO
NON LIVRE SEPAREMENT
NOT SUPPLIED SEPARATELY

COMPLESSIVO - GROUPE - ASSEMBLY	270-1470-09	AVVIAMENTO ELETTRICO CON DINAMOTORE DEMARRAGE ELECTRIQUE AVEC DYNASTART ELECTRICAL STARTING WITH STARTER GENERATOR	TAVOLA TABLE	4	61	3
MOTORE O VERSIONE MOTEUR OU ADAPTATION ENGINE OR VERSION	LDA96-97-LDAM96 (K. 9965.29)		FOGLIO FEUILLE PAGE	2		3
			DATA DATE	2-73		

*** 270-2125-25**
Cappello

*** 270-4400-09**
Guarnizione 0.20

*** 270-4400-08**
Guarnizione 0.30

*** 270-1540-44**
Bilanciere scarico

270-1540-60
BILANCIERE SCARICO
COMPL.

270-2125-28
CAPPELLO COMPL.

246-1165-04
Anello Benzina

270-5680-24
Molla

270-1110-38
Albero

270-5270-42
Leva

276-8430-23
Spina

268-1200-34
Anello OR

276-8430-23
Spina

NOTE - REMARQUES - REMARKS

(c)
-Vedi anche Tav. }
-Voir aussi Table } 4-37-1
-See also Table }

(d)
-Vedi anche Tav. }
-Voir aussi Table } 4-35-3
-See also Table }

* NON FORNITO SCIOLTO
NON LIVRE SEPAREMENT
NOT SUPPLIED SEPARATELY

COMPLESSIVO - GROUPE - ASSEMBLY	270-1470-09	AVVIAMENTO ELETTRICO CON DINAMOTORE DEMARRAGE ELECTRIQUE AVEC DYNASTART ELECTRICAL STARTING WITH STARTER GENERATOR	TAVOLA TABLE	4	61	3
MOTORE O VERSIONE MOTEUR OU ADAPTATION ENGINE OR VERSION	LDA96-97-LDAM 96 (K. 9965.29)		FOGLIO FEUILLE PAGE	3		3
			DATA DATE	2-73		

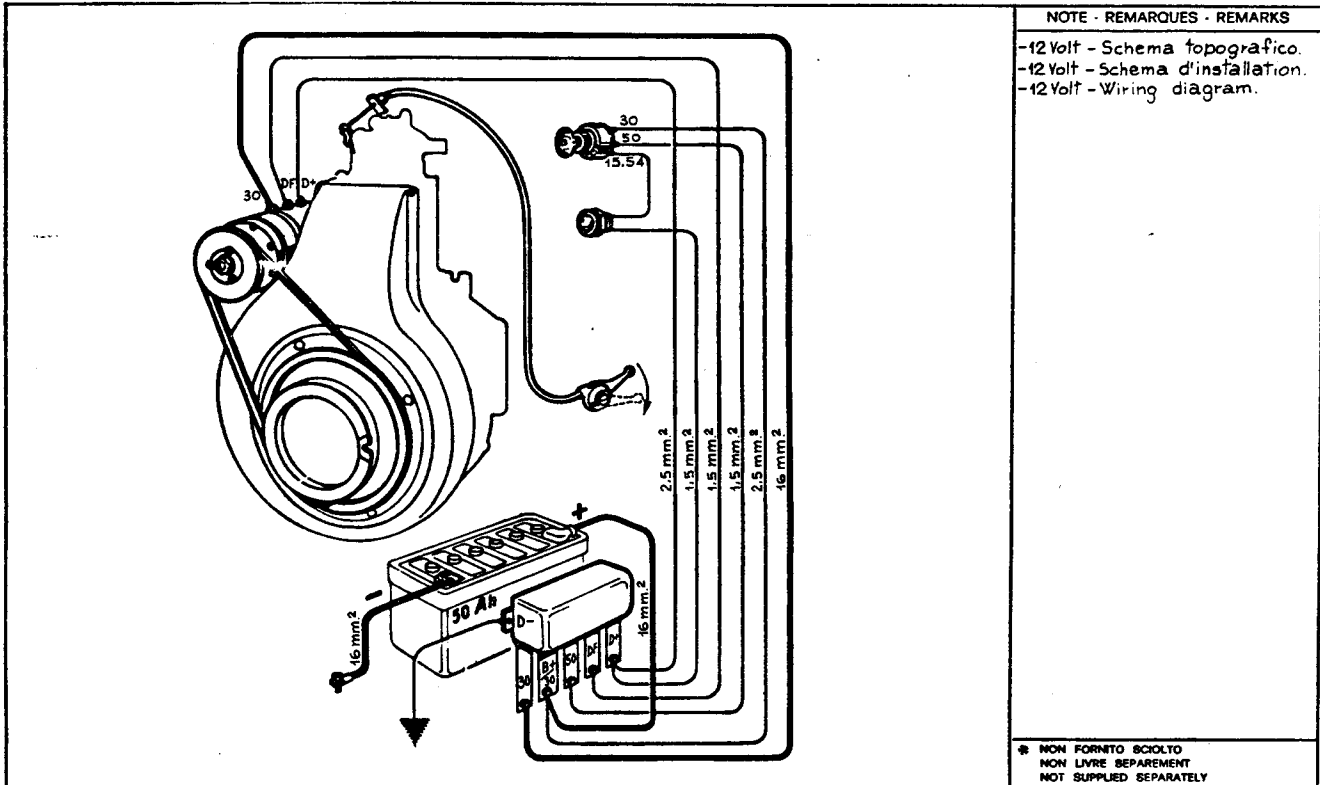

NOTE - REMARQUES - REMARKS
 -12 Volt - Schema topografico.
 -12 Volt - Schema d'installation.
 -12 Volt - Wiring diagram.

* NON FORNITO SCIOLTO
 NON LIVRE SEPAREMENT
 NOT SUPPLIED SEPARATELY

COMPLESSIVO - GROUPE - ASSEMBLY		AVVIAMENTO ELETTRICO CON DINAMOTORE DEMARRAGE ELECTRIQUE AVEC DYNASTART ELECTRICAL STARTING WITH STARTER GENERATOR	TAVOLA TABLE	4	61	4
MOTORE O VERSIONE MOTEUR OU ADAPTATION ENGINE OR VERSION	LDA96-97-LDAM 96		FOGLIO FEUILLE PAGE			
			DATA DATE	2 - 73		

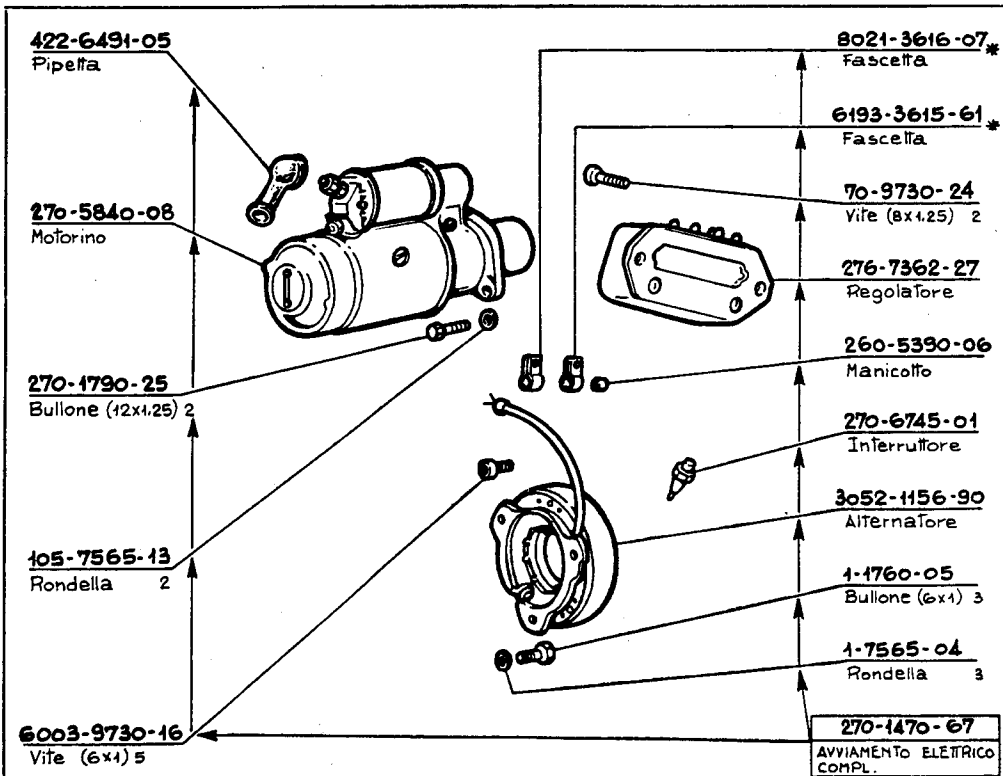

NOTE - REMARQUES - REMARKS
 -Alternatore 190w; regolatore a diodi controllati, per motori non predisposti.
 -Alternateur 190w; régulateur transistorisé, pour moteurs non prédisp.
 -190 w alternator; transistorized voltage regulator, for engines not adapted.

* NON FORNITO SCIOLTO
 NON LIVRE SEPAREMENT
 NOT SUPPLIED SEPARATELY

COMPLESSIVO - GROUPE - ASSEMBLY		AVVIAMENTO ELETTRICO CON MOTORINO DEMARRAGE ELECTRIQUE AVEC DEMARREUR ELECTRICAL STARTING WITH MOTOR	TAVOLA TABLE	4	61	5
MOTORE O VERSIONE MOTEUR OU ADAPTATION ENGINE OR VERSION	LDA96-97-LDAM 96 (K.9984.74)		FOGLIO FEUILLE PAGE	1	2	
			DATA DATE	2 - 73		



270-2940-70
Curva scarico

270-4775-39
Guarnizione

270-3240-53
Dado (40x1.5) 2

291-6371-39
Piastra

279-6800-59
Prigioniero (40x1.5)

236-6800-18
Prigioniero (40x1.5) 2

270-9881-28
VOLANO COMPL.

270-6800-50
Prigioniero (40x1.5) 2

202-7565-41
Rondella 2

270-2565-70
Convogliatore

271-7500-18
Rondella 7

260-1755-01
Bullone (5x0.8) 7

270-9881-06 *

270-2816-11
Corona

NOTE - REMARQUES - REMARKS
-Alternatore 190w; regolatore a diodi controllati, per motori non predisposti.
-Alternateur 190w; régulateur transistorisé, pour moteurs non prédisp.
-190w alternator; transistorized voltage regulator, for engines not adapted.

* NON FORNITO SCIOLTO
NON LIVRE SEPARÉMENT
NOT SUPPLIED SEPARATELY

COMPLESSIVO - GROUPE - ASSEMBLY		AVVIAMENTO ELETTRICO CON MOTORINO DEMARRAGE ELECTRIQUE AVEC DEMARREUR ELECTRICAL STARTING WITH MOTOR	TAVOLA TABLE	4	61	5
MOTORE O VERSIONE MOTEUR OU ADAPTATION ENGINE OR VERSION	LDA96-97-LDAM 96 (K. 9984.74)		FOGLIO FEUILLE PAGE	2	2	
			DATA DATE	2 - 73		

422-6491-05
Pipetta

270-5840-08
Motorino

270-1790-25
Bullone (12x1.25) 2

105-7565-13
Rondella 2

270-6745-01
Interruttore

999-9730-13
Vite (6x1) 5

270-1470-66
AVVIAMENTO ELETTRICO
COMPL.

8021-3616-07 *
Fascella

6193-3615-61 *
Fascella

276-9731-92
Vite (8x1.25) 2

276-7362-18
Regolatore

260-5390-06
Manicotto

3052-1156-54
Alternatore

1-1760-05
Bullone (6x1) 3

1-7565-04
Rondella 3

NOTE - REMARQUES - REMARKS
-Alternatore 130w; regolatore a diodi controllati, per motori non predisposti.
-Alternateur 130w; régulateur transistorisé, pour moteurs non prédisp.
-130w alternator; transistorized voltage regulator, for engines not adapted.

* NON FORNITO SCIOLTO
NON LIVRE SEPARÉMENT
NOT SUPPLIED SEPARATELY

COMPLESSIVO - GROUPE - ASSEMBLY		AVVIAMENTO ELETTRICO CON MOTORINO DEMARRAGE ELECTRIQUE AVEC DEMARREUR ELECTRICAL STARTING WITH MOTOR	TAVOLA TABLE	4	61	6
MOTORE O VERSIONE MOTEUR OU ADAPTATION ENGINE OR VERSION	LDA96-97-LDAM96 (K. 9977.78)		FOGLIO FEUILLE PAGE	1	2	
			DATA DATE	2 - 73		

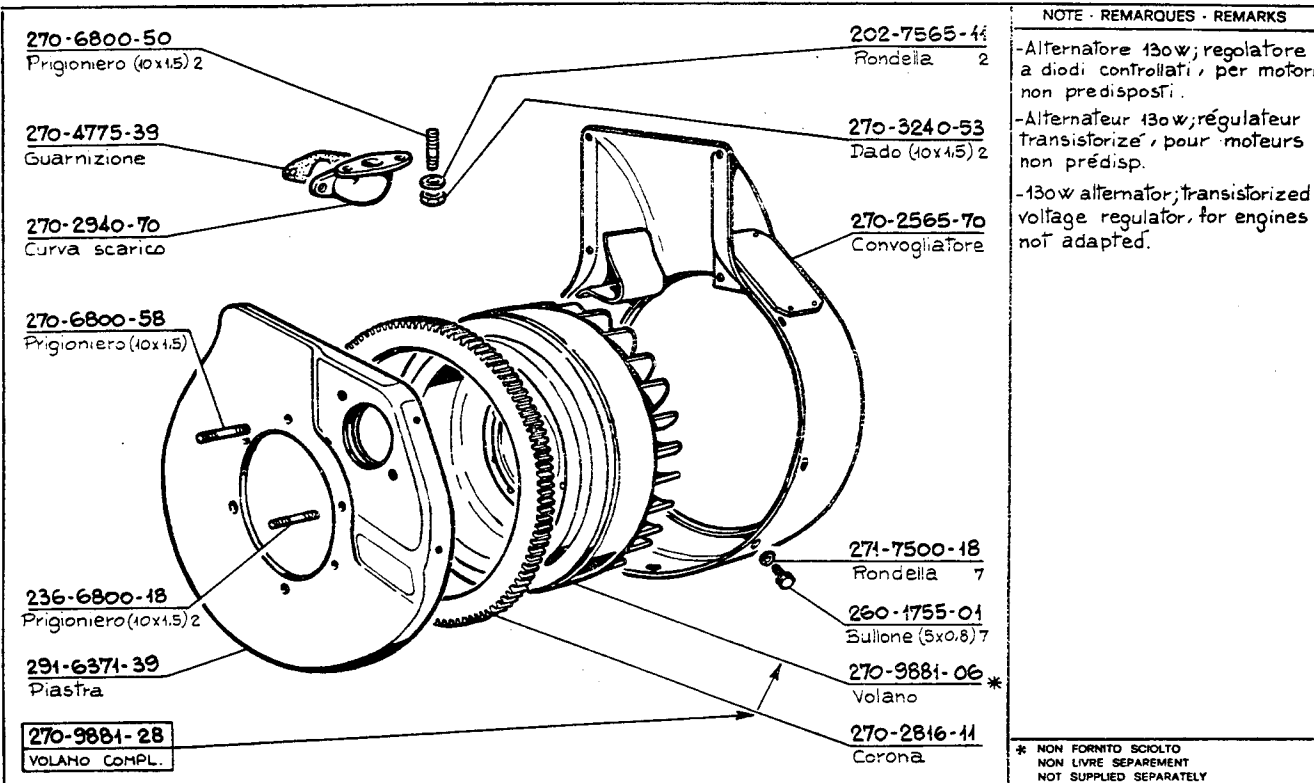

NOTE - REMARQUES - REMARKS

-Alternatore 130w; regolatore a diodi controllati, per motori non predisposti.

-Alternateur 130w; régulateur transistorisé, pour moteurs non prédisp.

-130w alternator; transistorized voltage regulator, for engines not adapted.

* NON FORNITO SCIOLTO
NON LIVRE SEPARÉMENT
NOT SUPPLIED SEPARATELY

COMPLESSIVO - GROUPE - ASSEMBLY		AVVIAMENTO ELETTRICO CON MOTORINO DEMARRAGE ELECTRIQUE AVEC DEMARREUR ELECTRICAL STARTING WITH MOTOR	TAVOLA TABLE	4	61	6
MOTORE O VERSIONE MOTEUR OU ADAPTATION ENGINE OR VERSION	LDA96-97-LDAM 96 (K. 9977.78)		FOGLIO FEUILLE PAGE	2	2	
			DATA DATE	2-73		

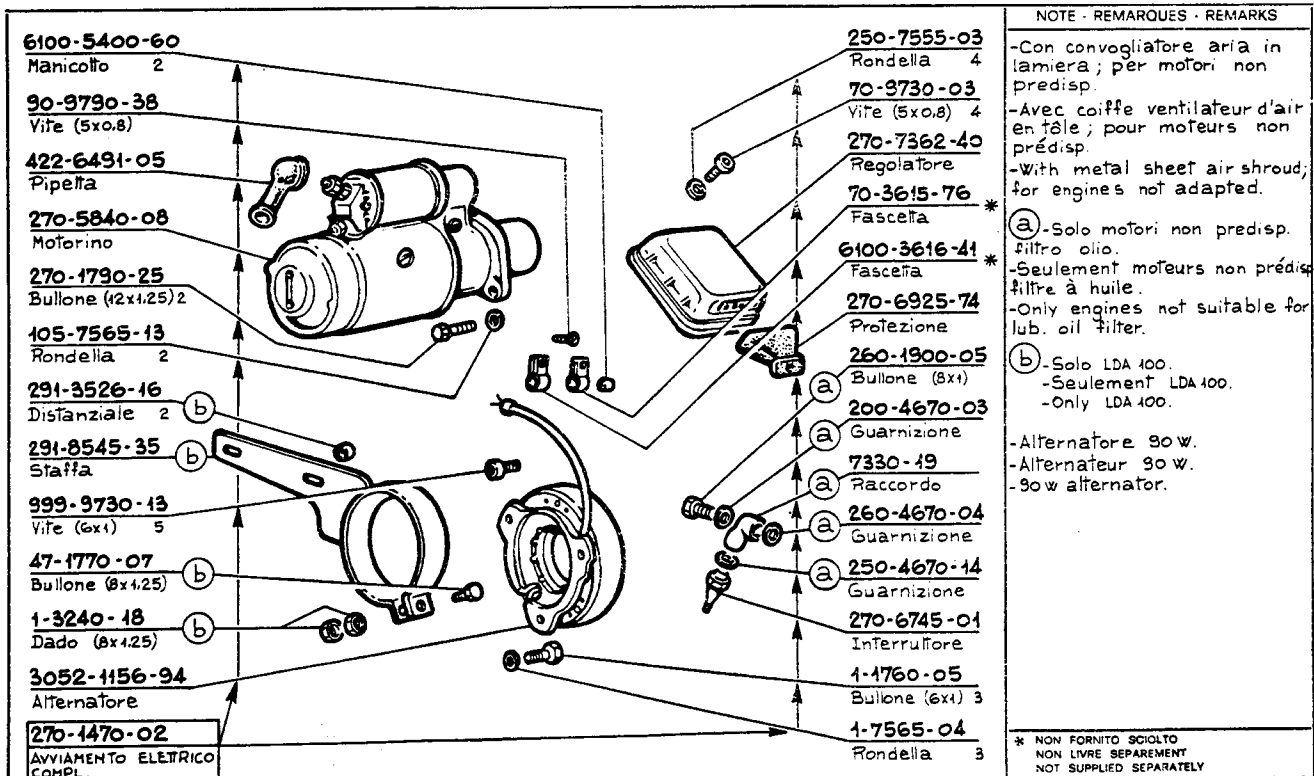

NOTE - REMARQUES - REMARKS

-Con convogliatore aria in lamiera; per motori non predisposti.

-Avec coiffe ventilateur d'air en tôle; pour moteurs non prédisp.

-With metal sheet air shroud; for engines not adapted.

(a) -Solo motori non predisposti. filtro olio.

-Seulement moteurs non prédisp. filtre à huile.

-Only engines not suitable for lub. oil filter.

(b) -Solo LDA 100.

-Seulement LDA 100.

-Only LDA 100.

-Alternatore 90w.

-Alternateur 90w.

-90w alternator.

* NON FORNITO SCIOLTO
NON LIVRE SEPARÉMENT
NOT SUPPLIED SEPARATELY

COMPLESSIVO - GROUPE - ASSEMBLY		AVVIAMENTO ELETTRICO CON MOTORINO DEMARRAGE ELECTRIQUE AVEC DEMARREUR ELECTRICAL STARTING WITH MOTOR	TAVOLA TABLE	4	61	7
MOTORE O VERSIONE MOTEUR OU ADAPTATION ENGINE OR VERSION	LDA96-97-100-LDAM96 (K. 9965.52-9983.62)		FOGLIO FEUILLE PAGE	1	2	
			DATA DATE	2-73		



CATALOGO GENERALE RICAMBI

NOTE - REMARQUES - REMARKS

- Con convogliatore aria in lamiera ; per motori non predisposti.
- Avec coiffe ventilateur d'air en tôle ; pour moteurs non predisposti.
- With metal sheet air shroud ; for engines not adapted.
- Alternatore 90 w.
- Alternateur 90 w.
- 90 w alternator.

*** NON FORNITO SCIOLTO
NON LIVRE SEPARÉMENT
NOT SUPPLIED SEPARATELY**

COMPLESSIVO - GROUPE - ASSEMBLY		TAVOLA TABLE	4	61	7
MOTORE O VERSIONE MOTEUR OU ADAPTATION ENGINE OR VERSION	LDA96-97-100-LDAM 96 (K.9965.52-9983.62)	AVVIAMENTO ELETTRICO CON MOTORINO DEMARRAGE ELECTRIQUE AVEC DEMARREUR ELECTRICAL STARTING WITH MOTOR	FOGLIO FEUILLE PAGE	2	2
			DATA DATE	2-73	

NOTE - REMARQUES - REMARKS

- Alternatore 190 w ; regolatore a diodi controllati, per motori predisposti.
- Alternateur 190 w ; régulateur transistorisé, pour moteurs predisposti.
- 190 w alternator ; transistorized voltage regulator, for engines adapted.

*** NON FORNITO SCIOLTO
NON LIVRE SEPARÉMENT
NOT SUPPLIED SEPARATELY**

COMPLESSIVO - GROUPE - ASSEMBLY		TAVOLA TABLE	4	61	8
MOTORE O VERSIONE MOTEUR OU ADAPTATION ENGINE OR VERSION	LDA 100 (K.9984.75)	AVVIAMENTO ELETTRICO CON MOTORINO DEMARRAGE ELECTRIQUE AVEC DEMARREUR ELECTRICAL STARTING WITH MOTOR	FOGLIO FEUILLE PAGE		
			DATA DATE	2-73	



270-6745-01
Interruttore

422-6491-05
Pipetta

270-5840-08
Motorino

270-1790-25
Bullone (12x1.25) 2

105-7565-13
Rondella 2

90-9790-38
Vite (5x0.8)

***6100-3616-41**
Fascetta

291-3526-16
Distanziale 2

291-8545-35
Staffa

999-9730-13
Vite (6x1) 5

1-3240-18
Dado (8x1.25)

47-1770-07
Bullone (8x1.25)

270-1470-02
AVVIAMENTO ELETTRICO
COMPL.

250-7555-03
Rondella 4

70-9730-03
Vite (5x0.8) 4

270-7362-40
Regolatore

70-3615-76*
Fascetta

6100-5400-60
Manicotto

270-6925-74
Protezione

3052-1156-34
Alternatore

270-4775-39
Guarnizione

270-2940-70
Curva scarico

270-6800-50
Prigioniero (10x1.5) 2

202-7565-11
Rondella 2

270-3240-53
Dado (10x1.5) 2

1-1760-05
Bullone (6x1) 3

1-7565-04
Rondella 3

NOTE - REMARQUES - REMARKS

- Con convogliatore aria in lamiera; per motori LDA 100 predisposti e LDA 820 con decompressione.
- Avec coiffe ventilateur d'air en tôle; pour moteurs LDA 100 prédisp. et LDA 820 avec décompression.
- With metal sheet air shroud; for engines LDA 100 suitable for el. start. and LDA 820 with compr. release.
- (a) -Solo LDA 100.
- Seulement LDA 100.
- Only LDA 100.
- Per i motori LDA 820 senza decompressione fornire gr. Tav. 4-37-1.
- Pour les moteurs LDA 820 sans décompression livrer groupe Table 4-37-1.
- For engines LDA 820 without compr. release supply ass'y of table 4-37-1.

* NON FORNITO SCIOLTO
NON LIVRE SEPARÉMENT
NOT SUPPLIED SEPARATELY

COMPLESSIVO - GROUPE - ASSEMBLY		TAVOLA TABLE	4	61	9
MOTORE O VERSIONE MOTEUR OU ADAPTATION ENGINE OR VERSION	LDA 100-820 (K.9967.56-9979.76)	FOGLIO FEUILLE PAGE			
		DATA DATE	2-73		

**AVVIAMENTO ELETTRICO CON MOTORINO
DEMARRAGE ELECTRIQUE AVEC DEMARREUR
ELECTRICAL STARTING WITH MOTOR**

***8021-3616-07**
Fascetta

422-6491-05
Pipetta

270-5840-08
Motorino

270-1790-25
Bullone (12x1.25) 2

105-7565-13
Rondella 2

999-9730-13
Vite (6x1) 5

291-3526-16
Distanziale 2

291-8545-35
Staffa

1-3240-18
Dado (8x1.25)

47-1770-07
Bullone (8x1.25)

270-1470-06
AVVIAMENTO ELETTRICO
COMPL.

276-9731-92
Vite (8x1.25) 2

276-7362-18
Regolatore

270-6745-01
Interruttore

3052-1156-54
Alternatore

270-4775-39
Guarnizione

270-2940-70
Curva scarico

270-6800-50
Prigioniero (10x1.5) 2

202-7565-11
Rondella 2

270-3240-53
Dado (10x1.5) 2

1-1760-05
Bullone (6x1) 3

1-7565-04
Rondella 3

NOTE - REMARQUES - REMARKS

- Regolatore a diodi controllati; per motori LDA 100 predisposti e LDA 820 con decompressione.
- Régulateur transistorisé; pour moteurs LDA 100 prédisp. et LDA 820 avec décompression.
- Transistorized voltage regulator; for engines LDA 100 suitable for el. start. and LDA 820 with compr. release.
- (a) -Solo LDA 100.
- Seulement LDA 100.
- Only LDA 100.
- Per i motori LDA 820 senza decompressione fornire gr. Tav. 4-37-1.
- Pour les moteurs LDA 820 sans décompression livrer groupe Table 4-37-1.
- For engines LDA 820 without compr. release supply ass'y of Table 4-37-1.
- Alternatore 130w.
- Alternateur 130w.
- 130w alternator.

* NON FORNITO SCIOLTO
NON LIVRE SEPARÉMENT
NOT SUPPLIED SEPARATELY

COMPLESSIVO - GROUPE - ASSEMBLY		TAVOLA TABLE	4	61	10
MOTORE O VERSIONE MOTEUR OU ADAPTATION ENGINE OR VERSION	LDA 100-820 (K.9977.79-9980.03)	FOGLIO FEUILLE PAGE			
		DATA DATE	2-73		

**AVVIAMENTO ELETTRICO CON MOTORINO
DEMARRAGE ELECTRIQUE AVEC DEMARREUR
ELECTRICAL STARTING WITH MOTOR**



<p>422-6491-05 Pipetta</p> <p>270-5840-08 Motorino</p> <p>270-1790-25 Bullone (2x125) 2</p> <p>105-7565-13 Rondella 2</p> <p>291-3526-16 Distanziale 2</p> <p>291-8545-35 Staffa</p> <p>1-3240-18 Dado (8x125)</p> <p>47-1770-07 Bullone (8x125)</p> <p>291-1470-68 AVVIAMENTO ELETTRICO COMPL.</p>		<p>70-9730-24 Vite (8x125) 2</p> <p>276-6740-19 Presa multipla</p> <p>276-2145-06 Cappuccio</p> <p>276-7362-26 Regolatore</p> <p>8021-3616-07 Fascella *</p> <p>6003-9730-16 Vite (6x1) 5</p> <p>270-6745-01 Interruttore</p> <p>3052-1156-90 Alternatore</p> <p>1-1760-05 Bullone (6x1) 3</p> <p>1-7565-04 Rondella 3</p>		<p>NOTE - REMARQUES - REMARKS</p> <p>-Alternatore 190w; regolatore a diodi controllati e spia carica batteria.</p> <p>-Alternateur 190w; régulateur transistorisé et témoin charge batt.</p> <p>-190 w alternator; transistorized voltage regulator and battery charge warning light.</p> <p>-Per i motori LDA 820 senza decompressione fornire gr. Tav. 4-37-1.</p> <p>-Pour les moteurs LDA820 sans décompression livrer groupe Table 4-37-1.</p> <p>-For engines LDA 820 without compr. release supply assy of Table 4-37-1.</p> <p>* NON FORNITO SCOLTO NON LIVRE SEPARÉMENT NOT SUPPLIED SEPARATELY</p>	
<p>COMPLESSIVO - GROUPE - ASSEMBLY</p>		<p>AVVIAMENTO ELETTRICO CON MOTORINO DEMARRAGE ELECTRIQUE AVEC DEMARREUR ELECTRICAL STARTING WITH MOTOR</p>		<p>TAVOLA TABLE</p> <p>FOGLIO FEUILLE PAGE</p> <p>DATA DATE</p>	<p>4 61 11</p> <p>2-73</p>
<p>MOTORE O VERSIONE MOTEUR OU ADAPTATION ENGINE OR VERSION</p>		<p>LDA 820 (K. 9985.28)</p>			

		<p>NOTE - REMARQUES - REMARKS</p> <p>-Schema topografico. -Schema d'installation. -Wiring diagram.</p> <p>* NON FORNITO SCOLTO NON LIVRE SEPARÉMENT NOT SUPPLIED SEPARATELY</p>			
<p>COMPLESSIVO - GROUPE - ASSEMBLY</p>		<p>AVVIAMENTO ELETTRICO CON MOTORINO DEMARRAGE ELECTRIQUE AVEC DEMARREUR ELECTRICAL STARTING WITH MOTOR</p>		<p>TAVOLA TABLE</p> <p>FOGLIO FEUILLE PAGE</p> <p>DATA DATE</p>	<p>4 61 12</p> <p>2-73</p>
<p>MOTORE O VERSIONE MOTEUR OU ADAPTATION ENGINE OR VERSION</p>					

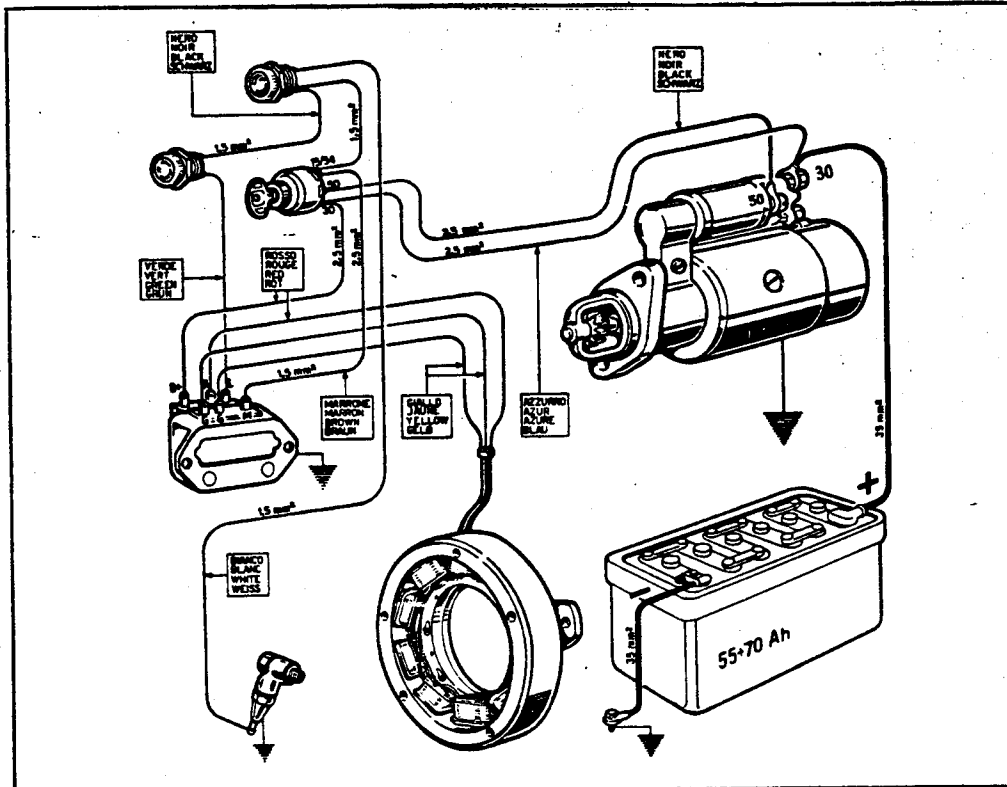

NOTE - REMARQUES - REMARKS

- Schema topografico.
- Schema d'installation.
- Wiring diagram.
- Con spia carica batteria.
- Avec témoin charge batterie.
- Battery charging warning light.

* NON FORNITO SCOLTO
NON LIVRE SEPARÉMENT
NOT SUPPLIED SEPARATELY

COMPLESSIVO - GROUPE - ASSEMBLY	AVVIAMENTO ELETTRICO CON MOTORINO DEMARRAGE ELECTRIQUE AVEC DEMARREUR ELECTRICAL STARTING WITH MOTOR	TAVOLA TABLE	4	61	13
MOTORE O VERSIONE MOTEUR OU ADAPTATION ENGINE OR VERSION		FOGLIO FEUILLE PAGE			
		DATA DATE	2 - 73		

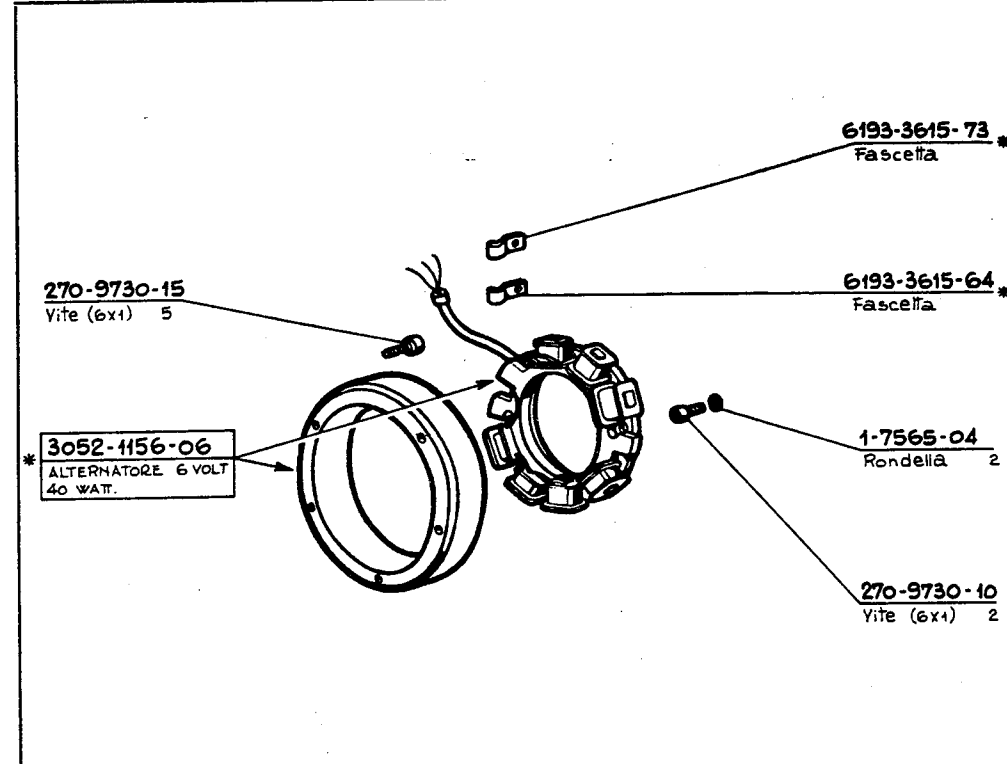

NOTE - REMARQUES - REMARKS

- 6 Volt, 40w; Senza ricarica batteria.
- 6 Volt, 40w; sans charge de la batterie.
- 6 Volt, 40w; without battery recharging.

* NON FORNITO SCOLTO
NON LIVRE SEPARÉMENT
NOT SUPPLIED SEPARATELY

COMPLESSIVO - GROUPE - ASSEMBLY	270-1156-19	ALTERNATORE LUCE ALTERNATEUR LUMIERE LIGHTING ALTERNATOR	TAVOLA TABLE	4	62	1
MOTORE O VERSIONE MOTEUR OU ADAPTATION ENGINE OR VERSION	(K. 9965.30)		FOGLIO FEUILLE PAGE			
			DATA DATE	2 - 73		



CATALOGO GENERALE RICAMBI

		<p>NOTE - REMARQUES - REMARKS</p> <p>-6 Volt, 40w; con ricarica batteria.</p> <p>-6 Volt, 40w; avec charge de la batterie.</p> <p>-6 Volt, 40w; with battery recharging.</p>														
		<p>* NON FORNITO SCIOLTO NON LIVRE SEPARÉMENT NOT SUPPLIED SEPARATELY</p>														
<p>COMPLESSIVO - GROUPE - ASSEMBLY 270-1156-20</p>		<p>ALTERNATORE LUCE ALTERNATEUR LUMIERE LIGHTING ALTERNATOR</p>		<table border="1" style="width: 100%; border-collapse: collapse;"> <tr> <td>TAVOLA TABLE</td> <td style="text-align: center;">4</td> <td style="text-align: center;">62</td> <td style="text-align: center;">2</td> </tr> <tr> <td>FOGLIO FEUILLE PAGE</td> <td></td> <td></td> <td></td> </tr> <tr> <td>DATA DATE</td> <td colspan="3" style="text-align: center;">2 - 73</td> </tr> </table>	TAVOLA TABLE	4	62	2	FOGLIO FEUILLE PAGE				DATA DATE	2 - 73		
TAVOLA TABLE	4	62	2													
FOGLIO FEUILLE PAGE																
DATA DATE	2 - 73															
<p>MOTORE O VERSIONE MOTEUR OU ADAPTATION ENGINE OR VERSION</p>	<p>(K. 9965.31)</p>															

		<p>NOTE - REMARQUES - REMARKS</p> <p>-12 Volt, 130 W; con regolatore a diodi controllati.</p> <p>-12 Volt, 130w; avec regulateur transistorize.</p> <p>-12 Volt, 130w; with transistorized regulator.</p>														
		<p>* NON FORNITO SCIOLTO NON LIVRE SEPARÉMENT NOT SUPPLIED SEPARATELY</p>														
<p>COMPLESSIVO - GROUPE - ASSEMBLY 270-1156-20</p>		<p>ALTERNATORE LUCE ALTERNATEUR LUMIERE LIGHTING ALTERNATOR</p>		<table border="1" style="width: 100%; border-collapse: collapse;"> <tr> <td>TAVOLA TABLE</td> <td style="text-align: center;">4</td> <td style="text-align: center;">62</td> <td style="text-align: center;">3</td> </tr> <tr> <td>FOGLIO FEUILLE PAGE</td> <td></td> <td></td> <td></td> </tr> <tr> <td>DATA DATE</td> <td colspan="3" style="text-align: center;">2 - 73</td> </tr> </table>	TAVOLA TABLE	4	62	3	FOGLIO FEUILLE PAGE				DATA DATE	2 - 73		
TAVOLA TABLE	4	62	3													
FOGLIO FEUILLE PAGE																
DATA DATE	2 - 73															
<p>MOTORE O VERSIONE MOTEUR OU ADAPTATION ENGINE OR VERSION</p>	<p>(K. 9968.54)</p>															

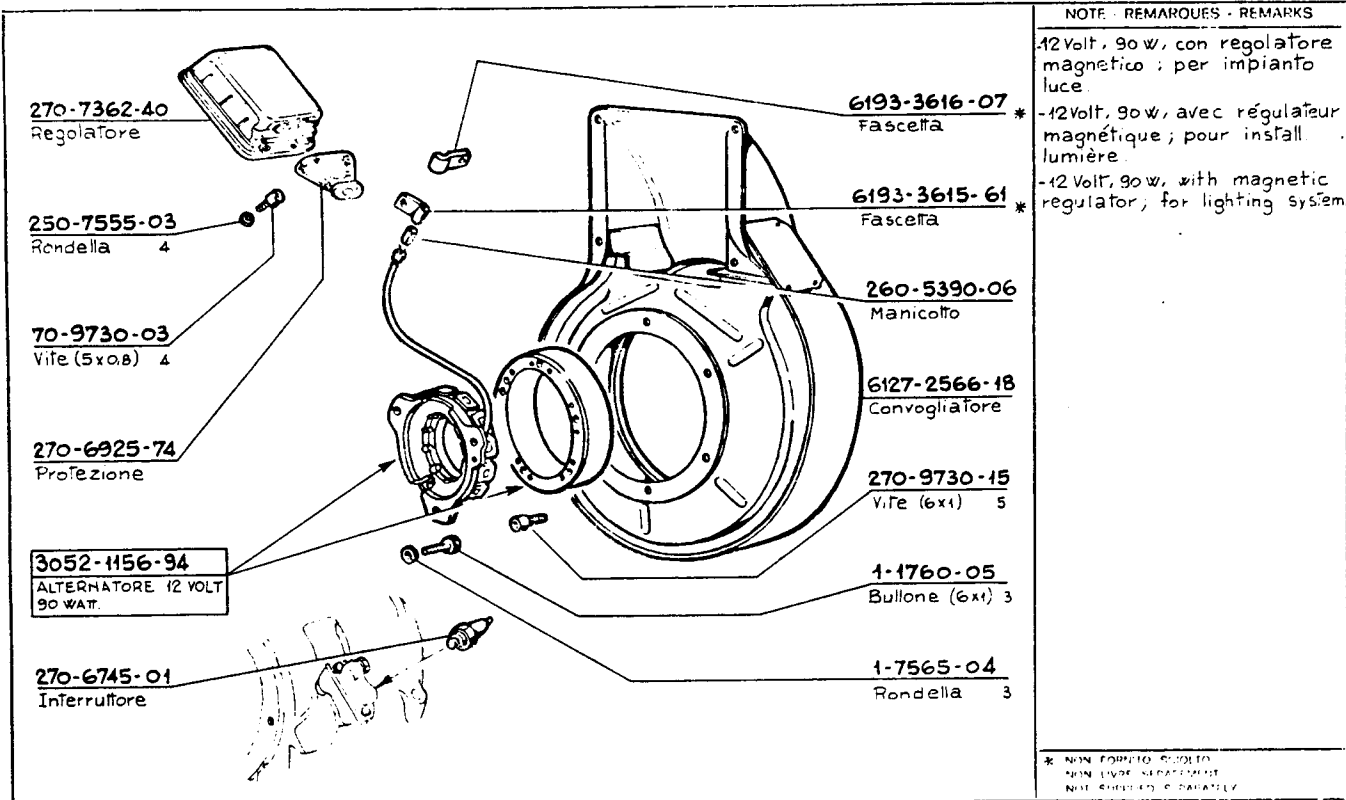

NOTE - REMARQUES - REMARKS

-12 Volt, 90 w, con regolatore magnetico; per impianto luce.
-12 Volt, 90 w, avec régulateur magnétique; pour install. lumière
-12 Volt, 90 w, with magnetic regulator; for lighting system.

* NON FORNITO SCIOLTO
NON LIVRE SEPARATEMENT
NOT SUPPLIED SEPARATELY

COMPLESSIVO - GROUPE - ASSEMBLY		ALTERNATORE LUCE ALTERNATEUR LUMIERE LIGHTING ALTERNATOR	TAVOLA TABLE	4	62	4
MOTORE O VERSIONE MOTEUR OU ADAPTATION ENGINE OR VERSION	LDA 96-97-LDAM 96 (K.9977.88)		FOGLIO FEUILLE PAGE			
			DATA DATE	2-73		

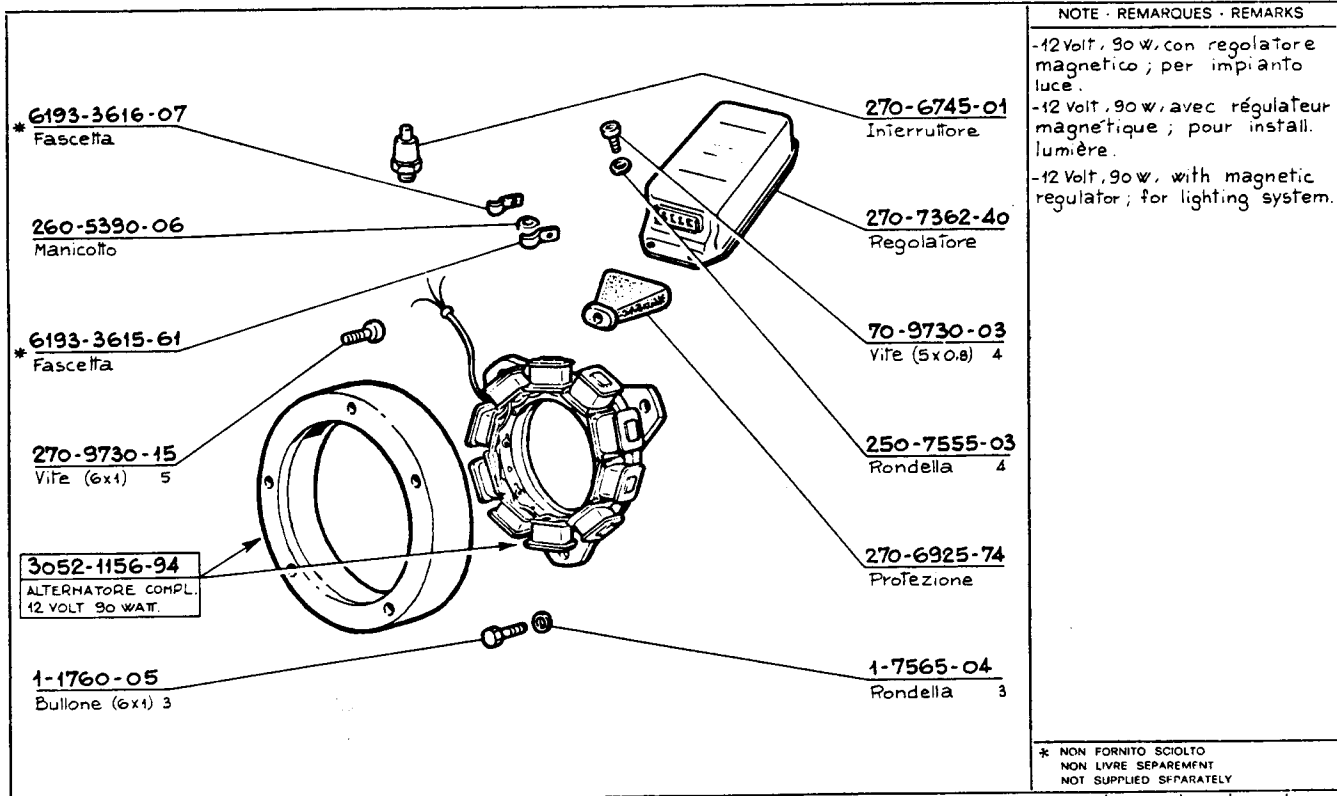

NOTE - REMARQUES - REMARKS

-12 Volt, 90 w, con regolatore magnetico; per impianto luce.
-12 Volt, 90 w, avec régulateur magnétique; pour install. lumière.
-12 Volt, 90 w, with magnetic regulator; for lighting system.

* NON FORNITO SCIOLTO
NON LIVRE SEPARATEMENT
NOT SUPPLIED SEPARATELY

COMPLESSIVO - GROUPE - ASSEMBLY		ALTERNATORE LUCE ALTERNATEUR LUMIERE LIGHTING ALTERNATOR	TAVOLA TABLE	4	62	5
MOTORE O VERSIONE MOTEUR OU ADAPTATION ENGINE OR VERSION	LDA 100-820 (K.9977.87)		FOGLIO FEUILLE PAGE			
			DATA DATE	2-73		



NOTE - REMARQUES - REMARKS

-Schema topografico.
-Schema d'installazione.
-Wiring diagram.

● -Cavi da isolare.
-Cables à isoler.
-Cables to be insulated.

* NON FORNITO SCIOLTO
NON LIVRE SEPARÉMENT
NOT SUPPLIED SEPARATELY

COMPLESSIVO · GROUPE · ASSEMBLY		TAVOLA TABLE	4	62	6
MOTORE O VERSIONE MOTEUR OU ADAPTATION ENGINE OR VERSION	IMPIANTO LUCE SENZA RICARICA BATTERIA INSTALL. LUMIERE SANS RECHARGE DE LA BATT. LIGHTING SYSTEM WITHOUT BATTERY RECHAR.	FOGLIO FEUILLE PAGE			
		DATA DATE	2 - 73		

NOTE - REMARQUES - REMARKS

-Schema topografico.
-Schema d'installazione.
-Wiring diagram.

* NON FORNITO SCIOLTO
NON LIVRE SEPARÉMENT
NOT SUPPLIED SEPARATELY

COMPLESSIVO · GROUPE · ASSEMBLY		TAVOLA TABLE	4	62	7
MOTORE O VERSIONE MOTEUR OU ADAPTATION ENGINE OR VERSION	IMPIANTO LUCE CON RICARICA BATTERIA INSTALL. LUMIERE AVEC RECHARGE DE LA BATT. LIGHTING SYSTEM WITH BATTERY RECHARGING	FOGLIO FEUILLE PAGE			
		DATA DATE	2 - 73		



2750-21
Coperchio

260-4165-06
Anello Benzing

1-7565-04
Rondella 2

270-9800-03
Vite (5x0.8) 2

5660-14
Molla

5110-88
Lamiera

23-6780-09
Bullone (5x0.8)

26-7565-03
Rondella

23-6780-09
Bullone (5x0.8) 2

225-3240-04
Dado (5x0.8) 2

1-7565-04
Rondella

30-9790-03
Vite (4x0.7)

45-6000-16
Pastiglia

5200-24
Leva

2500-33
Colonna

8615-21
Supporto

270-4700-69*
Guarnizione

270-5200-05
Leva

3-8420-03
Spina

270-6140-39
Perno

3-9800-10
Vite (6x1) 3

NOTE - REMARQUES - REMARKS
-Fino a } LDA 96 N° 497643
-Jusqu'au } LDA 97 N° 505953
-Below }

* NON FORNITO SCOLTO
NON LIVRE SEPARÉMENT
NOT SUPPLIED SEPARATELY

COMPLESSIVO - GROUPE - ASSEMBLY		TAVOLA TABLE	4	64	1
MOTORE O VERSIONE MOTEUR OU ADAPTATION ENGINE OR VERSION	LDA 96-97	FOGLIO FEUILLE PAGE			
		DATA DATE	2 - 73		

COMANDO ACCELERATORE A DISTANZA
COMMANDE D'ACCELERATION A DISTANCE
REMOTE THROTTLE CONTROL

270-2690-42
Coperchio

45-6000-16
Pastiglia

30-9790-03
Vite (4x0.7)

105-4760-01
Bullone (6x1) 2

250-7555-04
Rondella

70-9180-11
Terminale (a)

70-9180-47
Terminale (b)

308-3240-09
Dado (6x1) (a)

3-3240-19
Dado (8x1.25) (b)

270-7065-18
Scatola (c)

270-9820-73
Vite

270-5200-86
Leva

270-9245-31
Tirante

270-6141-16
Perno

270-5680-25
Molla

270-1760-28
Bullone (6x1)

105-3240-08
Dado (6x1)

270-1760-29
Bullone (6x1)

105-3240-08
Dado (6x1)

270-5200-05
Leva

209-8420-12
Spina

NOTE - REMARQUES - REMARKS
-Da } LDA 96 N° 497644
-A partir de } LDA 97 N° 505954
-Starting from }
(a) -Fino a } LDA 96 N° 778656
-Jusqu'au } LDA 97 N° 779625
-Below } LDA 100 N° 790071
LDA 820 N° 801100
(b) -Da } LDA 96 N° 778657
-A partir de } LDA 97 N° 779626
-Starting from } LDA 100 N° 790072
LDA 820 N° 801101
(c) -Per i motori al punto (b),
oltre alla scatola, fornire il
terminale 70-9180-47 e il dado
3-3240-19.
-Pour les moteurs (b), fournir
la boîte avec arrêt 70-9180-47
et écrou 3-3240-19.
-For engines (b), beside box,
supply cable end 70-9180-47
and nut 3-3240-19.

* NON FORNITO SCOLTO
NON LIVRE SEPARÉMENT
NOT SUPPLIED SEPARATELY

COMPLESSIVO - GROUPE - ASSEMBLY	270-2515-26	TAVOLA TABLE	4	64	2
MOTORE O VERSIONE MOTEUR OU ADAPTATION ENGINE OR VERSION	LDA 96-97-100-820	FOGLIO FEUILLE PAGE			
		DATA DATE	2 - 73		

COMANDO ACCELERATORE A DISTANZA
COMMANDE D'ACCELERATION A DISTANCE
REMOTE THROTTLE CONTROL



CATALOGO GENERALE RICAMBI

<p>205-2800-09 Copiglia</p> <p>260-3283-04 Dado (8x125)</p> <p>270-7625-02 Rondella 2</p> <p>200-2800-02 Copiglia 2</p> <p>270-9235-08 Tirante</p> <p>270-5200-13 Leva</p> <p>1-1760-05 Bullone (6x1) 2</p> <p>1-7565-04 Rondella 2</p>		<p>45-7625-12 Rondella</p> <p>270-6550-10 Pomello</p> <p>270-5200-44 Leva</p> <p>270-4775-28 Guarnizione</p> <p>270-6870-01 Prigioniero</p> <p>45-7625-12 Rondella</p> <p>270-7565-06 Rondella</p>	<p>NOTE - REMARQUES - REMARKS</p> <p>-Fino a } LDA 96 N° 497643 -Jusqu'au } LDA 97 N° 505953 -Below }</p> <p>* NON FORNITO SCIOLTO NON LIVRE SEPARMENT NOT SUPPLIED SEPARATELY</p>
<p>COMPLESSIVO - GROUPE - ASSEMBLY</p>		<p>COMANDO ACCELERATORE A MANO COMMANDE D'ACCELERATION A MAIN HAND THROTTLE CONTROL</p>	<p>TAVOLA TABLE 4 64 3</p> <p>FOGLIO FEUILLE PAGE</p> <p>DATA DATE 2-73</p>
<p>MOTORE O VERSIONE MOTEUR OU ADAPTATION ENGINE OR VERSION</p>	<p>LDA96-97</p>		

<p>270-7865-18 (c) Scatola</p> <p>105-1760-01 Bullone (6x1)</p> <p>276-1770-42 Bullone (8x125)</p> <p>1-7565-04 Rondella</p> <p>255-7555-07 Rondella</p> <p>3-9800-10 Vite (6x1) 3</p> <p>209-8420-12 Spina</p>		<p>105-3240-08 Dado (6x1)</p> <p>270-1760-28 Bullone (6x1)</p> <p>105-3240-08 Dado (6x1)</p> <p>270-1760-29 Bullone (6x1)</p> <p>270-5200-05 Leva</p> <p>270-4700-69* Guarnizione</p>	<p>NOTE - REMARQUES - REMARKS</p> <p>-Da } LDA 96 N° 497644 -A partir de } LDA 97 N° 505954 -Starting from }</p> <p>(a) -Fino a } LDA 96 N° 778656 -Jusqu'au } LDA 97 N° 779625 -Below } LDA 100 N° 790071 LDA 820 N° 801101</p> <p>(b) -Da } LDA 96 N° 778657 -A partir de } LDA 97 N° 779626 -Starting from } LDA 100 N° 790072 LDA 820 N° 801102</p> <p>(c) -Per i motori al punto (b) oltre alla scatola fornire il bullone 276-1770-42. -Pour les moteurs (b) livrer le boulon 276-1770-42. -For engines (b) supply bolt 276-1770-42.</p> <p>* NON FORNITO SCIOLTO NON LIVRE SEPARMENT NOT SUPPLIED SEPARATELY</p>
<p>COMPLESSIVO - GROUPE - ASSEMBLY</p>		<p>COMANDO ACCELERATORE A MANO COMMANDE D'ACCELERATION A MAIN HAND THROTTLE CONTROL</p>	<p>TAVOLA TABLE 4 64 4</p> <p>FOGLIO FEUILLE PAGE 1 2</p> <p>DATA DATE 2-73</p>
<p>MOTORE O VERSIONE MOTEUR OU ADAPTATION ENGINE OR VERSION</p>	<p>LDA96-97-100-820</p>		



CATALOGO GENERALE RICAMBI

NOTE - REMARQUES - REMARKS

-Da
-A partir de
-Starting from

LDA 96 N° 497644
LDA 97 N° 505954

* NON FORNITO SCIOLTO
NON LIVRE SEPARÉMENT
NOT SUPPLIED SEPARATELY

COMPLESSIVO - GROUPE - ASSEMBLY	270-2515-28	COMANDO ACCELERATORE A MANO COMMANDE D'ACCELERATION A MAIN HAND THROTTLE CONTROL	TAVOLA TABLE	4	64	4
MOTORE O VERSIONE MOTEUR OU ADAPTATION ENGINE OR VERSION	LDA 96-97-100-820		FUOGGIO FEUILLE PAGE	2	2	
			DATA DATE	2-73		

NOTE - REMARQUES - REMARKS

-Motore marino con invertitore-riduttore R.1:2.
-Moteur marin avec inverseur-réducteur R.1:2.
-Marine engine with reverse-reduction gear R.1:2.

-Vedi anche Tav. }
-Voir aussi Table } 4-71-1
-See also Table }

* NON FORNITO SCIOLTO
NON LIVRE SEPARÉMENT
NOT SUPPLIED SEPARATELY

COMPLESSIVO - GROUPE - ASSEMBLY		COMANDO ACCELERATORE A DISTANZA COMMANDE D'ACCELERATION A DISTANCE REMOTE THROTTLE CONTROL	TAVOLA TABLE	4	64	5
MOTORE O VERSIONE MOTEUR OU ADAPTATION ENGINE OR VERSION	LDAM 96 (K.9981.86)		FUOGGIO FEUILLE PAGE			
			DATA DATE	2-73		



		<p>NOTE - REMARQUES - REMARKS</p> <p>-Da } LDA 96 N°497644 -A partir de } LDA 97 N°505954 -Starting from } -Disinserzione automatica. -Déclanchement automatique -Automatic release.</p>
<p>* NON FORNITO SCIOLTO NON LIVRE SEPARÉMENT NOT SUPPLIED SEPARATELY</p>		<p>TAVOLA TABLE 4 64 6</p> <p>FOGLIO FEUILLE PAGE</p> <p>DATA DATE 2-73</p>
<p>COMPLESSIVO - GROUPE - ASSEMBLY</p>		<p>COMANDO ACCELERATORE A DISTANZA COMMANDE D'ACCELERATION A DISTANCE REMOTE THROTTLE CONTROL</p>
<p>MOTORE O VERSIONE MOTEUR OU ADAPTATION ENGINE OR VERSION</p>	<p>LDA96-97-100-820 (K.9965.71)</p>	

		<p>NOTE - REMARQUES - REMARKS</p> <p>-Da } LDA 96 N°497644 -A partir de } LDA 97 N°505954 -Starting from } -Con elettromagnete, per motore industriale. -Par electro-aimant, pour moteur industriel. -With magnetic switch, for industrial engine.</p>
<p>* NON FORNITO SCIOLTO NON LIVRE SEPARÉMENT NOT SUPPLIED SEPARATELY</p>		<p>TAVOLA TABLE 4 64 7</p> <p>FOGLIO FEUILLE PAGE</p> <p>DATA DATE 2-73</p>
<p>COMPLESSIVO - GROUPE - ASSEMBLY</p>		<p>COMANDO ACCELERATORE A DISTANZA COMMANDE D'ACCELERATION A DISTANCE REMOTE THROTTLE CONTROL</p>
<p>MOTORE O VERSIONE MOTEUR OU ADAPTATION ENGINE OR VERSION</p>	<p>LDA96-97-100-820 (K.9977.71)</p>	



CATALOGO GENERALE RICAMBI

		NOTE - REMARQUES - REMARKS	
		* NON FORNITO SCIOLTO NON LIVRE SEPARMENT NOT SUPPLIED SEPARATELY	
COMPLESSIVO - GROUPE - ASSEMBLY		TAVOLA TABLE	
MOTORE O VERSIONE MOTEUR OU ADAPTATION ENGINE OR VERSION		4 64 8	
LDA 96-97-100-820 (K.9968.05)		FOGLIO FEUILLE PAGE	
COMANDO ACCELERATORE A TACCHE COMMANDE D'ACCELERATION A CRANS NOTCH TYPE THROTTLE CONTROL		DATA DATE	
		2 - 73	

		NOTE - REMARQUES - REMARKS	
		* NON FORNITO SCIOLTO NON LIVRE SEPARMENT NOT SUPPLIED SEPARATELY	
COMPLESSIVO - GROUPE - ASSEMBLY		TAVOLA TABLE	
MOTORE O VERSIONE MOTEUR OU ADAPTATION ENGINE OR VERSION		4 65 1	
6121-2515-59 (K.9979.92)		FOGLIO FEUILLE PAGE	
COMANDO STOP A DISTANZA COMMANDE STOP A DISTANCE REMOTE STOP CONTROL		DATA DATE	
		2 - 73	



CATALOGO GENERALE RICAMBI

		<p>NOTE - REMARQUES - REMARKS</p>													
<p>7357-14 Registro 2</p>	<p>422-9730-28 Vite (8x1.25) 2</p>														
<p>225-3240-04 Dado (5x0.8) 2</p>	<p>5-7625-10 Rondella 2</p>														
<p>6330-5550-08 Molla 2</p>	<p>6121-6370-73 Piastra</p>														
<p>308-7375-05 Ribaltino</p>	<p>6121-5200-83 Levelta</p>														
<p>COMPLESSIVO - GROUPE - ASSEMBLY 6121-2515-73</p>		<p>* NON FORNITO SCIOLTO NON LIVRE SEPARMENT NOT SUPPLIED SEPARATELY</p>													
<p>MOTORE O VERSIONE MOTEUR OU ADAPTATION ENGINE OR VERSION</p>	<p>(K. 9966.18)</p>	<p>COM. STOP E SUPPL.TO COMBUST. A DISTANZA COMM. STOP ET SUPPL.COMBUST. A DISTANCE REMOTE STOP AND EXTRA FUEL CONTROL</p>	<table border="1"> <tr> <td>TAVOLA TABLE</td> <td>4</td> <td>65</td> <td>2</td> </tr> <tr> <td>FOGLIO FEUILLE PAGE</td> <td></td> <td></td> <td></td> </tr> <tr> <td>DATA DATE</td> <td colspan="3">2 - 73</td> </tr> </table>	TAVOLA TABLE	4	65	2	FOGLIO FEUILLE PAGE				DATA DATE	2 - 73		
TAVOLA TABLE	4	65	2												
FOGLIO FEUILLE PAGE															
DATA DATE	2 - 73														

		<p>NOTE - REMARQUES - REMARKS</p>													
<p>6121-6080-12 Perno</p>	<p>27-7625-05 Rondella 3</p>	<p>-Con elettromagnete. -Par electro-aimant. -With magnetic switch.</p>													
<p>1-2800-03 Copiglia 3</p>	<p>6121-3586-06 Elettromagnete</p>														
<p>1-2800-03 Copiglia 2</p>	<p>250-9790-10 Vite (5x0.8) 4</p>														
<p>6121-3586-04 Elettromagnete</p>	<p>6121-6371-22 Piastra</p>														
<p>250-9790-10 Vite (5x0.8) 4</p>	<p>422-9730-28 Vite (8x1.25) 2</p>														
<p>6121-8385-29 Spina</p>	<p>5-7625-10 Rondella 2</p>														
<p>27-7625-05 Rondella 2</p>	<p>6127-8901-60 Supporto</p>														
<p>COMPLESSIVO - GROUPE - ASSEMBLY 6121-2515-75</p>		<p>* NON FORNITO SCIOLTO NON LIVRE SEPARIMENT NOT SUPPLIED SEPARATELY</p>													
<p>MOTORE O VERSIONE MOTEUR OU ADAPTATION ENGINE OR VERSION</p>	<p>(K. 9977.93)</p>	<p>COM. STOP E SUPPL.TO COMBUST. A DISTANZA COMM. STOP ET SUPPL.COMBUST. A DISTANCE REMOTE STOP AND EXTRA FUEL CONTROL</p>	<table border="1"> <tr> <td>TAVOLA TABLE</td> <td>4</td> <td>65</td> <td>3</td> </tr> <tr> <td>FOGLIO FEUILLE PAGE</td> <td></td> <td></td> <td></td> </tr> <tr> <td>DATA DATE</td> <td colspan="3">2 - 73</td> </tr> </table>	TAVOLA TABLE	4	65	3	FOGLIO FEUILLE PAGE				DATA DATE	2 - 73		
TAVOLA TABLE	4	65	3												
FOGLIO FEUILLE PAGE															
DATA DATE	2 - 73														



		<p>NOTE - REMARQUES - REMARKS</p>												
<p>270-2030-90 Campana</p> <p>270-2050-60 Campana LDA 96-97-100.</p> <p>2050-24 Campana LDA 820</p> <p>264-8990-08 Tappo</p> <p>1860-92 Bullone LDA 96-97-100.</p> <p>6016-1862-13 Bullone LDA 820</p>	<p>270-4431-10 Guarnizione 0.10 *</p> <p>270-4431-04 Guarnizione 0.30 *</p> <p>270-1210-77 Anello Tenuta</p> <p>3-6800-04 Prigioniero (10x1.6)</p> <p>202-7565-11 Rondella 6</p> <p>3-3240-33 Dado (10x1.5) 6</p>													
<p>COMPLESSIVO - GROUPE - ASSEMBLY</p>														
<p>MOTORE O VERSIONE MOTEUR OU ADAPTATION ENGINE OR VERSION</p>	<p>LDA 96-97-100-820</p>	<p>FLANGIATURA STANDARD BRIDE STANDARD STANDARD FLANGE</p>												
		<table border="1" style="width: 100%; border-collapse: collapse;"> <tr> <td>TAVOLA TABLE</td> <td style="text-align: center;">4</td> <td style="text-align: center;">66</td> <td style="text-align: center;">1</td> </tr> <tr> <td>FOGLIO FEUILLE PAGE</td> <td></td> <td></td> <td></td> </tr> <tr> <td>DATA DATE</td> <td colspan="3" style="text-align: center;">2 - 73</td> </tr> </table>	TAVOLA TABLE	4	66	1	FOGLIO FEUILLE PAGE				DATA DATE	2 - 73		
TAVOLA TABLE	4	66	1											
FOGLIO FEUILLE PAGE														
DATA DATE	2 - 73													
		<p>* NON FORNITO SCIOLTO NON LIVRE SEPARMENT NOT SUPPLIED SEPARATELY</p>												

		<p>NOTE - REMARQUES - REMARKS</p>												
<p>270-2050-60 Campana</p> <p>1860-92 Bullone</p> <p>1-3240-18 Dado (8x1.25) 6</p>	<p>6016-2031-09 Campana</p> <p>25-6780-05 Prigioniero (8x1.25) 6</p> <p>1-7565-07 Rondella 6</p>													
<p>COMPLESSIVO - GROUPE - ASSEMBLY</p>														
<p>MOTORE O VERSIONE MOTEUR OU ADAPTATION ENGINE OR VERSION</p>	<p>LDA 96-100 (K. 9967.90)</p>	<p>FLANGIATURA STANDARD "B," BRIDE STANDARD "B," "B," STANDARD FLANGE</p>												
		<table border="1" style="width: 100%; border-collapse: collapse;"> <tr> <td>TAVOLA TABLE</td> <td style="text-align: center;">4</td> <td style="text-align: center;">66</td> <td style="text-align: center;">2</td> </tr> <tr> <td>FOGLIO FEUILLE PAGE</td> <td></td> <td></td> <td></td> </tr> <tr> <td>DATA DATE</td> <td colspan="3" style="text-align: center;">2 - 73</td> </tr> </table>	TAVOLA TABLE	4	66	2	FOGLIO FEUILLE PAGE				DATA DATE	2 - 73		
TAVOLA TABLE	4	66	2											
FOGLIO FEUILLE PAGE														
DATA DATE	2 - 73													
		<p>* NON FORNITO SCIOLTO NON LIVRE SEPARMENT NOT SUPPLIED SEPARATELY</p>												

-Versione industriale.
-Version industrielle.
-Industrial version.



		<p>NOTE - REMARQUES - REMARKS</p> <p>-Versione industriale. -Version industrielle. -Industrial version.</p>	
		<p>* NON FORNITO SCIOLTO NON LIVRE SEPARMENT NOT SUPPLIED SEPARATELY</p>	
<p>COMPLESSIVO - GROUPE - ASSEMBLY</p>		<p>TAVOLA TABLE</p> <p>4 66 3</p>	
<p>MOTORE O VERSIONE MOTEUR OU ADAPTATION ENGINE OR VERSION</p>	<p>LDA 820 (K. 9982.52)</p>	<p>FLANGIATURA STANDARD "B,, BRIDE STANDARD "B,, "B,, STANDARD FLANGE</p>	
		<p>FOGLIO FEUILLE PAGE</p>	
		<p>DATA DATE</p>	<p>2 - 73</p>

		<p>NOTE - REMARQUES - REMARKS</p> <p>-Versione industriale. -Version industrielle. -Industrial version.</p>	
		<p>* NON FORNITO SCIOLTO NON LIVRE SEPARMENT NOT SUPPLIED SEPARATELY</p>	
<p>COMPLESSIVO - GROUPE - ASSEMBLY</p>		<p>TAVOLA TABLE</p> <p>4 66 4</p>	
<p>MOTORE O VERSIONE MOTEUR OU ADAPTATION ENGINE OR VERSION</p>	<p>LDA 96-100 (K. 9967.89)</p>	<p>FLANGIATURA STANDARD "D,, BRIDE STANDARD "D,, "D,, STANDARD FLANGE</p>	
		<p>FOGLIO FEUILLE PAGE</p>	
		<p>DATA DATE</p>	<p>2 - 73</p>



CATALOGO GENERALE RICAMBI

6016-2050-99
Campana

6007-8400-46
Spina 3

6016-1862-13
Bullone

202-1770-02
Bullone (8x1.25) 6

5855-02
Mozzetto

6016-2031-08
Campana

25-6780-05
Prigioniero (8x1.25) 6

1-7565-07
Rondella 6

1-3240-18
Dado (8x1.25) 6

NOTE - REMARQUES - REMARKS

-Versione industriale.
-Version industrielle.
-Industrial Version.

* NON FORNITO SCOLTO
NON LIVRE SEPARÉMENT
NOT SUPPLIED SEPARATELY

COMPLESSIVO - GROUPE - ASSEMBLY		TAVOLA TABLE	4	66	5
MOTORE O VERSIONE MOTEUR OU ADAPTATION ENGINE OR VERSION	LDA 820 (K.9982.55)	FOGLIO FEUILLE PAGE			
	FLANGIATURA STANDARD "D," BRIDE STANDARD "D," "D," STANDARD FLANGE	DATA DATE	2-73		

6016-3900-91
Flangia

6241-4310-14
Grano 6

407-4220-04
Giunto

6016-3900-90
Flangia

6177-6220-13
Perno 3

6016-1861-65
Bullone

6016-2031-44
Campana

100-2800-16
Copiglia 3

3095-3206-24
Dado 3

6177-9265-51
Tirante 3

NOTE - REMARQUES - REMARKS

-Versione autotrazione.
-Version autotraction.
-Automotive version.

-Per alternatore LOM.
-Pour alternateur LOM.
-For LOM alternator.

* NON FORNITO SCOLTO
NON LIVRE SEPARÉMENT
NOT SUPPLIED SEPARATELY

COMPLESSIVO - GROUPE - ASSEMBLY		TAVOLA TABLE	4	66	6
MOTORE O VERSIONE MOTEUR OU ADAPTATION ENGINE OR VERSION	LDA 96 (K.9968.22)	FOGLIO FEUILLE PAGE			
	FLANGIATURA STANDARD BRIDE STANDARD STANDARD FLANGE	DATA DATE	2-73		



CATALOGO GENERALE RICAMBI

		<p>260-3240-01 Dado (3x0.5) 6</p> <p>260-7555-01 Rondella 6</p> <p>260-2870-04* Corpo</p> <p>260-5498-03 Membrana</p> <p>260-9810-01 Vite (3x0.5) 6</p> <p>260-2750-24 Coperchio</p> <p>260-5800-28 Molla</p> <p>260-1420-06* Asta</p>	
		<p>* NON FORNITO SCIOLTO NON LIVRE SEPARÉMENT NOT SUPPLIED SEPARATELY</p>	
<p>COMPLESSIVO - GROUPE - ASSEMBLY 260-4906-06</p>		<p>INDICATORE MECCANICO PRESSIONE OLIO INDICATEUR MECANIQUE PRESSION D'HUILE MECHANICAL OIL PRESSURE GAUGE</p>	
<p>MOTORE O VERSIONE MOTEUR OU ADAPTATION ENGINE OR VERSION</p>	<p>(K.9979.67)</p>	<p>TAVOLA TABLE</p>	<p>4 67 1</p>
		<p>FOGLIO FEUILLE PAGE</p>	
		<p>DATA DATE</p>	<p>2 - 73</p>

		<p>270-6745-01 Interruttore</p>	
		<p>* NON FORNITO SCIOLTO NON LIVRE SEPARÉMENT NOT SUPPLIED SEPARATELY</p>	
<p>COMPLESSIVO - GROUPE - ASSEMBLY</p>		<p>INDICATORE ELETTRICO PRESSIONE OLIO INDICATEUR ELECTRIQUE PRESSION D'HUILE ELECTRICAL OIL PRESSURE GAUGE</p>	
<p>MOTORE O VERSIONE MOTEUR OU ADAPTATION ENGINE OR VERSION</p>	<p>(K.9966.21)</p>	<p>TAVOLA TABLE</p>	<p>4 67 2</p>
		<p>FOGLIO FEUILLE PAGE</p>	
		<p>DATA DATE</p>	<p>2 - 73</p>

NOTE - REMARQUES - REMARKS

-Solo motori avvia. elettrico con dinamo e motorino.
-Seulement moteurs dém. électr. avec dynastart et démarreur.
-Only for el. start. with starter generator and motor.



CATALOGO GENERALE RICAMBI

202-1770-02
Bullone (8x1.25)

6537-9195-04
Termostato

1-7565-07
Rondella

8021-3300-77
Dado (8x1.25)

NOTE - REMARQUES - REMARKS
-Solo motori avvia. elettrico con dinamotore e motorino.
-Seulement moteurs dém. électr. avec dynastart et démarreur.
-Only for el. start. with starter generator and motor.

* NON FORNITO SCIOLTO
NON LIVRE SEPARÉMENT
NOT SUPPLIED SEPARATELY

COMPLESSIVO - GROUPE - ASSEMBLY		SPIA TEMPERATURA TESTA TEMOIN TEMPERATURE CULASSE CYL. HEAD TEMPERATURE GAUGE	TAVOLA TABLE	4	67	3
MOTORE O VERSIONE MOTEUR OU ADAPTATION ENGINE OR VERSION	(K.9978.13)		FOGLIO FEUILLE PAGE			
			DATA DATE	2-73		

422-8345-03
Spia carica batteria

6452-7245-36
Quadretto

422-5040-04
Interruttore

NOTE - REMARQUES - REMARKS

* NON FORNITO SCIOLTO
NON LIVRE SEPARÉMENT
NOT SUPPLIED SEPARATELY

COMPLESSIVO - GROUPE - ASSEMBLY		8061-7246-12	QUADRETTO DI MANOVRA TABLEAU DE BORD SWITCH PANEL	TAVOLA TABLE	4	67	4
MOTORE O VERSIONE MOTEUR OU ADAPTATION ENGINE OR VERSION	LDA96-97-100-820 (K.9967.84)			FOGLIO FEUILLE PAGE			
			DATA DATE	2-73			



CATALOGO GENERALE RICAMBI

		<p>NOTE - REMARQUES - REMARKS</p> <p>-Motore avviamento elettrico con dinamofores. -Moteur démarrage électrique avec dynastart. -For electrical starting with starter generator.</p>
<p>6100-2190-49 * Cavo regolatore - cruscotto.</p>	<p>6100-2190-51 * Cavo chiavetta - spia.</p>	<p>* NON FORNITO SCIOLTO NON LIVRE SEPARÉMENT NOT SUPPLIED SEPARATELY</p>
<p>6452-7245-38 Quadretto</p>	<p>6100-2190-50 * Cavo regolatore - dinamofores.</p>	
<p>422-8345-03 Spia carica batteria</p>	<p>6100-2190-47 * Cavo regolatore - cruscotto - dinamofores.</p>	
<p>422-5040-04 Interruttore</p>	<p>6100-2190-52 * Cavo regolatore - dinamofores.</p>	
<p>* 6452-4340-15 Guaina</p>	<p>6100-2190-48 * Cavo regolatore - cruscotto.</p>	
<p>COMPLESSIVO - GROUPE - ASSEMBLY 8061-7245-73</p>		
<p>MOTORE O VERSIONE MOTEUR OU ADAPTATION ENGINE OR VERSION</p>	<p>LDA 96-97 (K. 9967.96)</p>	<p>QUADRETTO DI MANOVRA SUL MOTORE TABLEAU DE BORD SUR LE MOTEUR SWITCH PANEL ON ENGINE</p>
		<p>FOGLIO FEUILLE PAGE</p>
		<p>DATA DATE 2 - 73</p>

		<p>NOTE - REMARQUES - REMARKS</p> <p>-Motore con piedi. -Moteur avec pieds. -Engine with mounts.</p> <p>-Motore aviam. elettrico con motorino. -Moteur dém. électr. avec démarreur. -For electrical starting with motor.</p>
<p>* 6452-4340-23 Guaina</p>	<p>6100-2190-55 * Cavo cruscotto - regolatore.</p>	<p>* NON FORNITO SCIOLTO NON LIVRE SEPARÉMENT NOT SUPPLIED SEPARATELY</p>
<p>6452-7245-39 Quadretto</p>	<p>6100-2190-53 * Cavo cruscotto - interruttore.</p>	
<p>422-8345-03 Spia olio</p>	<p>6100-2190-56 * Cavo cruscotto - motorino aviam.</p>	
<p>422-5040-04 Interruttore</p>	<p>6100-2190-54 * Cavo cruscotto - motorino aviam.</p>	
<p>* 6100-2190-51 * Cavo chiavetta - spia.</p>	<p>6452-4340-24 * Guaina</p>	
<p>COMPLESSIVO - GROUPE - ASSEMBLY 270-2900-19</p>		<p>TAVOLA TABLE 4 67 6</p>
<p>MOTORE O VERSIONE MOTEUR OU ADAPTATION ENGINE OR VERSION</p>	<p>LDA 96-97-100-820 (K. 9967.39)</p>	<p>QUADRETTO DI MANOVRA SUL MOTORE TABLEAU DE BORD SUR LE MOTEUR SWITCH PANEL ON ENGINE</p>
		<p>FOGLIO FEUILLE PAGE</p>
		<p>DATA DATE 2 - 73</p>



		<p>NOTE - REMARQUES - REMARKS</p> <p>-Motore avviamento elettrico con dinamotore. -Moteur dém. électr. avec dynastart. -For el. start. with starter generator.</p> <p>-Valido anche per motore versione marina. -Valable aussi pour moteur version marine. -Suitable also for marine version engine.</p> <p>* NON FORNITO SCIOLTO NON LIVRE SEPARÉMENT NOT SUPPLIED SEPARATELY</p>												
<p>6100-2190-49 * Cavo regolatore-cruscolfo.</p> <p>6452-7245-36 Quadretto</p> <p>422-8345-03 Spia carica batteria</p> <p>422-5040-04 Interruttore</p> <p>6452-4340-19 * Guaina</p>	<p>6100-2190-51 * Cavo chiavella-spia.</p> <p>6100-2190-58 * Cavo regolatore-dinamotore.</p> <p>6100-2190-57 * Cavo regolatore-cruscolfo-dinamotore.</p> <p>6100-2190-59 * Cavo regolatore-dinamotore.</p> <p>6100-2190-48 * Cavo regolatore-cruscolfo.</p>													
<p>COMPLESSIVO - GROUPE - ASSEMBLY 8061-7245-76</p>		<p>QUADRETTO DI MANOVRA A DISTANZA TABLEAU DE BORD A DISTANCE REMOTE SWITCH PANEL</p>												
<p>MOTORE O VERSIONE MOTEUR OU ADAPTATION ENGINE OR VERSION</p>	<p>LDA96-97-LDAM 96 (K.9967.78)</p>	<table border="1" style="width: 100%; border-collapse: collapse;"> <tr> <td>TAVOLA TABLE</td> <td style="text-align: center;">4</td> <td style="text-align: center;">67</td> <td style="text-align: center;">7</td> </tr> <tr> <td>FOGLIO FEUILLE PAGE</td> <td></td> <td></td> <td></td> </tr> <tr> <td>DATA DATE</td> <td colspan="3" style="text-align: center;">2 - 73</td> </tr> </table>	TAVOLA TABLE	4	67	7	FOGLIO FEUILLE PAGE				DATA DATE	2 - 73		
TAVOLA TABLE	4	67	7											
FOGLIO FEUILLE PAGE														
DATA DATE	2 - 73													

		<p>NOTE - REMARQUES - REMARKS</p> <p>-Motore avviamento elettrico con motorino. -Moteur démarrage électrique avec démarreur. -For electrical starting with motor.</p> <p>* NON FORNITO SCIOLTO NON LIVRE SEPARÉMENT NOT SUPPLIED SEPARATELY</p>												
<p>6100-9333-40 * Tubo</p> <p>6100-2189-07 * Cavo interruttore-motorino avviam.</p> <p>6452-7245-78 Quadretto</p> <p>6452-2615-21 Coperchio</p> <p>422-8345-03 Spia olio</p> <p>422-5040-04 Interruttore</p> <p>6100-2189-08 * Cavo interruttore-spia.</p> <p>6100-2189-05 * Cavo interruttore-regolatore tensione.</p>	<p>6100-2189-06 * Cavo interruttore-motorino avviam.</p> <p>6100-5400-60 * Manicotto 3</p> <p>6100-3616-94 * Fascella</p> <p>6100-9333-39 * Tubo</p> <p>6100-2189-03 * Cavo indicatore pressione olio-spia.</p> <p>6100-9333-14 * Tubo</p> <p>6100-9333-12 * Tubo</p> <p>6100-2189-04 * Cavo interruttore avviam.-regolatore tensione.</p>													
<p>COMPLESSIVO - GROUPE - ASSEMBLY 8061-7245-75</p>		<p>QUADRETTO DI MANOVRA A DISTANZA TABLEAU DE BORD A DISTANCE REMOTE SWITCH PANEL</p>												
<p>MOTORE O VERSIONE MOTEUR OU ADAPTATION ENGINE OR VERSION</p>	<p>(K.9967.38)</p>	<table border="1" style="width: 100%; border-collapse: collapse;"> <tr> <td>TAVOLA TABLE</td> <td style="text-align: center;">4</td> <td style="text-align: center;">67</td> <td style="text-align: center;">8</td> </tr> <tr> <td>FOGLIO FEUILLE PAGE</td> <td></td> <td></td> <td></td> </tr> <tr> <td>DATA DATE</td> <td colspan="3" style="text-align: center;">2 - 73</td> </tr> </table>	TAVOLA TABLE	4	67	8	FOGLIO FEUILLE PAGE				DATA DATE	2 - 73		
TAVOLA TABLE	4	67	8											
FOGLIO FEUILLE PAGE														
DATA DATE	2 - 73													



CATALOGO GENERALE RICAMBI

		<p style="text-align: center;">NOTE - REMARQUES - REMARKS</p>												
<p>1-1770-04 Bullone (8x1,25)6</p>	<p>270-6960-39 Puleggia</p>	<p>* NON FORNITO SCIOLTO NON LIVRE SEPAREMENT NOT SUPPLIED SEPARATELY</p>												
<p>COMPLESSIVO - GROUPE - ASSEMBLY</p>		<table border="1" style="width: 100%; border-collapse: collapse;"> <tr> <td style="width: 15%; padding: 2px;">TAVOLA TABLE</td> <td style="width: 15%; text-align: center; padding: 2px;">4</td> <td style="width: 15%; text-align: center; padding: 2px;">68</td> <td style="width: 15%; text-align: center; padding: 2px;">1</td> </tr> <tr> <td style="padding: 2px;">FOGLIO FEUILLE PAGE</td> <td style="padding: 2px;"></td> <td style="padding: 2px;"></td> <td style="padding: 2px;"></td> </tr> <tr> <td style="padding: 2px;">DATA DATE</td> <td colspan="3" style="text-align: center; padding: 2px;">2 - 73</td> </tr> </table>	TAVOLA TABLE	4	68	1	FOGLIO FEUILLE PAGE				DATA DATE	2 - 73		
TAVOLA TABLE	4	68	1											
FOGLIO FEUILLE PAGE														
DATA DATE	2 - 73													
<p>MOTORE O VERSIONE MOTEUR OU ADAPTATION ENGINE OR VERSION</p>	<p>(K.9967.77)</p>	<p>PULEGGIA AVVIAMENTO MIN. INGOMBRO POULIE DEMARRAGE ENCOMBR. REDUIT STARTING PULLEY FOR MIN. WIDTH</p>												

		<p style="text-align: center;">NOTE - REMARQUES - REMARKS</p>												
<p>270-4775-39 Guarnizione</p>	<p>8021-6800-56 Prigioniero (10x1,5) 2</p>	<p>* NON FORNITO SCIOLTO NON LIVRE SEPAREMENT NOT SUPPLIED SEPARATELY</p>												
<p>6032-1595-14 Braccio</p>	<p>6212-4055-09 Fune</p>	<p>* NON FORNITO SCIOLTO NON LIVRE SEPAREMENT NOT SUPPLIED SEPARATELY</p>												
<p>COMPLESSIVO - GROUPE - ASSEMBLY</p>		<table border="1" style="width: 100%; border-collapse: collapse;"> <tr> <td style="width: 15%; padding: 2px;">TAVOLA TABLE</td> <td style="width: 15%; text-align: center; padding: 2px;">4</td> <td style="width: 15%; text-align: center; padding: 2px;">68</td> <td style="width: 15%; text-align: center; padding: 2px;">2</td> </tr> <tr> <td style="padding: 2px;">FOGLIO FEUILLE PAGE</td> <td style="padding: 2px;"></td> <td style="padding: 2px;"></td> <td style="padding: 2px;"></td> </tr> <tr> <td style="padding: 2px;">DATA DATE</td> <td colspan="3" style="text-align: center; padding: 2px;">2 - 73</td> </tr> </table>	TAVOLA TABLE	4	68	2	FOGLIO FEUILLE PAGE				DATA DATE	2 - 73		
TAVOLA TABLE	4	68	2											
FOGLIO FEUILLE PAGE														
DATA DATE	2 - 73													
<p>MOTORE O VERSIONE MOTEUR OU ADAPTATION ENGINE OR VERSION</p>	<p>LDA 96-LDAM 96 (K.9966.24)</p>	<p>AVVIAMENTO A FUNICELLA TIRO ASSIALE DEMARRAGE PAR CORDELETTE A TIR AXIAL STARTING WITH AXIAL - PULL ROPE</p>												



CATALOGO GENERALE RICAMBI

270-8430-28
Spina

270-3835-35
Flangia

1-7565-07
Rondella 6

1-1770-06
Bullone (8x1,25) 6

270-7980-37
Scodellino

422-1240-41
Anello Seeger

270-5800-71
Molla

6035-4970-06
Ingranaggio

6035-8700-76
Supporto

3001-41
Cuscinetto

6035-6480-22
Pignone

260-9730-27
Vite (8x1,25) 6

1-1770-01
Bullone (8x1,25) 4

1-7565-07
Rondella 4

6035-2183-36
Cavallotto

270-5455-06
Manovella

NOTE - REMARQUES - REMARKS

* NON FORNITO SCIOLTO
NON LIVRE SEPAREMENT
NOT SUPPLIED SEPARATELY

COMPLESSIVO - GROUPE - ASSEMBLY	270-1470-64	TAVOLA TABLE	4	68	3
MOTORE O VERSIONE MOTEUR OU ADAPTATION ENGINE OR VERSION	LDA96-97-100-LDAM96 (K.9980.77)	FOGLIO FEUILLE PAGE	1	2	
		DATA DATE	2-73		

**AVVIAMENTO A MANOVELLA
LANCEMENT PAR MANIVELLE
HAND CRANK STARTING**

270-2125-28
CAPPELLO COMPL. (a)

270-2125-25
* Cappello

270-4400-09
* Guarnizione 0,20

270-4400-08
* Guarnizione 0,30

6035-2566-71
(b) Convogliatore

246-1165-04
Anello Benzing

270-1110-38
Albero

268-1200-34
Anello OR

270-5270-42
Leva

276-8430-23
Spina

270-5680-24
Molla

NOTE - REMARQUES - REMARKS

(a) -Vedi anche Tav. }
-Voir aussi Table } 4-37-1
-See also Table }

(b) -Vedi anche Tav. }
-Voir aussi Table } 4-23-1
-See also Table }

* NON FORNITO SCIOLTO
NON LIVRE SEPAREMENT
NOT SUPPLIED SEPARATELY

COMPLESSIVO - GROUPE - ASSEMBLY	270-1470-64	TAVOLA TABLE	4	68	3
MOTORE O VERSIONE MOTEUR OU ADAPTATION ENGINE OR VERSION	LDA96-97-100-LDAM96 (K.9980.77)	FOGLIO FEUILLE PAGE	2	2	
		DATA DATE	2-73		

**AVVIAMENTO A MANOVELLA
LANCEMENT PAR MANIVELLE
HAND CRANK STARTING**



NOTE - REMARQUES - REMARKS

270-8430-28 Spina
 270-3835-35 Flangia
 1-7565-07 Rondella 6
 1-1770-06 Bullone (8x125) 6
 270-7980-37 Serrafelino
 422-4240-41 Anello Seeger
 270-5800-71 Molla
 6035-4970-06 Ingranaggio
 6035-8700-76 Supporto
 3001-41 Cuscinetto
 6035-6480-22 Pignone
 260-9730-27 Vite (8x125) 6
 1-1770-01 Bullone (8x125) 4
 1-7565-07 Rondella 4
 6035-2183-36 Cavalotto
 270-5455-06 Manovella

* NON FORNITO SEPARATO
 NON LIVRE SEPARÉMENT
 NOT SUPPLIED SEPARATELY

COMPLESSIVO - GROUPE - ASSEMBLY	291-1470-65	AVVIAMENTO A MANOVELLA LANCEMENT PAR MANIVELLE HAND CRANK STARTING	TAVOLA TABLE	4	68	4
MOTORE O VERSIONE MOTEUR OU ADAPTATION ENGINE OR VERSION	LDA 820 (K.9981.11)		FOGLIO FEUILLE PAGE	1	2	
			DATA DATE	2-73		

NOTE - REMARQUES - REMARKS

270-2125-28 CAPPELLO COMPL. (a)
 * 270-2125-25 Cappello
 * 270-4400-09 Guarnizione 0.20
 * 270-4400-08 Guarnizione 0.30
 6035-2566-79 Convogliatore (b)
 246-1165-04 Anello Benzing
 270-1110-38 Albero
 268-4200-34 Anello OR
 270-5270-42 Leva
 276-8430-23 Spina
 270-5680-24 Molla

(a) - Vedi anche Tav. 4-37-1
 - Voir aussi Table
 - See also Table
 (b) - Vedi anche Tav. 4-23-1
 - Voir aussi Table
 - See also Table

* NON FORNITO SEPARATO
 NON LIVRE SEPARÉMENT
 NOT SUPPLIED SEPARATELY

COMPLESSIVO - GROUPE - ASSEMBLY	291-1470-65	AVVIAMENTO A MANOVELLA LANCEMENT PAR MANIVELLE HAND CRANK STARTING	TAVOLA TABLE	4	68	4
MOTORE O VERSIONE MOTEUR OU ADAPTATION ENGINE OR VERSION	LDA 820 (K.9981.11)		FOGLIO FEUILLE PAGE	2	2	
			DATA DATE	2-73		



8021-6800-56
Prigioniero (40x1.5) 2

270-4775-39
Guarnizione

6011-6426-55
Piede aspiraz.

200-4670-03
Guarnizione

260-4906-06
Indicatore pressione olio.

6032-1595-14
Braccio

6212-4055-09
Fune

236-3240-37
Dado (40x1.5) 2

30-7555-08
Rondella 2

6332-4900-86
Bullone (8x1.25)

6011-6426-56
Piede allo scarico

202-7565-11
Rondella 8

406-1780-05
Bullone (40x1.5) 8

NOTE - REMARQUES - REMARKS

(a)
-Vedi anche Tav. }
-Voir aussi Table } 4-67-1
-See also Table }

(b)
-Vedi anche Tav. }
-Voir aussi Table } 4-24-2
-See also Table }

(c)
-Vedi anche Tav. }
-Voir aussi Table } 4-68-2
-See also Table }

* NON FORNITO SCIOLTO
NON LIVRE SEPAREMENT
NOT SUPPLIED SEPARATELY

COMPLESSIVO - GROUPE - ASSEMBLY		MOTORE VERSIONE MARINA MOTEUR VERSION MARINE MARINE VERSION ENGINE	TAVOLA TABLE	4	71	1
MOTORE O VERSIONE MOTEUR OU ADAPTATION ENGINE OR VERSION	LDAM 96 (K.7350)		FOGLIO FEUILLE PAGE	1	5	
			DATA DATE	2-73		

266-6727-01
Prefiltro

238-1755-02
Bullone (5x0.8)

26-7565-03
Rondella

6068-2940-58
Curva

236-3240-37
Dado (40x1.5) 2

30-7555-08
Rondella 2

270-6800-50
Prigioniero (40x1.5) 2

270-6605-05
Pompa olio compl.

270-6800-50
Prigioniero (40x1.5) 2

30-7555-08
Rondella 2

270-3240-53
Dado (40x1.5) 2

8068-9540-79
Tubo

55-1765-02
Bullone (7x1) 2

260-7565-05
Rondella 2

260-3240-11
Bullone (7x1) 2

260-4420-01
Guarnizione

321-5460-59
Marmitta scarico

NOTE - REMARQUES - REMARKS

(d)
-Vedi anche Tav. }
-Voir aussi Table } 4-44-1
-See also Table }

(e)
-Vedi anche Tav. }
-Voir aussi Table } 4-41-3
-See also Table }

(f)
-Vedi anche Tav. }
-Voir aussi Table } 4-42-6
-See also Table }

* NON FORNITO SCIOLTO
NON LIVRE SEPAREMENT
NOT SUPPLIED SEPARATELY

COMPLESSIVO - GROUPE - ASSEMBLY		MOTORE VERSIONE MARINA MOTEUR VERSION MARINE MARINE VERSION ENGINE	TAVOLA TABLE	4	71	1
MOTORE O VERSIONE MOTEUR OU ADAPTATION ENGINE OR VERSION	LDAM 96 (K.7350)		FOGLIO FEUILLE PAGE	2	5	
			DATA DATE	2-73		



CATALOGO GENERALE RICAMBI

45-7625-12 (9) Rondella
270-4775-28 (9) Guarnizione
422-6540-07 (9) Pomello
6332-5202-03 (9) Leva
270-7565-06 (9) Rondella
205-2800-09 (9) Copiglia
260-3283-04 (9) Dado (8x1.25)
27-7625-05 (9) Rondella 2
1-3240-18 Dado (8x1.25) 6
47-1770-07 Bullone (8x1.25) 6
1-7565-07 Rondella 6
6177-3775-11 Flangia
3775-04 Flangia
6332-6870-20 (9) Prigioniero (8x1.25)
270-1760-29 (9) Bullone (6x1) 2
105-3240-08 (9) Dado (6x1) 2
202-1770-02 (9) Bullone (8x1.25) 2
1-7565-07 (9) Rondella 2
6332-1361-06 (9) Arresto
6332-9245-33 (9) Tirante
6332-5201-16 (9) Leva
6332-7400-09 (9) Ribaltino
200-2800-12 (9) Copiglia 2
6398-6426-54 (9) Piede invertitore
1-7565-07 Rondella 4
406-1770-05 Bullone (8x1.25) 4

NOTE - REMARQUES - REMARKS
 (9) -Vedi anche Tav. }
 -Voir aussi Table } 4-64-4
 -See also Table }

* NON FORNITO SCIOLTO
 NON LIVRE SEPARMENT
 NOT SUPPLIED SEPARATELY

COMPLESSIVO - GROUPE - ASSEMBLY		MOTORE VERSIONE MARINA MOTEUR VERSION MARINE MARINE VERSION ENGINE		TAVOLA TABLE	4	71	1
MOTORE O VERSIONE MOTEUR OU ADAPTATION ENGINE OR VERSION	LDAM 96 (K.7350)			FOGLIO FEUILLE PAGE	3	5	
				DATA DATE	2-73		

276-9043-15 (h) Tappo
1-7565-07 Rondella 2
47-1770-07 Bullone (8x1.25) 2
6332-2566-33 Convogliatore
5-1770-11 Bullone (8x1.25) 2
1-7565-07 Rondella 2
6011-5045-31 Invertitore-riduttore
1093-1861-22 Bullone
6549-9570-50 (h) Tubo compl.
6549-9372-23 (h) Tubo compl.
6494-8102-45 (h) Serbatoio compl.
6549-9600-76 (h) Tubo compl.
6416-6585-07 (d) Pompa alimentaz.
272-1511-62 (d) Basamento compl.

NOTE - REMARQUES - REMARKS
 (d) -Vedi anche Tav. }
 -Voir aussi Table } 4-44-1
 -See also Table }
 (h) -Vedi anche Tav. }
 -Voir aussi Table } 4-43-3
 -See also Table }

* NON FORNITO SCIOLTO
 NON LIVRE SEPARMENT
 NOT SUPPLIED SEPARATELY

COMPLESSIVO - GROUPE - ASSEMBLY		MOTORE VERSIONE MARINA MOTEUR VERSION MARINE MARINE VERSION ENGINE		TAVOLA TABLE	4	71	1
MOTORE O VERSIONE MOTEUR OU ADAPTATION ENGINE OR VERSION	LDAM 96 (K.7350)			FOGLIO FEUILLE PAGE	4	5	
				DATA DATE	2-73		

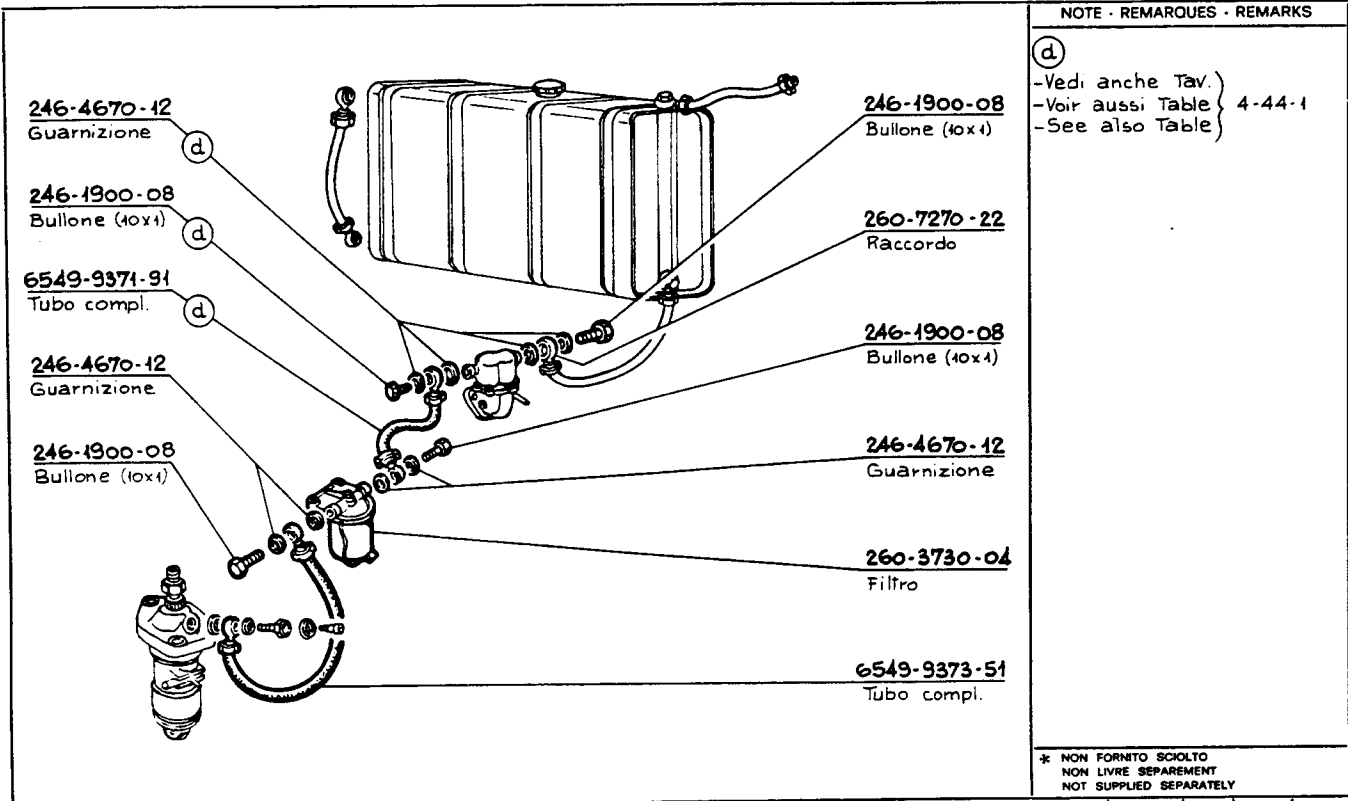

NOTE - REMARQUES - REMARKS

(d)
 -Vedi anche Tav. }
 -Voir aussi Table } 4-44-1
 -See also Table }

* NON FORNITO SCIOLTO
 NON LIVRE SEPARÉMENT
 NOT SUPPLIED SEPARATELY

COMPLESSIVO - GROUPE - ASSEMBLY		MOTORE VERSIONE MARINA MOTEUR VERSION MARINE MARINE VERSION ENGINE	TAVOLA TABLE	4	71	1
MOTORE O VERSIONE MOTEUR OU ADAPTATION ENGINE OR VERSION	LDAM 96 (K. 7350)		FOGLIO FEUILLE PAGE	5	5	
			DATA DATE	2 - 73		

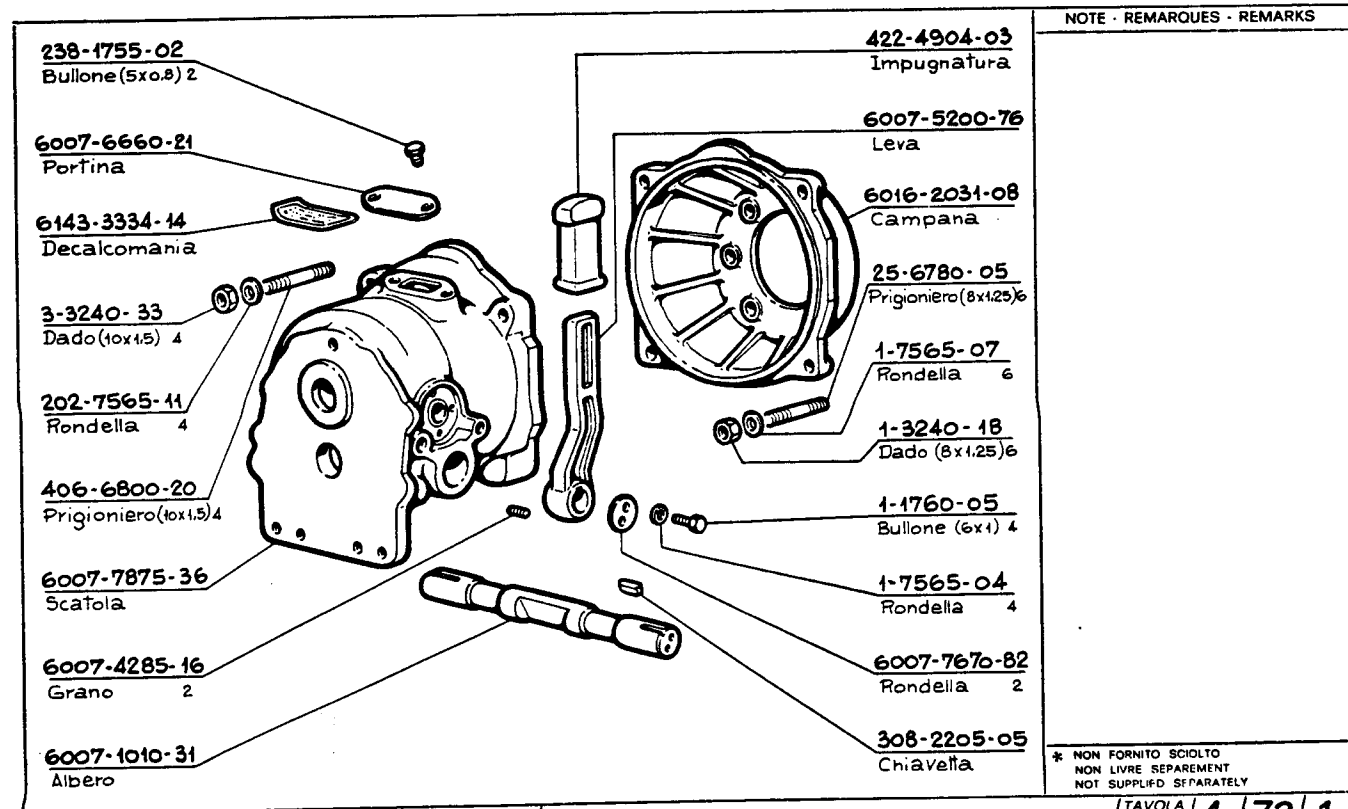

NOTE - REMARQUES - REMARKS

* NON FORNITO SCIOLTO
 NON LIVRE SEPARÉMENT
 NOT SUPPLIED SEPARATELY

COMPLESSIVO - GROUPE - ASSEMBLY		4030-49	FRIZIONE INDUSTRIALE EMBRAYAGE INDUSTRIEL INDUSTRIAL CLUTCH	TAVOLA TABLE	4	72	1
MOTORE O VERSIONE MOTEUR OU ADAPTATION ENGINE OR VERSION	LDA 96-100-820-LDAM96 (K. 9979.86-9982.57)			FOGLIO FEUILLE PAGE	1	3	
			DATA DATE	2 - 73			



999-3003-49
Cuscinello

6007-1031-08
Albero

270-9730-10
Vite (6x1) 2

25-2225-09
Chiavetta

261-3260-17
Dado (18x1,5)

23-7540-11
Rondella

6007-1037-42
Albero

6007-6040-09
Perno

6330-5680-23
Molla

1-7565-04
Rondella 4

245-1760-06
Bullone (6x1) 4

6007-5380-06
Manico

6007-3965-15
Forcella

6012-2110-29
Canotto

25-1240-21
Anello Seeger

NOTE - REMARQUES - REMARKS

* NON FORNITO SCIOLTO
NON LIVRE SEPARMENT
NOT SUPPLIED SEPARATELY

COMPLESSIVO - GROUPE - ASSEMBLY	4030-49	FRIZIONE INDUSTRIALE EMBRAYAGE INDUSTRIEL INDUSTRIAL CLUTCH	TAVOLA TABLE	4	72	1
MOTORE O VERSIONE MOTEUR OU ADAPTATION ENGINE OR VERSION	LDA96-100-820-LDAM96 (K.9979.86-9982.57)		FOGLIO FEUILLE PAGE	2	3	
			DATA DATE	2 - 73		

6007-3380-51
Disco

1-7565-04
Rondella 6

1-1760-05
Bullone (6x1) 6

6007-7653-09
Rondella

6007-3110-32
Cuscinello

6007-5499-01
Meccanismo

6007-8400-46
Spina 3

6016-2050-99
Campana

5855-02
Mozzetto

202-1770-02
Bullone (8x1,25) 6

1860-92
Bullone LDA 96-100-LDAM 96.

6016-1862-13
Bullone LDA 820.

47-3002-02
Cuscinello

NOTE - REMARQUES - REMARKS

* NON FORNITO SCIOLTO
NON LIVRE SEPARMENT
NOT SUPPLIED SEPARATELY

COMPLESSIVO - GROUPE - ASSEMBLY	4030-49	FRIZIONE INDUSTRIALE EMBRAYAGE INDUSTRIEL INDUSTRIAL CLUTCH	TAVOLA TABLE	4	72	1
MOTORE O VERSIONE MOTEUR OU ADAPTATION ENGINE OR VERSION	LDA96-100-820-LDAM96 (K.9979.86-9982.57)		FOGLIO FEUILLE PAGE	3	3	
			DATA DATE	2 - 73		



264-8990-89
Tappo

201-1780-08
Bulone (10x1.5) 6

3-3240-33
Dado (10x1.5) 6

202-7565-11
Rondella 6

8065-7875-23
Scafoia

5055-06
Lamierino 2

270-2030-90
Campana

3-6800-04
Prigioniero (10x1.5) 6

202-7565-11
Rondella 6

3-3240-33
Dado (10x1.5) 6

26-7565-03
Rondella 8

260-1755-01
Bulone (5x0.8) 8

NOTE - REMARQUES - REMARKS
 (a) -Pezzi montati sul motore; non fanno parte della frizione.
 -Pièces montées sur le moteur; ne font pas partie de l'embrayage.
 -Parts installed on engine; do not belong to clutch.

*** NON FORNITO SCIOLTO
NON LIVRE SEPARÉMENT
NOT SUPPLIED SEPARATELY**

COMPLESSIVO · GROUPE · ASSEMBLY	4030-61	FRIZIONE AUTOTRAZIONE EMBRAYAGE AUTOTRACTION AUTOMOTIVE CLUTCH	TAVOLA TABLE	4	72	2
MOTORE O VERSIONE MOTEUR OU ADAPTATION ENGINE OR VERSION	LDA96-97-100-820 (K.9965.35)		FOGLIO FEUILLE PAGE	1	3	
			DATA DATE	2 - 73		

999-1037-16
Albero

25-2225-09
Chiavetta

261-3260-17
Dado (18x1.5)

308-7565-17
Rondella

1-7565-07
Rondella 4

1-1770-04
Bulone (8x1.25) 4

8065-2110-23
Canotto

25-1240-21
Anello Seeger

999-3003-49
Cuscinetto

NOTE - REMARQUES - REMARKS

*** NON FORNITO SCIOLTO
NON LIVRE SEPARÉMENT
NOT SUPPLIED SEPARATELY**

COMPLESSIVO · GROUPE · ASSEMBLY	4030-61	FRIZIONE AUTOTRAZIONE EMBRAYAGE AUTOTRACTION AUTOMOTIVE CLUTCH	TAVOLA TABLE	4	72	2
MOTORE O VERSIONE MOTEUR OU ADAPTATION ENGINE OR VERSION	LDA96-97-100-820 (K.9965.35)		FOGLIO FEUILLE PAGE	2	3	
			DATA DATE	2 - 73		



3380-31
Disco

4030-32
Frizione

1-7565-07
Rondella 6

406-1770-05
Bullone (8x1.25) 6

3110-29
Cuscinetto

5675-02
Molla

8063-5380-08
Manicotto

202-7565-11
Rondella

5957-04
Perno

5200-35
Leva

270-2050-60
Campana

1860-92
Bullone LDA 96-97-100.

6016-1862-13
Bullone LDA 820.

47-3002-02
Cuscinetto

4030-36
FRIZIONE PITERI
COMPL.

NOTE - REMARQUES - REMARKS
 (a) - Pezzi montati sul motore; non fanno parte della frizione.
 - Pièces montées sur le moteur; ne font pas partie de l'embrayage.
 - Parts installed on engine; do not belong to clutch.

* NON FORNITO SCIOLTO
NON LIVRE SEPARÉMENT
NOT SUPPLIED SEPARATELY

COMPLESSIVO - GROUPE - ASSEMBLY	4030-61	FRIZIONE AUTOTRAZIONE EMBRAYAGE AUTOTRACTION AUTOMOTIVE CLUTCH	TAVOLA TABLE	4	72	2
MOTORE O VERSIONE MOTEUR OU ADAPTATION ENGINE OR VERSION	LDA 96-97-100-820 (K.9965.35)		FOGLIO FEUILLE PAGE	3	3	
			DATA DATE	2 - 73		

201-1780-08
Bullone (10x1.5) 6

3-3240-33
Dado (10x1.5) 6

202-7565-11
Rondella 6

8065-7875-41
Scatola

264-8990-08
Tappo

270-2030-90
Campana

3-6800-04
Prigioniero (10x1.5) 6

202-7565-11
Rondella 6

3-3240-33
Dado (10x1.5) 6

NOTE - REMARQUES - REMARKS
 - Con perno di comando.
 - Avec axe commande.
 - With control shaft.
 (a) - Pezzi montati sul motore; non fanno parte della frizione.
 - Pièces montées sur le moteur; ne font pas partie de l'embrayage.
 - Parts installed on engine; do not belong to clutch.

* NON FORNITO SCIOLTO
NON LIVRE SEPARÉMENT
NOT SUPPLIED SEPARATELY

COMPLESSIVO - GROUPE - ASSEMBLY	4031-06	FRIZIONE AUTOTRAZIONE EMBRAYAGE AUTOTRACTION AUTOMOTIVE CLUTCH	TAVOLA TABLE	4	72	3
MOTORE O VERSIONE MOTEUR OU ADAPTATION ENGINE OR VERSION	LDA 96-97-100-820 (K.9967.11)		FOGLIO FEUILLE PAGE	1	4	
			DATA DATE	2 - 73		



NOTE - REMARQUES - REMARKS

-Con perno di comando.
-Avec axe commande.
-With control shaft

COMPLESSIVO - GROUPE - ASSEMBLY	4031-06	FRIZIONE AUTOTRAZIONE EMBAYAGE AUTOTRACTION AUTOMOTIVE CLUTCH	TAVOLA TABLE	4	72	3
MOTORE O VERSIONE MOTEUR OU ADAPTATION ENGINE OR VERSION	LDA96-97-100-820 (K.9967.11)		FOGLIO FEUILLE PAGE	2	4	
			DATA DATE	2 - 73		

NOTE - REMARQUES - REMARKS

-Con perno di comando.
-Avec axe commande.
-With control shaft.

Ⓐ -Pezzi montati sul motore, non fanno parte della frizione.
-Pièces montées sur le moteur, ne font pas partie de l'embrayage.
-Parts installed on engine; do not belong to clutch.

COMPLESSIVO - GROUPE - ASSEMBLY	4031-06	FRIZIONE AUTOTRAZIONE EMBAYAGE AUTOTRACTION AUTOMOTIVE CLUTCH	TAVOLA TABLE	4	72	3
MOTORE O VERSIONE MOTEUR OU ADAPTATION ENGINE OR VERSION	LDA96-97-100-820 (K.9967.11)		FOGLIO FEUILLE PAGE	3	4	
			DATA DATE	2 - 73		



6140-51
Perno

205-1770-17
Bullone (8x1.25)

1-7565-07
Rondella

1-3240-18
Dado (8x1.25)

5200-37
Leva

202-5000-09
Ingrassatore 2

105-3240-08
Dado (6x1)

1-7565-04
Rondella

5200-44
Leva

308-7625-34
Rondella

342-1240-13
Anello Seeger

9820-63
Vite (6x1)

NOTE - REMARQUES - REMARKS
-Con perno di comando.
-Avec axe commande.
-With control shaft.

* NON FORNITO SCIOLTO
NON LIVRE SEPARMENT
NOT SUPPLIED SEPARATELY

COMPLESSIVO - GROUPE - ASSEMBLY	4031-06	FRIZIONE AUTOTRAZIONE EMBRAYAGE AUTOTRACTION AUTOMOTIVE CLUTCH	TAVOLA TABLE	4	72	3
MOTORE O VERSIONE MOTEUR OU ADAPTATION ENGINE OR VERSION	LDA96-97-100-820 (K.9967.11)		FOGLIO FEUILLE PAGE	4	4	
			DATA DATE	2 - 73		

238-1755-02
Bullone (5x0.8) 2

6007-6660-21
Portina

6143-3334-14
Decalcomania

3-3240-33
Dado (10x1.5) 4

202-7565-11
Rondella 4

406-6800-20
Prigioniero (10x1.5) 4

260-8400-21
Spina 2

6012-7875-37
Scatola

6007-4285-16
Grano 2

6007-1010-31
Albero

422-4904-03
Impugnatura

6007-5200-76
Leva

8021-2031-08
Campana

25-6780-05
Prigioniero (8x1.25) 6

1-7565-07
Rondella 6

1-3240-18
Dado (8x1.25) 6

1-1760-05
Bullone (6x1) 4

1-7565-04
Rondella 4

6007-7670-82
Rondella 2

308-2205-05
Chiave/ita

NOTE - REMARQUES - REMARKS

* NON FORNITO SCIOLTO
NON LIVRE SEPARMENT
NOT SUPPLIED SEPARATELY

COMPLESSIVO - GROUPE - ASSEMBLY	4031-08	FRIZIONE INDUSTRIALE E RIDUTTORE "A.. R.1:2 EMBRAYAGE INDUSTRIEL ET REDUCTEUR "A.. R.1:2 INDUSTRIAL CLUTCH AND RED. GEAR "A.. R.1:2	TAVOLA TABLE	4	72	4
MOTORE O VERSIONE MOTEUR OU ADAPTATION ENGINE OR VERSION	LDA96-100-820-LDAM96 (K.9979.87-9982.56)		FOGLIO FEUILLE PAGE	1	5	
			DATA DATE	2 - 73		



CATALOGO GENERALE RICAMBI

200-3002-46
Cuscinello

6007-4031-08
Albero

270-9730-10
Vite (6x1) 2

440-9800-15
Vite (8x1,25) 3

6012-1037-43
Albero

440-2710-34
Coperchio

25-1240-21
Anello Seeger

6007-6040-09
Perno

6330-5680-23
Molla

1-7565-04
Rondella 4

245-1760-06
Bullone (6x1) 4

6007-5380-06
Manicotto

6007-3965-15
Forcella

6012-2110-29
Canofo

999-1210-73
Anello Tenuta

NOTE - REMARQUES - REMARKS

* NON FORNITO SCIOLTO
NON LIVRE SEPAREMENT
NOT SUPPLIED SEPARATELY

COMPLESSIVO - GROUPE - ASSEMBLY	4031-08	FRIZIONE INDUSTRIALE E RIDUTTORE "A.. R.1:2 EMBRAYAGE INDUSTRIEL ET REDUCTEUR "A.. R.1:2 INDUSTRIAL CLUTCH AND RED. GEAR "A.. R.1:2	TAVOLA TABLE	4	72	4
MOTORE O VERSIONE MOTEUR OU ADAPTATION ENGINE OR VERSION	LDA96-100-820-LDAM96 (K.9979.87-9982.56)		FOGLIO FEUILLE PAGE	2		5
			DATA DATE	2-73		

6007-3380-51
Disco

1-7565-04
Rondella 6

1-1760-05
Bullone (6x1) 6

6007-7653-09
Rondella

6007-3110-32
Cuscinello

6007-5499-01
Meccanismo

6007-8400-46
Spina 3

5855-02
Mozzetto

202-1770-02
Bullone (8x1,25) 6

6016-2050-99
Campana

a) 1860-92
Bullone LDA 96-100-LDAM 96.

b) 6016-1862-13
Bullone LDA 820

47-3002-02
Cuscinello

NOTE - REMARQUES - REMARKS

* NON FORNITO SCIOLTO
NON LIVRE SEPAREMENT
NOT SUPPLIED SEPARATELY

COMPLESSIVO - GROUPE - ASSEMBLY	4031-08	FRIZIONE INDUSTRIALE E RIDUTTORE "A.. R.1:2 EMBRAYAGE INDUSTRIEL ET REDUCTEUR "A.. R.1:2 INDUSTRIAL CLUTCH AND RED. GEAR "A.. R.1:2	TAVOLA TABLE	4	72	4
MOTORE O VERSIONE MOTEUR OU ADAPTATION ENGINE OR VERSION	LDA96-100-820-LDAM96 (K.9979.87-9982.56)		FOGLIO FEUILLE PAGE	3		5
			DATA DATE	2-73		



CATALOGO GENERALE RICAMBI

<p>440-6192-05 Perno</p> <p>260-3004-08 Cuscinetto</p> <p>439-1210-30 Anello tenuta</p> <p>23-7540-11 Rondella</p> <p>261-3260-17 Dado (48x1.5)</p> <p>428-1750-01 Bullone (4x0.7) 2</p> <p>25-7540-02 Rondella 2</p>		<p>435-4102-04 Gabbia</p> <p>264-8990-08 Tappo</p> <p>428-7810-03 Ruota oziosa</p> <p>25-2225-09 Chiaveffa</p> <p>403-3004-06 Cuscinetto</p> <p>428-1090-15 Albero</p> <p>428-6250-09 Pescaolo</p>		<p>NOTE - REMARQUES - REMARKS</p> <p>-Rotazione uguale al motore. (antioraria). -Même rotation du moteur. (antihoraire). -Same rotation as engine. (counterclockwise).</p> <p>* NON FORNITO SCOLTO NON LIVRE SEPARÉMENT NOT SUPPLIED SEPARATELY</p>																
<p>COMPLESSIVO - GROUPE - ASSEMBLY</p>		<p>4031-08</p>		<table border="1"> <tr> <td>TAVOLA</td> <td>4</td> <td>72</td> <td>4</td> </tr> <tr> <td>FOGLIO</td> <td colspan="2"></td> <td></td> </tr> <tr> <td>FEUILLE</td> <td>4</td> <td colspan="2">5</td> </tr> <tr> <td>DATA</td> <td colspan="3">2 - 73</td> </tr> </table>	TAVOLA	4	72	4	FOGLIO				FEUILLE	4	5		DATA	2 - 73		
TAVOLA	4	72	4																	
FOGLIO																				
FEUILLE	4	5																		
DATA	2 - 73																			
<p>MOTORE O VERSIONE MOTEUR OU ADAPTATION ENGINE OR VERSION</p>		<p>LDA96-100-820-LDAM96 (K.9979.87-9982.56)</p>																		
<p>FRIZIONE INDUSTRIALE E RIDUTTORE "A.. R.1:2 EMBRAYAGE INDUSTRIEL ET REDUCTEUR "A.. R.1:2 INDUSTRIAL CLUTCH AND RED. GEAR "A.. R.1:2</p>																				

<p>*440-4430-94 Guarnizione</p> <p>25-6780-05 Prigioniero (8x1.25) 5</p> <p>1-7565-07 Rondella 5</p> <p>1-3240-18 Dado (8x1.25) 5</p> <p>26-8965-01 Tappo (40x1.5) 2</p> <p>428-4670-08 Guarnizione 2</p> <p>440-2690-25 Coperchio</p> <p>202-7565-11 Rondella 4</p> <p>3-3240-33 Dado (40x1.5) 4</p> <p>3-6800-04 Prigioniero (40x1.5) 4</p>		<p>440-7915-09 Scatola</p> <p>428-9050-16 Tappo</p> <p>224-4480-17 Guarnizione</p> <p>428-7770-51 Rullino</p> <p>440-4680-23* Guarnizione</p> <p>1-7565-07 Rondella 6</p> <p>260-9730-26 Vite (8x1.25) 6</p> <p>1-7565-07 Rondella 4</p> <p>440-9730-39 Vite (8x1.25) 4</p> <p>6012-6426-76 Piede</p>		<p>NOTE - REMARQUES - REMARKS</p> <p>-Rotazione uguale al motore. (antioraria). -Même rotation du moteur. (antihoraire). -Same rotation as engine. (counterclockwise).</p> <p>* NON FORNITO SCOLTO NON LIVRE SEPARÉMENT NOT SUPPLIED SEPARATELY</p>																
<p>COMPLESSIVO - GROUPE - ASSEMBLY</p>		<p>4031-08</p>		<table border="1"> <tr> <td>TAVOLA</td> <td>4</td> <td>72</td> <td>4</td> </tr> <tr> <td>FOGLIO</td> <td colspan="2"></td> <td></td> </tr> <tr> <td>FEUILLE</td> <td>5</td> <td colspan="2">5</td> </tr> <tr> <td>DATA</td> <td colspan="3">2 - 73</td> </tr> </table>	TAVOLA	4	72	4	FOGLIO				FEUILLE	5	5		DATA	2 - 73		
TAVOLA	4	72	4																	
FOGLIO																				
FEUILLE	5	5																		
DATA	2 - 73																			
<p>MOTORE O VERSIONE MOTEUR OU ADAPTATION ENGINE OR VERSION</p>		<p>LDA96-100-820-LDAM96 (K.9979.87-9982.56)</p>																		
<p>FRIZIONE INDUSTRIALE E RIDUTTORE "A.. R.1:2 EMBRAYAGE INDUSTRIEL ET REDUCTEUR "A.. R.1:2 INDUSTRIAL CLUTCH AND RED. GEAR "A.. R.1:2</p>																				

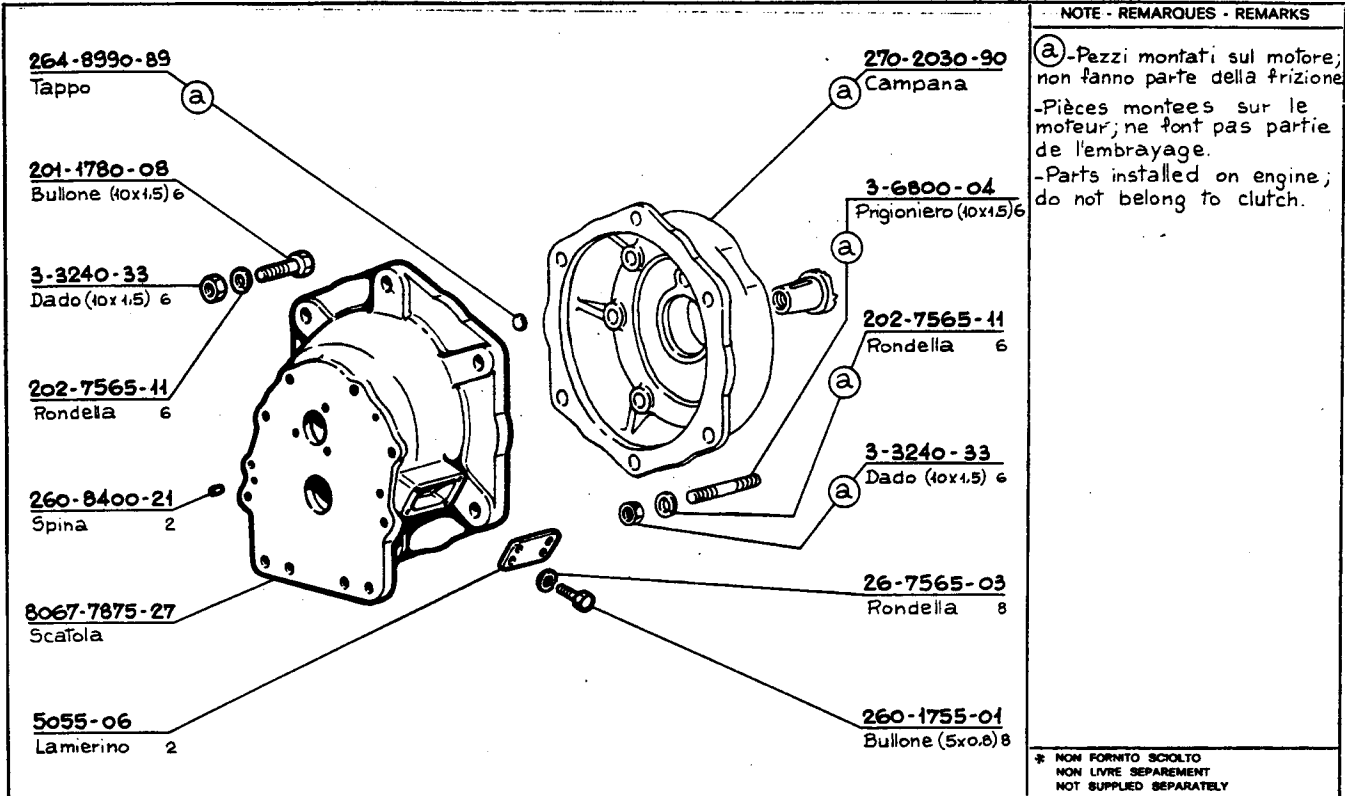

NOTE - REMARQUES - REMARKS

(a) - Pezzi montati sul motore; non fanno parte della frizione
 - Pièces montées sur le moteur; ne font pas partie de l'embrayage.
 - Parts installed on engine; do not belong to clutch.

* NON FORNITO SCIOLTO
 NON LIVRE SEPARÈMENT
 NOT SUPPLIED SEPARATELY

COMPLESSIVO - GROUPE - ASSEMBLY		4030-46	TAVOLA TABLE	4	72	5
MOTORE O VERSIONE MOTEUR OU ADAPTATION ENGINE OR VERSION	LDA96-97-100-820 (K.9965.37)	FRIZIONE AUTOTRAZIONE E RIDUTTORE "A.. R.1:2 EMBRAYAGE AUTOTRACT. ET REDUCTEUR "A..R.1:2 AUTOMOTIVE CLUTCH AND RED. GEAR "A..R.1:2	FOGLIO FEUILLE PAGE	1	5	
			DATA DATE	2 - 73		

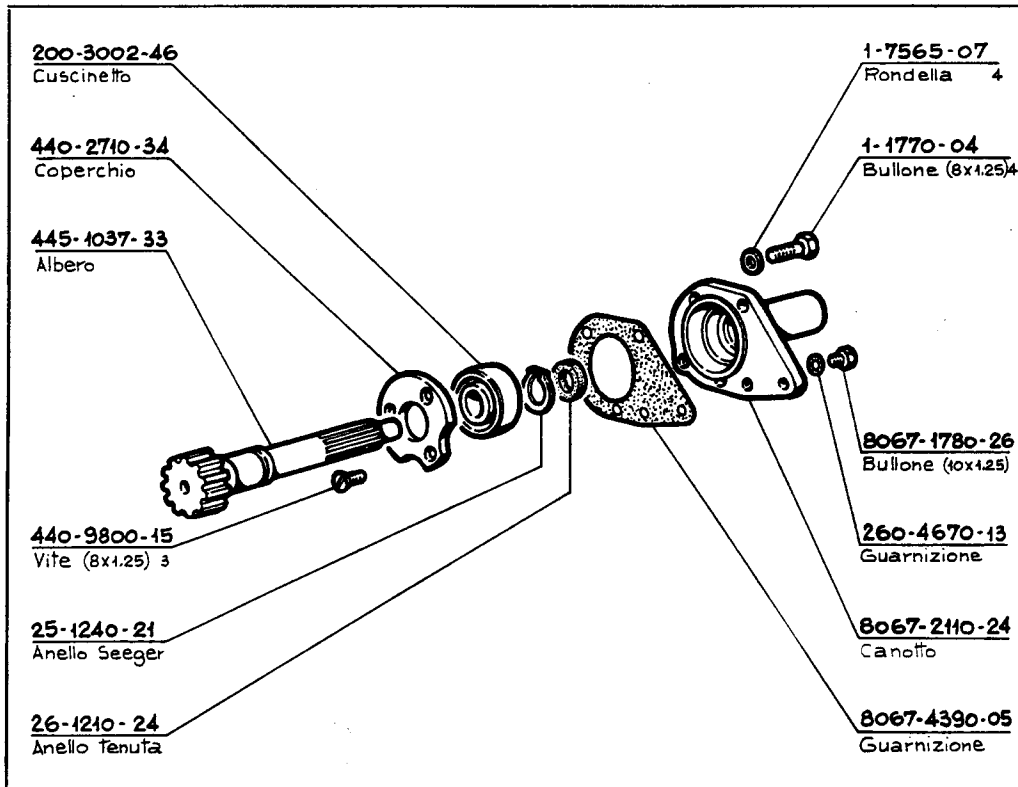

NOTE - REMARQUES - REMARKS

* NON FORNITO SCIOLTO
 NON LIVRE SEPARÈMENT
 NOT SUPPLIED SEPARATELY

COMPLESSIVO - GROUPE - ASSEMBLY		4030-46	TAVOLA TABLE	4	72	5
MOTORE O VERSIONE MOTEUR OU ADAPTATION ENGINE OR VERSION	LDA96-97-100-820 (K.9965.37)	FRIZIONE AUTOTRAZIONE E RIDUTTORE "A.. R.1:2 EMBRAYAGE AUTOTRAC. ET REDUCTEUR "A..R.1:2 AUTOMOTIVE CLUTCH AND RED. GEAR "A..R.1:2	FOGLIO FEUILLE PAGE	2	5	
			DATA DATE	2 - 73		



CATALOGO GENERALE RICAMBI

NOTE - REMARQUES - REMARKS

① - Pezzi montati sul motore, non fanno parte della frizione.
- Pièces montées sur le moteur, ne font pas partie de l'embrayage.
- Parts installed on engine; do not belong to clutch.

* NON FORNITO SCIOLTO
NON LIVRE SEPARÉMENT
NOT SUPPLIED SEPARATELY

COMPLESSIVO - GROUPE - ASSEMBLY	4030-46	FRIZIONE AUTOTRAZIONE E RIDUTTORE "A.. R.1:2 EMBRAYAGE AUTOTRAC. ET REDUCTEUR "A.. R.1:2 AUTOMOTIVE CLUTCH AND RED. GEAR "A.. R. 1:2	TAVOLA TABLE	4	72	5
MOTORE O VERSIONE MOTEUR OU ADAPTATION ENGINE OR VERSION	LDA96-97-100-820 (K.9965.37)		FOGLIO FEUILLE PAGE	3	5	
			DATA DATE	2-73		

NOTE - REMARQUES - REMARKS

-Rotazione uguale al motore.
(antioraria).
-Même rotation du moteur.
(antihoraire).
-Same rotation as engine.
(counterclockwise).

* NON FORNITO SCIOLTO
NON LIVRE SEPARÉMENT
NOT SUPPLIED SEPARATELY

COMPLESSIVO - GROUPE - ASSEMBLY	4030-46	FRIZIONE AUTOTRAZIONE E RIDUTTORE "A.. R.1:2 EMBRAYAGE AUTOTRAC. ET REDUCTEUR "A.. R.1:2 AUTOMOTIVE CLUTCH AND RED. GEAR "A.. R.1:2	TAVOLA TABLE	4	72	5
MOTORE O VERSIONE MOTEUR OU ADAPTATION ENGINE OR VERSION	LDA96-97-100-820 (K.9965.37)		FOGLIO FEUILLE PAGE	4	5	
			DATA DATE	2-73		



CATALOGO GENERALE RICAMBI

NOTE - REMARQUES - REMARKS

- Rotazione uguale al motore. (antioraria).
- Même rotation du moteur. (antihoraire).
- Same rotation as engine (counterclockwise).

* NON FORNITO SCIOLTO
NON LIVRE SEPARÉMENT
NOT SUPPLIED SEPARATELY

COMPLESSIVO - GROUPE - ASSEMBLY	4030-46	FRIZIONE AUTOTRAZIONE E RIDUTTORE "A..R.1:2 EMBRAYAGE AUTOTRAC. ET REDUCTEUR "A..R.1:2 AUTOMOTIVE CLUTCH AND RED. GEAR "A.. R.1:2	TAVOLA TABLE	4	72	5
MOTORE O VERSIONE MOTEUR OU ADAPTATION ENGINE OR VERSION	LDA96-97-100-820 (K.9965.37)		FOGLIO FEUILLE PAGE	5		5
			DATA DATE	2 - 73		

NOTE - REMARQUES - REMARKS

- Motore industriale.
- Moteur industriel.
- Industrial engine.

* NON FORNITO SCIOLTO
NON LIVRE SEPARÉMENT
NOT SUPPLIED SEPARATELY

COMPLESSIVO - GROUPE - ASSEMBLY	6241-4220-82	GIUNTO ELASTICO ACCOUPLÉMENT ELASTIQUE FLEXIBLE COUPLING	TAVOLA TABLE	4	73	1
MOTORE O VERSIONE MOTEUR OU ADAPTATION ENGINE OR VERSION	LDA 96-LDAM96 (K.9967.31)		FOGLIO FEUILLE PAGE			
			DATA DATE	2 - 73		



CATALOGO GENERALE RICAMBI

<p>45-3283-09 Dado (10x1,5) 3</p> <p>206-7625-19 Rondella 6</p> <p>6850-61 Prigioniero (10x1,5) 3</p> <p>4250-41 Giunto</p> <p>45-3283-09 Dado (10x1,5) 3</p> <p>205-2800-09 Copiglia</p>		<p>205-2800-09 Copiglia 3</p> <p>6241-8060-59 Semigiunto</p> <p>4220-17 Giunto</p> <p>6850-61 Prigioniero (10x1,5) 3</p> <p>206-7625-19 Rondella 6</p>		<p>NOTE - REMARQUES - REMARKS</p> <p>-Motore con frizione. -Moteur avec embrayage. -Engine with clutch.</p>												
<p>COMPLESSIVO - GROUPE - ASSEMBLY 6241-4220-69</p> <p>MOTORE O VERSIONE MOTEUR OU ADAPTATION ENGINE OR VERSION LDA 96-LDAM 96 (K.9978.03)</p>		<p>GIUNTO ELASTICO ACCOUPLMENT ELASTIQUE FLEXIBLE COUPLING</p>		<p>* NON FORNITO SCOLTO NON LIVRE SEPARMENT NOT SUPPLIED SEPARATELY</p> <table border="1"> <tr> <td>TAVOLA TABLE</td> <td>4</td> <td>73</td> <td>2</td> </tr> <tr> <td>FOGLIO FEUILLE PAGE</td> <td></td> <td></td> <td></td> </tr> <tr> <td>DATA DATE</td> <td colspan="3">2 - 73</td> </tr> </table>	TAVOLA TABLE	4	73	2	FOGLIO FEUILLE PAGE				DATA DATE	2 - 73		
TAVOLA TABLE	4	73	2													
FOGLIO FEUILLE PAGE																
DATA DATE	2 - 73															

<p>104-3283-10 Dado (10x1,5) 3</p> <p>206-7625-19 Rondella 3</p> <p>6241-6850-60 Prigioniero (10x1,5) 3</p> <p>6241-4250-40 Giunto</p> <p>104-3283-10 Dado (10x1,5) 3</p> <p>205-2800-09 Copiglia 3</p>		<p>205-2800-09 Copiglia 3</p> <p>6241-8060-17 Semigiunto</p> <p>4220-19 Giunto</p> <p>6241-6850-60 Prigioniero (10x1,5) 3</p> <p>206-7625-19 Rondella 3</p>		<p>NOTE - REMARQUES - REMARKS</p> <p>-Motore industriale con riduttore "A., R. 1:2. -Moteur industriel avec réducteur "A., R. 1:2. -Industrial engine with reduction gear "A., R. 1:2.</p>												
<p>COMPLESSIVO - GROUPE - ASSEMBLY 6241-4220-78</p> <p>MOTORE O VERSIONE MOTEUR OU ADAPTATION ENGINE OR VERSION LDA 96 (K.9967.32)</p>		<p>GIUNTO ELASTICO ACCOUPLMENT ELASTIQUE FLEXIBLE COUPLING</p>		<p>* NON FORNITO SCOLTO NON LIVRE SEPARMENT NOT SUPPLIED SEPARATELY</p> <table border="1"> <tr> <td>TAVOLA TABLE</td> <td>4</td> <td>73</td> <td>3</td> </tr> <tr> <td>FOGLIO FEUILLE PAGE</td> <td></td> <td></td> <td></td> </tr> <tr> <td>DATA DATE</td> <td colspan="3">2 - 73</td> </tr> </table>	TAVOLA TABLE	4	73	3	FOGLIO FEUILLE PAGE				DATA DATE	2 - 73		
TAVOLA TABLE	4	73	3													
FOGLIO FEUILLE PAGE																
DATA DATE	2 - 73															



CATALOGO GENERALE RICAMBI

<p>104-3283-10 Dado (40x1.5) 3</p> <p>206-7625-19 Rondella 3</p> <p>6241-6850-60 Prigioniero (40x1.5) 3</p> <p>6241-4250-40 Giunto</p> <p>104-3283-10 Dado (40x1.5) 3</p> <p>205-2800-09 Copiglia 3</p>		<p>205-2800-09 Copiglia 3</p> <p>6241-8060-60 Semigiunto</p> <p>4220-19 Giunto</p> <p>6241-6850-60 Prigioniero (40x1.5) 3</p> <p>206-7625-19 Rondella 3</p>		<p>NOTE - REMARQUES - REMARKS</p> <p>-Motore con frizione-riduttore -Moteur avec embrayage - red. -Engine with clutch - red. gear</p>
<p>COMPLESSIVO - GROUPE - ASSEMBLY 6141-4220-70</p>		<p>GIUNTO ELASTICO ACCOUPLLEMENT ELASTIQUE FLEXIBLE COUPLING</p>		<p>* NON FORNITO SCIOLTO NON LIVRE SEPAREMENT NOT SUPPLIED SEPARATELY</p>
<p>MOTORE O VERSIONE MOTEUR OU ADAPTATION ENGINE OR VERSION</p>	<p>LDA96-LDAM 96 (K. 9978.04)</p>	<p>TAVOLA TABLE 4 73 4</p> <p>FOGLIO FEUILLE PAGE</p> <p>DATA DATE 2 - 73</p>		

<p>104-3283-10 Dado (40x1.5) 3</p> <p>206-7625-19 Rondella 3</p> <p>6241-6850-60 Prigioniero (40x1.5) 3</p> <p>6241-4250-40 Giunto</p> <p>104-3283-10 Dado (40x1.5) 3</p> <p>205-2800-09 Copiglia 3</p>		<p>205-2800-09 Copiglia 3</p> <p>6241-3901-57 Flangia</p> <p>4220-19 Giunto</p> <p>6241-6850-60 Prigioniero (40x1.5) 3</p> <p>206-7625-19 Rondella 3</p>		<p>NOTE - REMARQUES - REMARKS</p> <p>-Motore industriale. -Moteur industriel. -Industrial engine.</p>
<p>COMPLESSIVO - GROUPE - ASSEMBLY 6241-4220-83</p>		<p>GIUNTO ELASTICO ACCOUPLLEMENT ELASTIQUE FLEXIBLE COUPLING</p>		<p>* NON FORNITO SCIOLTO NON LIVRE SEPAREMENT NOT SUPPLIED SEPARATELY</p>
<p>MOTORE O VERSIONE MOTEUR OU ADAPTATION ENGINE OR VERSION</p>	<p>LDA100-820 (K. 9981.83)</p>	<p>TAVOLA TABLE 4 73 5</p> <p>FOGLIO FEUILLE PAGE</p> <p>DATA DATE 2 - 73</p>		



CATALOGO GENERALE RICAMBI

		<p>NOTE - REMARQUES - REMARKS</p> <p>-Motore con frizione. -Moteur avec embrayage. -Engine with clutch.</p>												
<p>104-3283-10 Dado (10x1.5) 3</p> <p>206-7625-19 Rondella 3</p> <p>6241-6850-60 Prigioniero (10x1.5) 3</p> <p>6241-4250-40 Giunto</p> <p>104-3283-10 Dado (10x1.5) 3</p> <p>205-2800-09 Copiglia 3</p>	<p>205-2800-09 Copiglia 3</p> <p>6241-4220-35 Giunto</p> <p>4220-19 Giunto</p> <p>6241-6850-60 Prigioniero (10x1.5) 3</p> <p>206-7625-19 Rondella 3</p>	<p>* NON FORNITO SCIOLTO NON LIVRE SEPARMENT NOT SUPPLIED SEPARATELY</p>												
<p>COMPLESSIVO - GROUPE - ASSEMBLY 6241-4220-90</p>		<p>GIUNTO ELASTICO ACCOUPLLEMENT ELASTIQUE FLEXIBLE COUPLING</p>												
<p>MOTORE O VERSIONE MOTEUR OU ADAPTATION ENGINE OR VERSION</p>	<p>LDA 100-820 (K.9981.82)</p>	<table border="1" style="border-collapse: collapse;"> <tr> <td>TAVOLA TABLE</td> <td style="text-align: center;">4</td> <td style="text-align: center;">73</td> <td style="text-align: center;">6</td> </tr> <tr> <td>FOGLIO FEUILLE PAGE</td> <td></td> <td></td> <td></td> </tr> <tr> <td>DATA DATE</td> <td colspan="3" style="text-align: center;">2 - 73</td> </tr> </table>	TAVOLA TABLE	4	73	6	FOGLIO FEUILLE PAGE				DATA DATE	2 - 73		
TAVOLA TABLE	4	73	6											
FOGLIO FEUILLE PAGE														
DATA DATE	2 - 73													

		<p>NOTE - REMARQUES - REMARKS</p> <p>-Motore con riduttore. -Moteur avec reducteur. -Engine with red. gear.</p>												
<p>106-3283-12 Dado (12x1.5) 3</p> <p>205-7625-26 Rondella 6</p> <p>6820-18 Prigioniero (12x1.5) 3</p> <p>6241-3901-60 Flangia</p> <p>106-3283-12 Dado (12x1.5) 3</p> <p>100-2800-16 Copiglia 3</p>	<p>100-2800-16 Copiglia 3</p> <p>6241-3901-58 Flangia</p> <p>6241-4220-73 Giunto</p> <p>6820-18 Prigioniero (12x1.5) 3</p> <p>205-7625-26 Rondella 6</p>	<p>* NON FORNITO SCIOLTO NON LIVRE SEPARMENT NOT SUPPLIED SEPARATELY</p>												
<p>COMPLESSIVO - GROUPE - ASSEMBLY 6241-4220-84</p>		<p>GIUNTO ELASTICO ACCOUPLLEMENT ELASTIQUE FLEXIBLE COUPLING</p>												
<p>MOTORE O VERSIONE MOTEUR OU ADAPTATION ENGINE OR VERSION</p>	<p>LDA 100-820 (K.9981.80)</p>	<table border="1" style="border-collapse: collapse;"> <tr> <td>TAVOLA TABLE</td> <td style="text-align: center;">4</td> <td style="text-align: center;">73</td> <td style="text-align: center;">7</td> </tr> <tr> <td>FOGLIO FEUILLE PAGE</td> <td></td> <td></td> <td></td> </tr> <tr> <td>DATA DATE</td> <td colspan="3" style="text-align: center;">2 - 73</td> </tr> </table>	TAVOLA TABLE	4	73	7	FOGLIO FEUILLE PAGE				DATA DATE	2 - 73		
TAVOLA TABLE	4	73	7											
FOGLIO FEUILLE PAGE														
DATA DATE	2 - 73													



CATALOGO GENERALE RICAMBI

NOTE - REMARQUES - REMARKS

-Motore con frizione - riduttore.
-Moteur avec embrayage - red.
-Engine with clutch - red. gear.

106-3283-12
Dado (12x1.5) 3

100-2800-16
Copiglia 3

205-7625-26
Rondella 6

6241-3901-59
Flangia

6820-18
Prigioniero (12x1.5) 3

6241-4220-73
Giunto

6241-3901-58
Flangia

6820-18
Prigioniero (12x1.5) 3

106-3283-12
Dado (12x1.5) 3

100-2800-16
Copiglia

205-7625-26
Rondella 6

* NON FORNITO SCOLTO
NON LIVRE SEPAREMENT
NOT SUPPLIED SEPARATELY

COMPLESSIVO - GROUPE - ASSEMBLY 6241-4220-91

MOTORE O VERSIONE
MOTEUR OU ADAPTATION
ENGINE OR VERSION

LDA 100-820
(K.9981.81)

GIUNTO ELASTICO
ACCOUPLMENT ELASTIQUE
FLEXIBLE COUPLING

TAVOLA TABLE	4	73	8
FOGLIO FEUILLE PAGE			
DATA DATE	2 - 73		

NOTE - REMARQUES - REMARKS

Ⓐ - Solo parte in gomma.
-Seulement pièce en caout-
chouc.
-Rubber element only.

-Motore industriale.
-Moteur industriel.
-Industrial engine.

6005-1301-44
ANELLO COMPL.

6006-5880-15
Mozzo

6005-1301-21
Anello

6005-9732-08
Vite (8x1.25) 6

6004-2070-06
Campana

* NON FORNITO SCOLTO
NON LIVRE SEPAREMENT
NOT SUPPLIED SEPARATELY

COMPLESSIVO - GROUPE - ASSEMBLY 4250-68

MOTORE O VERSIONE
MOTEUR OU ADAPTATION
ENGINE OR VERSION

LDA 96
(K.9965.32)

GIUNTO CENTRIFUGO
ACCOUPLMENT CENTRIFUGE
CENTRIFUGAL COUPLING

TAVOLA TABLE	4	73	9
FOGLIO FEUILLE PAGE			
DATA DATE	2 - 73		



6005-1301-40
ANELLO COMPL.

6005-1301-38
Anello

6006-5880-23
Mozzo

6005-9732-08
Vite (8x1.25) 12

6006-2070-15
Campana

NOTE - REMARQUES - REMARKS

Ⓐ - Solo parte in gomma.
- Seulement pièce en caoutchouc.
- Rubber element only.

- Motore industriale.
- Moteur industriel.
- Industrial engine.

* NON FORNITO SCIOLTO
NON LIVRE SEPARÈMENT
NOT SUPPLIED SEPARATELY

COMPLESSIVO - GROUPE - ASSEMBLY	4250-64	GIUNTO CENTRIFUGO ACCOUPLÈMENT CENTRIFUGE CENTRIFUGAL COUPLING	TAVOLA TABLE	4	73	10
MOTORE O VERSIONE MOTEUR OU ADAPTATION ENGINE OR VERSION	LDA 100-820 (K.9979.79)		FOGLIO FEUILLE PAGE			
			DATA DATE	2 - 73		

6005-2085-54
Campana

999-3003-33
Cuscinetto

6005-1861-30
Bullone

261-1240-62
Anello Seeger

6005-5885-04
Mozzo

6005-1301-44
ANELLO COMPL.

6005-1301-21
Anello

6005-9732-08
Vite (8x1.25) 6

NOTE - REMARQUES - REMARKS

Ⓐ - Solo parte in gomma.
- Seulement pièce en caoutchouc.
- Rubber element only.

- Motore industriale.
- Moteur industriel.
- Industrial engine.

* NON FORNITO SCIOLTO
NON LIVRE SEPARÈMENT
NOT SUPPLIED SEPARATELY

COMPLESSIVO - GROUPE - ASSEMBLY	6945-56	PULEGGIA A GIUNTO CENTRIFUGO POULIE AVEC JOINT CENTRIFUGE PULLEY WITH CENTRIFUGAL COUPLING	TAVOLA TABLE	4	73	11
MOTORE O VERSIONE MOTEUR OU ADAPTATION ENGINE OR VERSION	LDA 96 (K.9967.07)		FOGLIO FEUILLE PAGE			
			DATA DATE	2 - 73		



CATALOGO GENERALE RICAMBI

6005-1301-10
ANELLO COMPL.

6005-1301-38
Anello (a)

6005-3466-16
Distanziale

422-1240-68
Anello Seeger

422-1240-41
Anello Seeger

6005-1862-03
Bullone

6005-5885-16
Mozzo

6005-9732-08
Vite (8x1,25) 12

422-3002-28
Cuscinetto

6005-2086-02
Campana

NOTE - REMARQUES - REMARKS
 (a) - Solo parte in gomma.
 - Seulement pièce en caoutchouc.
 - Rubber element only.
 - Motore industriale.
 - Moteur industriel.
 - Industrial engine.

* NON FORNITO SCOLTO
 NON LIVRE SEPARÉMENT
 NOT SUPPLIED SEPARATELY

COMPLESSIVO · GROUPE · ASSEMBLY	6945-79	PULEGGIA A GIUNTO CENTRIFUGO POULIE AVEC JOINT CENTRIFUGE PULLEY WITH CENTRIFUGAL COUPLING	TAVOLA TABLE	4	73	12
MOTORE O VERSIONE MOTEUR OU ADAPTATION ENGINE OR VERSION	LDA 100 (K.9979.78)		FOGLIO FEUILLE PAGE			
			DATA DATE	2 - 73		

6005-1301-10
ANELLO COMPL.

6005-1301-38
Anello (a)

6005-3466-16
Distanziale

422-1240-68
Anello Seeger

422-1240-41
Anello Seeger

6005-1862-20
Bullone

6005-5885-16
Mozzo

6005-9732-08
Vite (8x1,25) 12

422-3002-28
Cuscinetto

6005-2086-02
Campana

NOTE - REMARQUES - REMARKS
 (a) - Solo parte in gomma.
 - Seulement pièce en caoutchouc.
 - Rubber element only.
 - Motore industriale.
 - Moteur industriel.
 - Industrial engine.

* NON FORNITO SCOLTO
 NON LIVRE SEPARÉMENT
 NOT SUPPLIED SEPARATELY

COMPLESSIVO · GROUPE · ASSEMBLY	6945-84	PULEGGIA A GIUNTO CENTRIFUGO POULIE AVEC JOINT CENTRIFUGE PULLEY WITH CENTRIFUGAL COUPLING	TAVOLA TABLE	4	73	13
MOTORE O VERSIONE MOTEUR OU ADAPTATION ENGINE OR VERSION	LDA 820 (K.9982.51)		FOGLIO FEUILLE PAGE			
			DATA DATE	2 - 73		



CATALOGO GENERALE RICAMBI

1-7565-07
Rondella 6

1-3240-18
Dado (8x1,25) 6

999-6460-45
Pignone

999-1860-82
Bullone

999-1090-35
Albero

307-2225-13
Chiavetta

7-1780-04
Bullone (10x1,5)

202-7565-11
Rondella

7625-45
Rondella

25-8965-05
Tappo (12x1,5)

1-4480-07
Guarnizione

999-2200-07
Chiavetta

236-6780-10
Prigioniero (8x1,25) 6

999-4680-34
Guarnizione *

26-4480-04
Guarnizione

26-8965-01
Tappo (10x1,5)

999-7915-22
Scatola

26-4480-04
Guarnizione 2

26-8965-01
Tappo (10x1,5) 2

NOTE - REMARQUES - REMARKS

- Rotazione uguale al motore. (antioraria).
- Même rotation du moteur. (antihoraire).
- Same rotation as engine. (counterclockwise).
- Motore industriale.
- Moteur industriel.
- Industrial engine.

* NON FORNITO SCIOLTO
NON LIVRE SEPARÉMENT
NOT SUPPLIED SEPARATELY

COMPLESSIVO - GROUPE - ASSEMBLY	7410-56	RIDUTTORE "A", R.1:2 REDUCTEUR "A", R.1:2 REDUCTION GEAR "A", R.1:2	TAVOLA TABLE	4	74	1
MOTORE O VERSIONE MOTEUR OU ADAPTATION ENGINE OR VERSION	LDA 96-100 (K.9965.36)		FOGLIO FEUILLE PAGE	1	2	
			DATA DATE	2 - 73		

245-1760-06
Bullone (6x1) 6

204-3001-09
Cuscinello

27-1210-32
Anello Tenuta

25-2700-32
Coperchio

1-7565-04
Rondella 3

1-1760-05
Bullone (6x1) 3

25-4430-92
* Guarnizione

1-7565-04
Rondella 6

25-4700-81
Guarnizione *

25-8610-06
Supporto

204-3001-09
Cuscinello

25-3465-90
Distanziale

27-1240-28
Anello Seeger

NOTE - REMARQUES - REMARKS

- Rotazione uguale al motore. (antioraria).
- Même rotation du moteur. (antihoraire).
- Same rotation as engine. (counterclockwise).
- Motore industriale.
- Moteur industriel.
- Industrial engine.

* NON FORNITO SCIOLTO
NON LIVRE SEPARÉMENT
NOT SUPPLIED SEPARATELY

COMPLESSIVO - GROUPE - ASSEMBLY	7410-56	RIDUTTORE "A", R.1:2 REDUCTEUR "A", R.1:2 REDUCTION GEAR "A", R.1:2	TAVOLA TABLE	4	74	1
MOTORE O VERSIONE MOTEUR OU ADAPTATION ENGINE OR VERSION	LDA 96-100 (K.9965.36)		FOGLIO FEUILLE PAGE	2	2	
			DATA DATE	2 - 73		



CATALOGO GENERALE RICAMBI

1-7565-07
Rondella 6

1-3240-18
Dado (8x1,25) 6

999-6460-45
Pignone

6016-1862-19
Bullone

999-1090-35
Albero

307-2225-13
Chiavetta

7-1780-04
Bullone (40x1,5)

202-7565-11
Rondella

7625-45
Rondella

25-8965-05
Tappo (12x1,5)

1-4480-07
Guarnizione

999-2200-07
Chiavetta

236-6780-10
Prigioniero (8x1,25) 6

999-4680-34
Guarnizione *

26-4480-04
Guarnizione

26-8965-01
Tappo (40x1,5)

999-7915-22
Scatola

26-4480-04
Guarnizione 2

26-8965-01
Tappo (40x1,5) 2

NOTE - REMARQUES - REMARKS

- Rotazione uguale al motore (antioraria).
- Même rotation du moteur. (antihoraire).
- Same rotation as engine. (counterclockwise).
- Motore industriale.
- Moteur industriel.
- Industrial engine.

* NON FORNITO SCOLTO
NON LIVRE SEPARÉMENT
NOT SUPPLIED SEPARATELY

COMPLESSIVO - GROUPE - ASSEMBLY	7410-82	RIDUTTORE "A, R.1:2 REDUCTEUR "A, R.1:2 REDUCTION GEAR "A, R.1:2	TAVOLA TABLE	4	74	2
MOTORE O VERSIONE MOTEUR OU ADAPTATION ENGINE OR VERSION	LDA 820 (K.9982.50)		FOGLIO FEUILLE PAGE	1	2	
			DATA DATE	2 - 73		

245-1760-06
Bullone (6x1) 6

204-3001-09
Cuscinello

27-1210-32
Anello Tenuta

25-2700-32
Coperchio

1-7565-04
Rondella 3

1-1760-05
Bullone (6x1) 3

*** 25-4430-92**
Guarnizione

1-7565-04
Rondella 6

25-4700-81
Guarnizione *

25-8610-06
Supporto

204-3001-09
Cuscinello

25-3465-90
Disfanziale

27-1240-26
Anello Seeger

NOTE - REMARQUES - REMARKS

- Rotazione uguale al motore. (antioraria).
- Même rotation du moteur. (antihoraire).
- Same rotation as engine. (counterclockwise).
- Motore industriale.
- Moteur industriel.
- Industrial engine.

* NON FORNITO SCOLTO
NON LIVRE SEPARÉMENT
NOT SUPPLIED SEPARATELY

COMPLESSIVO - GROUPE - ASSEMBLY	7410-82	RIDUTTORE "A, R.1:2 REDUCTEUR "A, R.1:2 REDUCTION GEAR "A, R.1:2	TAVOLA TABLE	4	74	2
MOTORE O VERSIONE MOTEUR OU ADAPTATION ENGINE OR VERSION	LDA 820 (K.9982.50)		FOGLIO FEUILLE PAGE	2	2	
			DATA DATE	2 - 73		



<p>202-7565-41 Rondella 6</p> <p>201-1780-08 Bullone (10x1,5) 6</p> <p>553-8835-66 Supporto</p> <p>270-1860-74 Bullone</p> <p>5900-31 Mozzo</p>		<p>3-3240-33 Dado (10x1,5) 6</p> <p>2181-06 Catena</p> <p>6432-5400-47 Manicotto</p> <p>6450-04 Rocchetto</p> <p>2814-01 Coprigiunto</p>		<p>NOTE - REMARQUES - REMARKS</p> <p>-Bosch HY/ZFR 1/..... AR 101. Lato presa di moto, per motore con flangiatura "B".</p> <p>-Bosch HY/ZFR 1/..... AR 101. Côté prise de force, pour moteur avec bride "B".</p> <p>-Bosch HY/ZFR 1/..... AR 101. P.T.O. Side for engine with "B" flange.</p> <p>-Vedi Tav. } -Voir Table } 4-66-2/3 -See Table }</p>
<p>COMPLESSIVO - GROUPE - ASSEMBLY</p>		<p>PREDISPOSIZ. POMPA OLEODINAMICA PREDISPOS. POMPE HYDRAULIQUE HYDRAULIC PUMP ADAPTER</p>		<p>TAVOLA TABLE 4 76 1</p> <p>FOGLIO FEUILLE</p> <p>DATA DATE 2 - 73</p>
<p>MOTORE O VERSIONE MOTEUR OU ADAPTATION ENGINE OR VERSION</p>	<p>LDA 96-97-100 (K.9975.54)</p>			

<p>202-7565-41 Rondella 6</p> <p>201-1780-08 Bullone (10x1,5) 6</p> <p>8053-8835-66 Supporto</p> <p>291-1862-12 Bullone</p> <p>5900-31 Mozzo</p>		<p>3-3240-33 Dado (10x1,5) 6</p> <p>2181-06 Catena</p> <p>6432-5400-47 Manicotto</p> <p>6450-04 Rocchetto</p> <p>2814-01 Coprigiunto</p>		<p>NOTE - REMARQUES - REMARKS</p> <p>-Bosch HY/ZFR 1/..... AR 101. Lato presa di moto, per motore con flangiatura "B".</p> <p>-Bosch HY/ZFR 1/..... AR 101. Côté prise de force, pour moteur avec bride "B".</p> <p>-Bosch HY/ZFR 1/..... AR 101. P.T.O. Side for engine with "B" flange.</p> <p>-Vedi Tav. } -Voir Table } 4-66-2/3 -See Table }</p>
<p>COMPLESSIVO - GROUPE - ASSEMBLY</p>		<p>PREDISPOSIZ. POMPA OLEODINAMICA PREDISPOS. POMPE HYDRAULIQUE HYDRAULIC PUMP ADAPTER</p>		<p>TAVOLA TABLE 4 76 2</p> <p>FOGLIO FEUILLE</p> <p>DATA DATE 2 - 73</p>
<p>MOTORE O VERSIONE MOTEUR OU ADAPTATION ENGINE OR VERSION</p>	<p>LDA 820 (K.9982.58)</p>			



202-7565-11
Rondella 6

201-1780-08
Bullone (10x1,5) 6

8835-33
Supporto

270-1860-74
Bullone

5900-31
Mozzo

3-3240-33
Dado (10x1,5) 6

2181-06
Catena

5900-15
Manicotto

6450-04
Rocchetto

2814-01
Coprigiunto

NOTE - REMARQUES - REMARKS
-2PD, lato presa di moto, per motore con flangiatura "B".
-2PD, côté prise de force, pour moteur avec bride "B".
-2PD, P.T.O. Side for engine with "B" flange.
-Vedi Tav. }
-Voir Table } 4-66-2/3
-See Table }

* NON FORNITO SCIOLTO
NON LIVRE SEPARÉMENT
NOT SUPPLIED SEPARATELY

COMPLESSIVO - GROUPE - ASSEMBLY		TAVOLA TABLE	4	76	3
MOTORE O VERSIONE MOTEUR OU ADAPTATION ENGINE OR VERSION	LDA 96-97.100 (K.9965.98)	PREDISPOSIZ. POMPA OLEODINAMICA PREDISPOS. POMPE HYDRAULIQUE HYDRAULIC PUMP ADAPTER	FOGLIO FEUILLE PAGE		
			DATA DATE	2 - 73	

202-7565-11
Rondella 6

201-1780-08
Bullone (10x1,5) 6

8835-33
Supporto

291-1862-12
Bullone

5900-31
Mozzo

3-3240-33
Dado (10x1,5) 6

2181-06
Catena

5900-15
Manicotto

6450-04
Rocchetto

2814-01
Coprigiunto

NOTE - REMARQUES - REMARKS
-2PD, lato presa di moto, per motore con flangiatura "B".
-2PD, côté prise de force, pour moteur avec bride "B".
-2PD, P.T.O. Side for engine with "B" flange.
-Vedi Tav. }
-Voir Table } 4-66-2/3
-See Table }

* NON FORNITO SCIOLTO
NON LIVRE SEPARÉMENT
NOT SUPPLIED SEPARATELY

COMPLESSIVO - GROUPE - ASSEMBLY		TAVOLA TABLE	4	76	4
MOTORE O VERSIONE MOTEUR OU ADAPTATION ENGINE OR VERSION	LDA 820 (K.9982.53)	PREDISPOSIZ. POMPA OLEODINAMICA PREDISPOS. POMPE HYDRAULIQUE HYDRAULIC PUMP ADAPTER	FOGLIO FEUILLE PAGE		
			DATA DATE	2 - 73	



		<p>NOTE - REMARQUES - REMARKS</p> <p>-3PD, lato presa di moto, per motore con flangiatura "B". -3PD, côté prise de force, pour moteur avec bride "B". -3PD, P.T.O. Side for engine with "B" flange.</p> <p>-Vedi Tav. } -Voir Table } 4-66-2/3 -See Table }</p> <p>* NON FORNITO SCIOLTO NON LIVRE SEPARÉMENT NOT SUPPLIED SEPARATELY</p>												
<p>202-7565-41 Rondella 6</p> <p>201-1780-08 Bullone (10x1,5) 6</p> <p>8835-23 Supporto</p> <p>270-1860-74 Bullone</p> <p>5900-31 Mozzo</p> <p>3-3240-33 Dado (10x1,5) 6</p> <p>2181-06 Catena</p> <p>6018-5400-51 Manicotto</p> <p>6018-6450-07 Rocchetto</p> <p>2814-01 Coprigiunto</p>	<p>COMPLESSIVO - GROUPE - ASSEMBLY</p> <p>MOTORE O VERSIONE MOTEUR OU ADAPTATION ENGINE OR VERSION</p> <p>LDA 96-97-100 (K.9966.52)</p>	<p>PREDISPOSIZ. POMPA OLEODINAMICA PREDISPOS. POMPE HYDRAULIQUE HYDRAULIC PUMP ADAPTER</p> <table border="1"> <tr> <td>TAVOLA TABLE</td> <td>4</td> <td>76</td> <td>5</td> </tr> <tr> <td>FOGLIO FEUILLE PAGE</td> <td></td> <td></td> <td></td> </tr> <tr> <td>DATA DATE</td> <td colspan="3">2 - 73</td> </tr> </table>	TAVOLA TABLE	4	76	5	FOGLIO FEUILLE PAGE				DATA DATE	2 - 73		
TAVOLA TABLE	4	76	5											
FOGLIO FEUILLE PAGE														
DATA DATE	2 - 73													

		<p>NOTE - REMARQUES - REMARKS</p> <p>-3PD, lato presa di moto, per motore con flangiatura "B". -3PD, côté prise de force, pour moteur avec bride "B". -3PD, P.T.O. side for engine with "B" flange.</p> <p>-Vedi Tav. } -Voir Table } 4-66-2/3 -See Table }</p> <p>* NON FORNITO SCIOLTO NON LIVRE SEPARÉMENT NOT SUPPLIED SEPARATELY</p>												
<p>202-7565-41 Rondella 6</p> <p>201-1780-08 Bullone (10x1,5) 6</p> <p>8835-23 Supporto</p> <p>291-1862-12 Bullone</p> <p>5900-31 Mozzo</p> <p>3-3240-33 Dado (10x1,5) 6</p> <p>2181-06 Catena</p> <p>6018-5400-51 Manicotto</p> <p>6018-6450-07 Rocchetto</p> <p>2814-01 Coprigiunto</p>	<p>COMPLESSIVO - GROUPE - ASSEMBLY</p> <p>MOTORE O VERSIONE MOTEUR OU ADAPTATION ENGINE OR VERSION</p> <p>LDA 820 (K.9982.54)</p>	<p>PREDISPOSIZ. POMPA OLEODINAMICA PREDISPOS. POMPE HYDRAULIQUE HYDRAULIC PUMP ADAPTER</p> <table border="1"> <tr> <td>TAVOLA TABLE</td> <td>4</td> <td>76</td> <td>6</td> </tr> <tr> <td>FOGLIO FEUILLE PAGE</td> <td></td> <td></td> <td></td> </tr> <tr> <td>DATA DATE</td> <td colspan="3">2 - 73</td> </tr> </table>	TAVOLA TABLE	4	76	6	FOGLIO FEUILLE PAGE				DATA DATE	2 - 73		
TAVOLA TABLE	4	76	6											
FOGLIO FEUILLE PAGE														
DATA DATE	2 - 73													



CATALOGO GENERALE RICAMBI

NOTE - REMARQUES - REMARKS

-1PS, lato volano, accoppiamento diretto.
 -1PS, côté volant, accouplement direct.
 -1PS, flywheel side, direct drive.

* NON FORNITO SCOLTO
 NON LIVRE SEPARÉMENT
 NOT SUPPLIED SEPARATELY

COMPLESSIVO - GROUPE - ASSEMBLY		TAVOLA TABLE	4	76	7
MOTORE O VERSIONE MOTEUR OU ADAPTATION ENGINE OR VERSION	LDA96-97-100-820 (K.9965.54)	PREDISPOSIZ. POMPA OLEODINAMICA PREDISPOS. POMPE HYDRAULIQUE HYDRAULIC PUMP ADAPTER	FOGLIO FEUILLE PAGE		
			DATA DATE	2	73

NOTE - REMARQUES - REMARKS

-2PS, lato volano, accoppiamento diretto.
 -2PS, côté volant, accouplement direct.
 -2PS, flywheel side, direct drive.

* NON FORNITO SCOLTO
 NON LIVRE SEPARÉMENT
 NOT SUPPLIED SEPARATELY

COMPLESSIVO - GROUPE - ASSEMBLY		TAVOLA TABLE	4	76	8
MOTORE O VERSIONE MOTEUR OU ADAPTATION ENGINE OR VERSION	LDA96-97-100-820 (K.9965.55)	PREDISPOSIZ. POMPA OLEODINAMICA PREDISPOS. POMPE HYDRAULIQUE HYDRAULIC PUMP ADAPTER	FOGLIO FEUILLE PAGE		
			DATA DATE	2	73



3900-40
Flangia

260-9730-27
Vite (8x1,25) 6

1-7565-07
Rondella 6

6960-30
Puleggia

8054-2500-51
Colonna 2

8054-6357-12
Piastra

1-7565-07
Rondella 2

67-1770-19
Bullone (8x1,25) 2

272-3002-06
Cuscinetto

27-1240-28
Anello Seeger

6433-5400-36
Manicotto

8054-8835-63
Supporto

1-3240-18
Dado (8x1,25) 3

1-7565-07
Rondella 3

45-7625-12
Rondella 3

236-6780-40
Prigioniero (8x1,25) 3

NOTE - REMARQUES - REMARKS

- BOSCH HY/ZFR 1/..... AL 101.
Lato volano, accoppiam. diretto.

- BOSCH HY/ZFR 1/..... AL 101.
Côte volant, accouplém. direct.

- BOSCH HY/ZFR 1/..... AL 101.
Flywheel side, direct drive.

* NON FORNITO SCIOLTO
NON LIVRE SEPARÉMENT
NOT SUPPLIED SEPARATELY

COMPLESSIVO - GROUPE - ASSEMBLY		TAVOLA TABLE	4	76	9
MOTORE O VERSIONE MOTEUR OU ADAPTATION ENGINE OR VERSION	LDA 96-97-100-820 (K.9968.53)	PREDISPOSIZ. POMPA OLEODINAMICA PREDISPOS. POMPE HYDRAULIQUE HYDRAULIC PUMP ADAPTER	FOGLIO FEUILLE PAGE		
			DATA DATE	2	73

422-1240-58
Anello Seeger

422-3002-25
Cuscinetto

6433-8835-51
Supporto

27-1240-28
Anello Seeger

6431-5400-34
Manicotto

5900-32
Mozzetto

422-9730-09
Vite (6x1) 4

6433-7085-06
Puleggia

2400-09
Cinghietta

NOTE - REMARQUES - REMARKS

- IPD, lato volano, accoppiamento a cinghia.

- IPD, côte volant, entraînement par courroie.

- IPD, flywheel side, belt drive.

* NON FORNITO SCIOLTO
NON LIVRE SEPARÉMENT
NOT SUPPLIED SEPARATELY

COMPLESSIVO - GROUPE - ASSEMBLY		TAVOLA TABLE	4	76	10
MOTORE O VERSIONE MOTEUR OU ADAPTATION ENGINE OR VERSION	LDA 96-97-100-820 (K.9966.01)	PREDISPOSIZ. POMPA OLEODINAMICA PREDISPOS. POMPE HYDRAULIQUE HYDRAULIC PUMP ADAPTER	FOGLIO FEUILLE PAGE	1	2
			DATA DATE	2	73



CATALOGO GENERALE RICAMBI

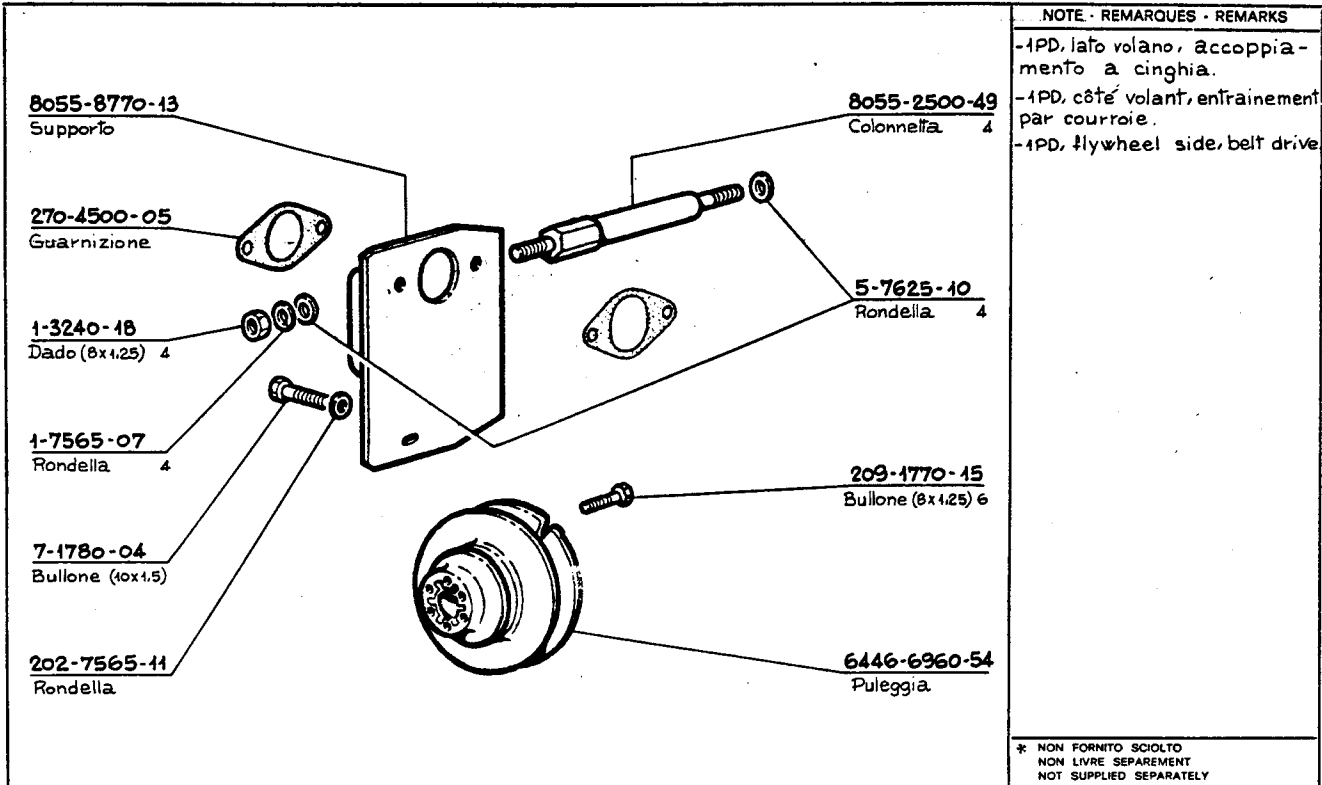

NOTE - REMARQUES - REMARKS

-1PD, lato volano, accoppiamento a cinghia.

-1PD, côté volant, entraînement par courroie.

-1PD, flywheel side, belt drive.

* NON FORNITO SCIOLTO
NON LIVRE SEPARÉMENT
NOT SUPPLIED SEPARATELY

COMPLESSIVO - GROUPE - ASSEMBLY		PREDISPOSIZ. POMPA OLEODINAMICA PRDISPOS. POMPE HYDRAULIQUE HYDRAULIC PUMP ADAPTER	TAVOLA TABLE	4	76	10
MOTORE O VERSIONE MOTEUR OU ADAPTATION ENGINE OR VERSION	LDA 96-97-100-820 (K. 9966.01)		FOGLIO FEUILLE PAGE	2	2	
			DATA DATE	2 - 73		

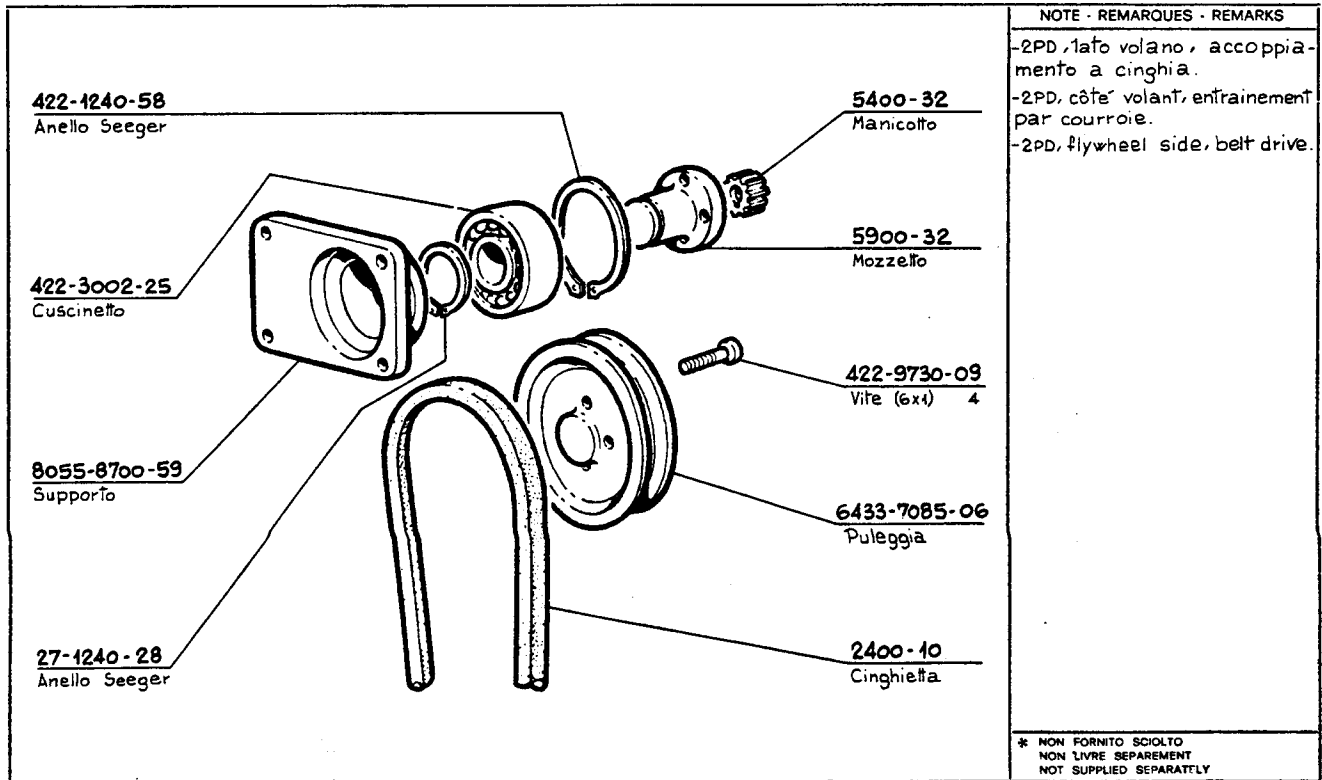

NOTE - REMARQUES - REMARKS

-2PD, lato volano, accoppiamento a cinghia.

-2PD, côté volant, entraînement par courroie.

-2PD, flywheel side, belt drive.

* NON FORNITO SCIOLTO
NON LIVRE SEPARÉMENT
NOT SUPPLIED SEPARATELY

COMPLESSIVO - GROUPE - ASSEMBLY		PREDISPOSIZ. POMPA OLEODINAMICA PREDISPOS. POMPE HYDRAULIQUE HYDRAULIC PUMP ADAPTER	TAVOLA TABLE	4	76	11
MOTORE O VERSIONE MOTEUR OU ADAPTATION ENGINE OR VERSION	LDA 96-97-100-820 (K. 9966.10)		FOGLIO FEUILLE PAGE	1	2	
			DATA DATE	2 - 73		



CATALOGO GENERALE RICAMBI

NOTE - REMARQUES - REMARKS

- 2PD, lato volano, accoppiamento a cinghia.
- 2PD, côté volant, entraînement par courroie.
- 2PD, flywheel side, belt drive.

* NON FORNITO SCIOLTO
NON LIVRE SEPARÉMENT
NOT SUPPLIED SEPARATELY

COMPLESSIVO - GROUPE - ASSEMBLY		PREDISPOSIZ. POMPA OLEODINAMICA PREDISPOS. POMPE HYDRAULIQUE HYDRAULIC PUMP ADAPTER	TAVOLA TABLE	4	76	11
MOTORE O VERSIONE MOTEUR OU ADAPTATION ENGINE OR VERSION	LDA 96-97-100-820 (K.9966.10)		FOGLIO FEUILLE PAGE	2	2	
			DATA DATE	2 - 73		

NOTE - REMARQUES - REMARKS

- 1PD, lato volano, accoppiamento con 2 cinghie.
- 1PD, côté volant, entraînement avec 2 courroies.
- 1PD, flywheel side, double belt drive.

* NON FORNITO SCIOLTO
NON LIVRE SEPARÉMENT
NOT SUPPLIED SEPARATELY

COMPLESSIVO - GROUPE - ASSEMBLY		PREDISPOSIZ. POMPA OLEODINAMICA PREDISPOS. POMPE HYDRAULIQUE HYDRAULIC PUMP ADAPTER	TAVOLA TABLE	4	76	12
MOTORE O VERSIONE MOTEUR OU ADAPTATION ENGINE OR VERSION	LDA 96-97-100-820 (K.9977.74)		FOGLIO FEUILLE PAGE	1	2	
			DATA DATE	2 - 73		



CATALOGO GENERALE RICAMBI

NOTE - REMARQUES - REMARKS

- 1PD, lato volano, accoppiamento con 2 cinghie.
- 1PD, côté volant, entraînement avec 2 courroies.
- 1PD, flywheel side, double belt drive.

* NON FORNITO SCIOLTO
NON LIVRE SEPARÉMENT
NOT SUPPLIED SEPARATELY

COMPLESSIVO - GROUPE - ASSEMBLY		PREDISPOSIZ. POMPA OLEODINAMICA PREDISPOS. POMPE HYDRAULIQUE HYDRAULIC PUMP ADAPTER	TAVOLA TABLE 4	76	12
MOTORE O VERSIONE MOTEUR OU ADAPTATION ENGINE OR VERSION	LDA 96-97-100-820 (K. 9977.74)		FOGLIO FEUILLE PAGE 2	2	
			DATA DATE	2 - 73	

NOTE - REMARQUES - REMARKS

- Bosch HY/ZFR 1/..... AR 101. Lato volano, accoppiamento a cinghia.
- Bosch HY/ZFR 1/..... AR 101. Côté volant, entraînement par courroie.
- Bosch HY/ZFR 1/..... AR 101. Flywheel side, belt drive.

* NON FORNITO SCIOLTO
NON LIVRE SEPARÉMENT
NOT SUPPLIED SEPARATELY

COMPLESSIVO - GROUPE - ASSEMBLY		PREDISPOSIZ. POMPA OLEODINAMICA PREDISPOS. POMPE HYDRAULIQUE HYDRAULIC PUMP ADAPTER	TAVOLA TABLE 4	76	13
MOTORE O VERSIONE MOTEUR OU ADAPTATION ENGINE OR VERSION	LDA96-97-100-820 (K. 9967.19)		FOGLIO FEUILLE PAGE 1	2	
			DATA DATE	2 - 73	



NOTE - REMARQUES - REMARKS

-Bosch HY/ZFR 1/..... AR 101.
Lato volano, accoppiamento a cinghia.

-Bosch HY/ZFR 1/..... AR 101.
Côte volant, entraînement par courroie.

-Bosch HY/ZFR 1/..... AR 101.
Flywheel side, belt drive.

* NON FORNITO SCOLTO /
NON LIVRE SEPARÉMENT
NOT SUPPLIED SEPARATELY

COMPLESSIVO · GROUPE · ASSEMBLY		PREDISPOSIZ. POMPA OLEODINAMICA PREDISPOS. POMPE HYDRAULIQUE HYDRAULIC PUMP ADAPTER	TAVOLA TABLE	4	76	13
MOTORE O VERSIONE MOTEUR OU ADAPTATION ENGINE OR VERSION	LDA96-97-100-820 (K. 9967.19)		FOGLIO FEUILLE PAGE	2		2
			DATA DATE	2 - 73		

NOTE - REMARQUES - REMARKS

-4 fori - Moteur industrielle.
-4 trous - Moteur industriel.
-4 hole - Industrial engine.

* NON FORNITO SCOLTO /
NON LIVRE SEPARÉMENT
NOT SUPPLIED SEPARATELY

COMPLESSIVO · GROUPE · ASSEMBLY		FLANGIA BRIDE FLANGE	TAVOLA TABLE	4	77	1
MOTORE O VERSIONE MOTEUR OU ADAPTATION ENGINE OR VERSION	LDA 96 (K. 9965.81)		FOGLIO FEUILLE PAGE			
			DATA DATE	2 - 73		



CATALOGO GENERALE RICAMBI

GRUPPO MOTOPOMPA GROUPE MOTOPOMPE PUMPING SET		POMPA POMPE PUMP			NOTE - REMARQUES - REMARKS		
MOTORE MOTEUR ENGINE	MOTTO E MATRICOLA TYPE ET REFERENCE CODEWORD AND NUMBER	MATRICOLA LOMBARDINI REFERENCE LOMBARDINI LOMBARDINI PART NUMBER	TIPO TYPE MODEL	COSTRUTTORE CONSTRUCTEUR MANUFACTURER	-Per i ricambi della pompa rivolgersi direttamente ai costruttori. -Pour les pièces de la pompe s'adresser directement aux fournisseurs. -Apply directly to suppliers for pump parts orders. * NON FORNITO SCOLTO NON LIVRE SEPARÉMENT NOT SUPPLIED SEPARATELY		
LDA 96	TIGLIO 7455	6009-6581-88	B.3 x R/A 158 M	GLISENTI CASTER VIA ITALIA, 75 25060 CARCINA (BS)			
LDA 96	TAZZA 7445	6009-6581-63	MFC G1/80-72/140	CAPRARI VIA EMILIA OVEST, 900 41100 MODENA			
LDA 96	TELA 7454	6009-6581-64	MFC G1/65-73/150				
LDA 96	TRONBA 7440	6009-6581-67	MFC G40/3-76/144.5				
LDA 96	TEMPIO 7459	6009-6581-68	D 30/7/135				
LDA 96	TINO 7450	6009-6581-57	NARO	MELLINI - MARTIGNONI VIA CIRCONVALLAZIONE, 22 42016 GUASTALLA (RE)			
LDA 96	TOGA 7457	6009-6581-58	NARDO				
LDA 96	TRIONFO 7458	6009-6581-60	NORCIA				
LDA 820	VANGA 7699	6009-6582-09	PARONA 167				
LDA 820	VASCA 7675	6009-6582-05	PIRRI 105/199				
LDA 820	VEGLIA 7700	6009-6582-10	PRATO 223				
LDA 820	VELOCE 7701	6009-6582-11	POLA 168				
COMPLESSIVO - GROUPE - ASSEMBLY		TABELLA COSTRUTTORI POMPE TABLE FOURNISSEUR POMPES PUMP SUPPLIER DIRECTORY				TAVOLA TABLE 4 81 1 FOGLIO FEUILLE PAGE DATA DATE 2 - 73	
MOTORE O VERSIONE MOTEUR OU ADAPTATION ENGINE OR VERSION							

COMPLESSIVO - GROUPE - ASSEMBLY		EQUILIBRATORE DINAMICO EQUILIBREUR DYNAMIQUE DYNAMIC BALANCER			NOTE - REMARQUES - REMARKS	
MOTORE O VERSIONE MOTEUR OU ADAPTATION ENGINE OR VERSION		LDA 96-100-LDAM 96 (K.9967.18)			-Con presa di moto industr. per motore flangiato, basamento predisposto. -Avec prise de force industr. pour moteur avec bride, moteur predispose. -With industrial P.T.O. for flanged engine, special crankcase. -Vedi anche Tav. 4-21-3 -Voir aussi Table 4-21-5	
		276-1900-61 Bullone (8x1.25) 270-9410-22 Tubo 200-4670-03 Guarnizione 2 260-1900-46 Bullone 270-2690-47 Coperchio 200-4670-03 Guarnizione 2 1-1240-51 Anello Seeger 270-1585-01 Boccia 270-1860-74 Bullone 70-1970-39 Bussola 2 417-1210-38 Anello tenuta 270-9731-41 Vite (8x1.25) 10 270-4431-12 Guarnizione *			* NON FORNITO SCOLTO NON LIVRE SEPARÉMENT NOT SUPPLIED SEPARATELY	
COMPLESSIVO - GROUPE - ASSEMBLY		TAVOLA TABLE 4 82 1				
MOTORE O VERSIONE MOTEUR OU ADAPTATION ENGINE OR VERSION		FOGLIO FEUILLE PAGE 1 2				
		DATA DATE 2 - 73				



NOTE - REMARQUES - REMARKS

- Con presa di moto industr. per motore flangiato, basamento predisposto.
- Avec prise de force industr. pour moteur avec bride, moteur predisposé.
- With industrial P.T.O. for flanged engine, special crankcase.
- Vedi anche Tav. } 4-21-3
- Voir aussi Table } 4-21-5
- See also Table } 4-21-5

*** NON FORNITO SCOLTO
NON LIVRE SEPARÉMENT
NOT SUPPLIED SEPARATELY**

COMPLESSIVO - GROUPE - ASSEMBLY		EQUILIBRATORE DINAMICO EQUILIBREUR DYNAMIQUE DYNAMIC BALANCER	TAVOLA TABLE	4	82	1
MOTORE O VERSIONE MOTEUR OU ADAPTATION ENGINE OR VERSION	LDA 96-100-LDAM 96 (K.9967.18)		FOGLIO FEUILLE PAGE	2	2	
			DATA DATE	2 - 73		

NOTE - REMARQUES - REMARKS

- Flangiatura terminale "B" per motore flangiato, con basamento predisposto.
- Bride accoupl. "B" pour moteur avec bride, moteur predisposé.
- "B" output flange, for flanged engine, special crankcase.
- Vedi Tav. } 4-66-2/3
- Voir Table } 4-66-2/3
- See Table } 4-66-2/3
- Vedi anche Tav. } 4-21-3
- Voir aussi Table } 4-21-5
- See also Table } 4-21-5

*** NON FORNITO SCOLTO
NON LIVRE SEPARÉMENT
NOT SUPPLIED SEPARATELY**

COMPLESSIVO - GROUPE - ASSEMBLY		EQUILIBRATORE DINAMICO EQUILIBREUR DYNAMIQUE DYNAMIC BALANCER	TAVOLA TABLE	4	82	2
MOTORE O VERSIONE MOTEUR OU ADAPTATION ENGINE OR VERSION	LDA 96-97-100 (K.9966.94)		FOGLIO FEUILLE PAGE	1	2	
			DATA DATE	2 - 73		



CATALOGO GENERALE RICAMBI

270-1585-02
Boccola

272-4990-22
Ingranaggio

270-7700-72
Rondella

270-1240-79
Anello Seeger

456-2200-05
Chiaveffa

6017-6900-80
Prolunga

270-9731-30
Vite (8x1,25) 6

270-1861-53
Bullone

270-3900-75
Flangia

270-3466-06
Distanziale

260-9765-01
Vite (6x1)

270-9731-39
Vite (8x1,25) 5

270-6230-77
Perno

270-7950-39
Scatola

3-6800-04
Prigioniero (40x1,5) 6

202-7565-11
Rondella 6

3-3240-33
Dado (40x1,5) 6

NOTE - REMARQUES - REMARKS

-Flangiatura terminale "B", per motore flangiato, con basamento predisposto.

-Bride accoupl. "B" pour moteur avec bride, moteur predisposé.

-"B" output flange, for flanged engine, special crankcase.

-Vedi Tav. }
-Voir Table } 4-66-2/3
-See Table }

-Vedi anche Tav. }
-Voir aussi Table } 4-21-3
-See also Table } 4-21-5

* NON FORNITO SCIOLTO
NON LIVRE SEPARÉMENT
NOT SUPPLIED SEPARATELY

COMPLESSIVO - GROUPE - ASSEMBLY		EQUILIBRATORE DINAMICO EQUILIBREUR DYNAMIQUE DYNAMIC BALANCER	TAVOLA TABLE	4	82	2
MOTORE O VERSIONE MOTEUR OU ADAPTATION ENGINE OR VERSION	LDA 96-97400 (K.9966.94)		FOGLIO FEUILLE PAGE	2		2
			DATA DATE	2 - 73		

270-1050-07
Albero

NOTE - REMARQUES - REMARKS

-Versione industriale.
-Version industrielle.
-Industrial version.

* NON FORNITO SCIOLTO
NON LIVRE SEPARÉMENT
NOT SUPPLIED SEPARATELY

COMPLESSIVO - GROUPE - ASSEMBLY		1560-16	BLOCCO MOTORE BLOC MOTEUR SHORT BLOCK	TAVOLA TABLE	4	83	1
MOTORE O VERSIONE MOTEUR OU ADAPTATION ENGINE OR VERSION	LDA 100 (K.1560.16)			FOGLIO FEUILLE PAGE			
				DATA DATE	2 - 73		



NOTE - REMARQUES - REMARKS

-Versione autotrazione.
-Version autotraction.
-Automotive version.

* NON FORNITO SCIOLTO
NON LIVRE SEPAREMENT
NOT SUPPLIED SEPARATELY

COMPLESSIVO · GROUPE · ASSEMBLY	1560-15	BLOCCO MOTORE BLOC MOTEUR SHORT BLOCK	TAVOLA TABLE	4	83	2
MOTORE O VERSIONE MOTEUR OU ADAPTATION ENGINE OR VERSION	LDA 100 (K.1560.15)		FOGLIO FEUILLE PAGE			
			DATA DATE	2 - 73		

* 270-4500-52
Guarnizione (a)

* 270-4560-04
Guarnizione (a)

* 270-4500-05
Guarnizione 2 (b)

* 272-4410-08
Guarnizione 0.10 3 (c)

* 272-4410-17
Guarnizione 0.30 (c)

* 4700-74
Guarnizione 0.10 2 (d)

* 270-4700-08
Guarnizione 0.30 2 (d)

* 270-4775-11
Guarnizione (e)

* 270-4535-09
Guarnizione (f)

* 270-4535-07
Guarnizione (f)

270-4400-02
Guarnizione (g)

270-4775-39
Guarnizione 2 (h)

260-4580-04
Guarnizione 0.10 2 (i)

260-4580-12
Guarnizione 0.30 2 (i)

260-4580-08
Guarnizione 0.50 2 (i)

270-4700-69
Guarnizione (l)

270-4700-70
Guarnizione 0.50 (m)

270-4700-74
Guarnizione 1 (n)

270-4600-11
Guarnizione (n)

270-4760-06
Guarnizione (n)

NOTE - REMARQUES - REMARKS

-Fino a } LDA 96
-Jusqu'au } LDAM 96 N° 497643
-Below } LDA 97 N° 505953

(a) 4-35-3
(b) 4-41-1
(c) 4-22-1
(d) 4-21-7
(e) 4-21-6
(f) 4-35-1
(g) 4-22-6
(h) 4-42-1
(i) 4-45-1
(l) 4-64-1
(m) 4-36-1
(n) 4-21-8

-Vedi Tav.
-Voir Table
-See Table

* NON FORNITO SCIOLTO
NON LIVRE SEPAREMENT
NOT SUPPLIED SEPARATELY

COMPLESSIVO · GROUPE · ASSEMBLY	272-8180-10	SERIE GUARNIZIONI JEU DE JOINTS GASKET SET	TAVOLA TABLE	4	84	1
MOTORE O VERSIONE MOTEUR OU ADAPTATION ENGINE OR VERSION	LDA 96-97 LDAM 96		FOGLIO FEUILLE PAGE			
			DATA DATE	2 - 73		



<p>270-4730-21 Guarnizione</p> <p>270-4500-05 Guarnizione 2</p> <p>272-4410-08 Guarnizione 0.10 3</p> <p>272-4410-17 Guarnizione 0.30</p> <p>4700-74 Guarnizione 0.10 2</p> <p>270-4700-08 Guarnizione 0.30 2</p> <p>270-4431-10 Guarnizione 0.10 2</p> <p>270-4431-04 Guarnizione 0.30 2</p> <p>270-4600-91 Guarnizione</p> <p>270-4535-13 Guarnizione 2</p>		<p>270-4400-08 Guarnizione 0.20</p> <p>270-4400-09 Guarnizione 0.30</p> <p>270-4400-07 Guarnizione 0.50</p> <p>270-4775-39 Guarnizione 2</p> <p>260-4580-01 Guarnizione 0.10 2</p> <p>260-4580-12 Guarnizione 0.30 2</p> <p>260-4580-08 Guarnizione 0.50 2</p> <p>270-4700-69 Guarnizione</p> <p>270-4700-70 Guarnizione 0.50</p> <p>270-4700-71 Guarnizione 1</p> <p>271-4760-07 Guarnizione</p>		<p>NOTE - REMARQUES - REMARKS</p> <p>- Da LDA 96 - A partir de LDAM 96 N° 497644 - Starting from LDA 97 N° 505954</p> <p>(a) 4-57-1 (b) 4-41-1 (c) 4-22-1 (d) 4-21-7 (e) 4-21-6 (f) 4-21-8 (g) 4-35-2 (h) 4-22-6/4-37-1 (i) 4-42-1 (l) 4-45-1 (m) 4-64-1 (n) 4-36-1</p> <p>-Vedi Tav. -Voir Table -See Table</p> <p>* NON FORNITO SCIOLTO NON LIVRE SEPARÉMENT NOT SUPPLIED SEPARATELY</p>
<p>COMPLESSIVO - GROUPE - ASSEMBLY 272-8180-24</p>		<p>SERIE GUARNIZIONI JEU DE JOINTS GASKET SET</p>		<p>TAVOLA TABLE 4 84 2</p> <p>FOGLIO FEUILLE</p> <p>PAGE</p> <p>DATA DATE 2 - 73</p>
<p>MOTORE O VERSIONE MOTEUR OU ADAPTATION ENGINE OR VERSION</p> <p>LDA 96-97 LDAM 96</p>				

<p>270-4730-21 Guarnizione</p> <p>422-4775-42 Guarnizione</p> <p>270-4500-05 Guarnizione 2</p> <p>279-4410-23 Guarnizione 0.10 3</p> <p>279-4410-24 Guarnizione 0.30</p> <p>4700-74 Guarnizione 0.10 2</p> <p>270-4700-08 Guarnizione 0.30 2</p> <p>270-4431-10 Guarnizione 0.10 2</p> <p>270-4431-04 Guarnizione 0.30 2</p> <p>270-4600-91 Guarnizione</p> <p>270-4535-13 Guarnizione 2</p>		<p>270-4400-08 Guarnizione 0.20</p> <p>270-4400-09 Guarnizione 0.30</p> <p>270-4400-07 Guarnizione 0.50</p> <p>270-4775-39 Guarnizione 2</p> <p>260-4580-01 Guarnizione 0.10 2</p> <p>260-4580-12 Guarnizione 0.30 2</p> <p>260-4580-08 Guarnizione 0.50 2</p> <p>270-4700-69 Guarnizione</p> <p>270-4700-70 Guarnizione 0.50</p> <p>270-4700-71 Guarnizione 1</p> <p>271-4760-07 Guarnizione</p>		<p>NOTE - REMARQUES - REMARKS</p> <p>(a) 4-57-1 (b) 4-61-2 (c) 4-41-1 (d) 4-22-1 (e) 4-21-7 (f) 4-21-6 (g) 4-21-8 (h) 4-35-2 (i) 4-22-6/4-37-1 (l) 4-42-1 (m) 4-45-1 (n) 4-64-1 (o) 4-36-1</p> <p>-Vedi Tav. -Voir Table -See Table</p> <p>* NON FORNITO SCIOLTO NON LIVRE SEPARÉMENT NOT SUPPLIED SEPARATELY</p>
<p>COMPLESSIVO - GROUPE - ASSEMBLY 279-8180-27</p>		<p>SERIE GUARNIZIONI JEU DE JOINTS GASKET SET</p>		<p>TAVOLA TABLE 4 84 3</p> <p>FOGLIO FEUILLE</p> <p>PAGE</p> <p>DATA DATE 2 - 73</p>
<p>MOTORE O VERSIONE MOTEUR OU ADAPTATION ENGINE OR VERSION</p> <p>LDA 100</p>				



CATALOGO GENERALE RICAMBI

<p>* 270-4730-21 Guarnizione</p> <p>* 422-4775-42 Guarnizione</p> <p>* 270-4500-05 Guarnizione 2</p> <p>* 291-4410-37 Guarnizione 0.10 3</p> <p>* 291-4410-38 Guarnizione 0.30</p> <p>* 4700-74 Guarnizione 0.10 2</p> <p>* 270-4700-08 Guarnizione 0.30 2</p> <p>* 270-4431-10 Guarnizione 0.10 2</p> <p>* 270-4431-04 Guarnizione 0.30 2</p> <p>276-4500-79 Guarnizione</p> <p>* 270-4535-13 Guarnizione 2</p>		<p>270-4400-08 Guarnizione 0.20 *</p> <p>270-4400-09 Guarnizione 0.30 *</p> <p>270-4400-07 Guarnizione 0.50 *</p> <p>270-4775-39 Guarnizione 2</p> <p>260-4580-01 Guarnizione 0.10 2 *</p> <p>260-4580-12 Guarnizione 0.30 2 *</p> <p>260-4580-08 Guarnizione 0.50 2 *</p> <p>270-4700-69 Guarnizione *</p> <p>270-4700-70 Guarnizione 0.50 *</p> <p>270-4700-71 Guarnizione 1 *</p> <p>270-4600-91 Guarnizione</p> <p>271-4760-07 Guarnizione</p>		<p>NOTE - REMARQUES - REMARKS</p> <p>(a) 4-57-1</p> <p>(b) 4-61-2</p> <p>(c) 4-41-1</p> <p>(d) 4-22-1</p> <p>(e) 4-21-7</p> <p>(f) 4-21-6</p> <p>(g) 4-42-3/4/5</p> <p>(h) 4-35-2</p> <p>(i) 4-22-6/4-37-1</p> <p>(l) 4-42-1</p> <p>(m) 4-45-1</p> <p>(n) 4-64-1</p> <p>(o) 4-36-1</p> <p>(p) 4-21-8</p> <p>-Vedi Tav. -Voir Table -See Table</p>
<p>COMPLESSIVO - GROUPE - ASSEMBLY</p>		<p>291-8180-38</p>		
<p>MOTORE O VERSIONE MOTEUR OU ADAPTATION ENGINE OR VERSION</p>		<p>LDA 820</p>		
		<p>SERIE GUARNIZIONI JEU DE JOINTS GASKET SET</p>		
		<p>TAVOLA TABLE</p>		
		<p>4 84 4</p>		
		<p>FOGLIO FEUILLE PAGE</p>		
		<p>DATA DATE</p>		
		<p>2 - 73</p>		

<p>* 7-2300-52 Chiave</p> <p>* 9-2300-53 Chiave</p> <p>6212-4055-03 Fune</p>		<p>272-5300-41 Libretto</p> <p>7968-02 Scheda service</p> <p>270-1980-03 Busta</p>		<p>NOTE - REMARQUES - REMARKS</p>
<p>COMPLESSIVO - GROUPE - ASSEMBLY</p>		<p>272-8140-13</p>		
<p>MOTORE O VERSIONE MOTEUR OU ADAPTATION ENGINE OR VERSION</p>		<p>SERIE ACCESSORI JEU ACCESSOIRES ACCESSORY SET</p>		
		<p>TAVOLA TABLE</p>		
		<p>4 85 1</p>		
		<p>FOGLIO FEUILLE PAGE</p>		
		<p>DATA DATE</p>		
		<p>2 - 73</p>		



CATALOGO GENERALE RICAMBI

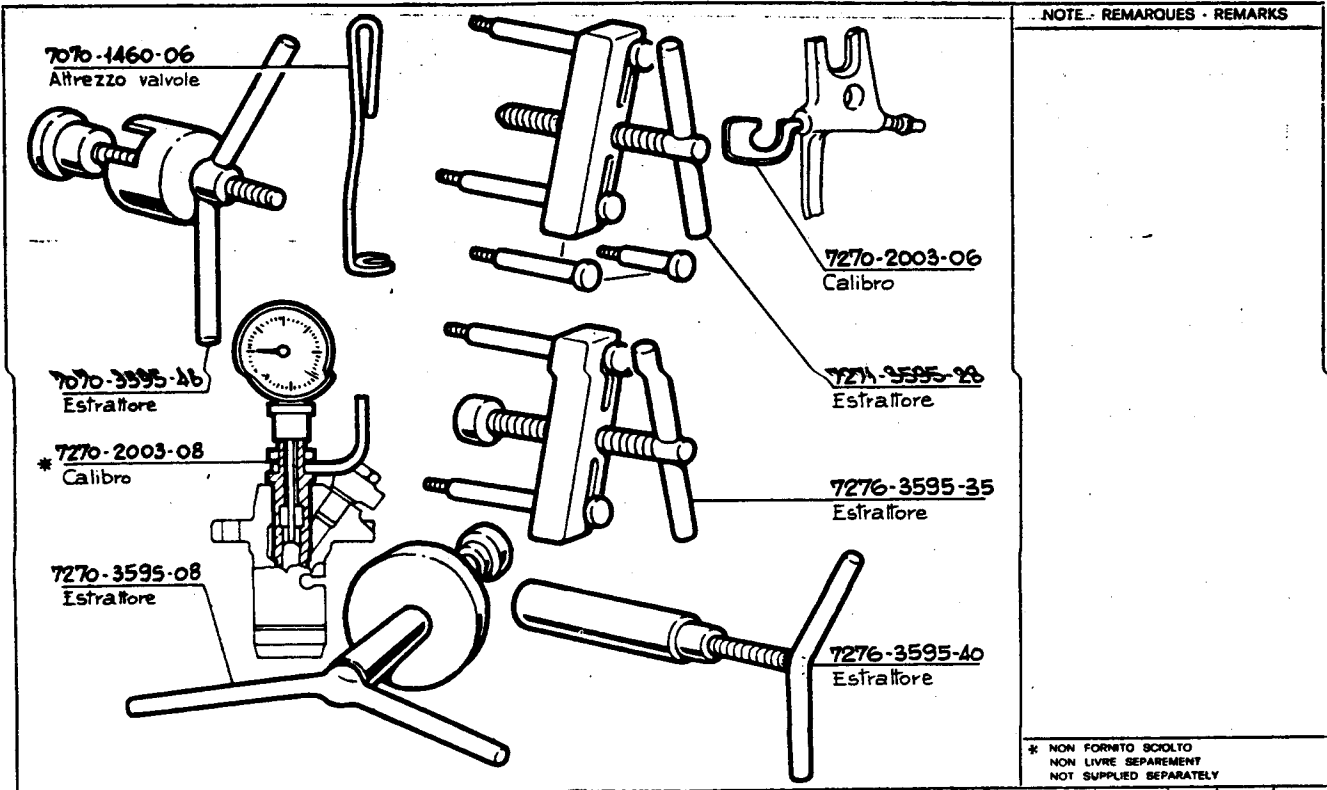

NOTE - REMARQUES - REMARKS

* NON FORNITO SCOLTO
NON LIVRE SEPAREMENT
NOT SUPPLIED SEPARATELY

COMPLESSIVO - GROUPE - ASSEMBLY		ATTREZZATURA SPECIALE OUTILLAGES SPECIFIQUES SPECIAL TOOLS	TAVOLA TABLE	4	85	2
MOTORE O VERSIONE MOTEUR OU ADAPTATION ENGINE OR VERSION			FOGLIO FEUILLE PAGE			
			DATA DATE	2 - 73		

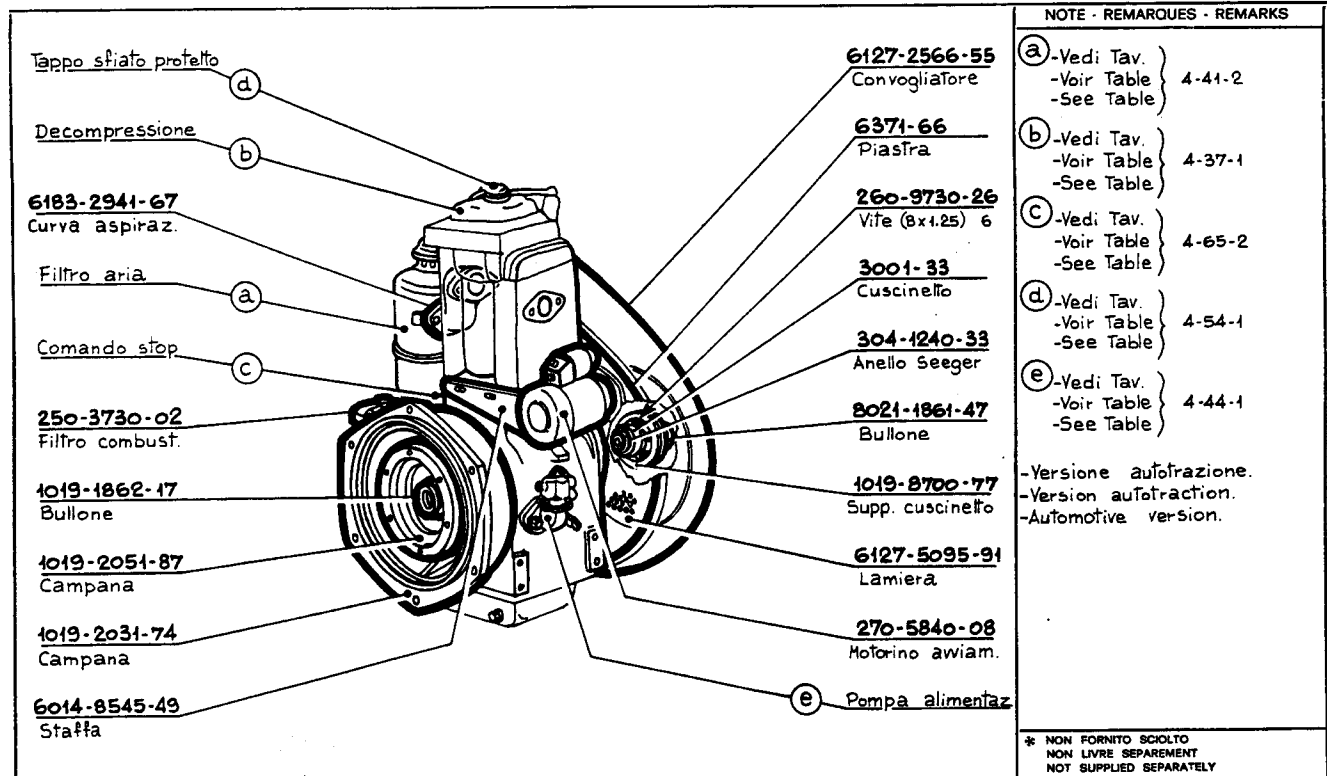

NOTE - REMARQUES - REMARKS

(a) -Vedi Tav. }
-Voir Table } 4-41-2
-See Table }

(b) -Vedi Tav. }
-Voir Table } 4-37-1
-See Table }

(c) -Vedi Tav. }
-Voir Table } 4-65-2
-See Table }

(d) -Vedi Tav. }
-Voir Table } 4-54-1
-See Table }

(e) -Vedi Tav. }
-Voir Table } 4-44-1
-See Table }

-Versione autofrazione.
-Version autofraction.
-Automotive version.

* NON FORNITO SCOLTO
NON LIVRE SEPAREMENT
NOT SUPPLIED SEPARATELY

COMPLESSIVO - GROUPE - ASSEMBLY		HAKO - TRATTORE TRACTEUR TRACTOR	TAVOLA TABLE	4	100	1
MOTORE O VERSIONE MOTEUR OU ADAPTATION ENGINE OR VERSION	(K. 20654) LDA 820		FOGLIO FEUILLE PAGE	1		2
			DATA DATE	2 - 73		



CATALOGO GENERALE RICAMBI

<p>270-4500-05 Guarnizione</p> <p>236-3240-37 Dado (40x1.5) 2</p> <p>30-7555-08 Rondella 2</p> <p>6800-65 Prigioniero (40x1.5)</p> <p>443-6800-10 Prigioniero (40x1.5)</p> <p>1019-3901-45 Flangia</p> <p>999-1780-31 Bullone (10x1.5) 2</p> <p>1-3240-18 Dado (8x1.25)</p> <p>47-1770-07 Bullone (8x1.25)</p> <p>1-7565-07 Rondella</p> <p>417-1770-03 Bullone (8x1.25) 6</p>	<p>308-4900-15 Bullone (14x1.5) 2</p> <p>1-4670-16 Guarnizione 4</p> <p>260-4900-01 Bullone (6x1)</p> <p>260-4670-01 Guarnizione</p> <p>6549-9374-01 Tubo filtro-pompa iniezione.</p> <p>6549-9570-83 Tubo spurgo.</p> <p>6549-9373-43 Tubo pompa alim.-filtro.</p> <p>270-3240-53 Dado (40x1.5) 2</p> <p>30-7555-08 Rondella 4</p> <p>270-3825-05 Flangia</p> <p>6549-9373-78 Tubo mand. comb.</p> <p>270-6745-01 Interruttore</p>	<p>NOTE - REMARQUES - REMARKS</p> <p>-Versione autotrazione. -Version autotraction. -Automotive version.</p> <p>* NON FORNITO SCOLTO NON LIVRE SEPARATEMENT NOT SUPPLIED SEPARATELY</p>													
<p>COMPLESSIVO - GROUPE - ASSEMBLY</p>		<p>TRATTORE HAKO - TRACTEUR TRACTOR</p>	<table border="1" style="border-collapse: collapse;"> <tr> <td>TAVOLA TABLE</td> <td>4</td> <td>100</td> <td>1</td> </tr> <tr> <td>FOGLIO FEUILLE PAGE</td> <td>2</td> <td></td> <td>2</td> </tr> <tr> <td>DATA DATE</td> <td colspan="3">2 - 73</td> </tr> </table>	TAVOLA TABLE	4	100	1	FOGLIO FEUILLE PAGE	2		2	DATA DATE	2 - 73		
TAVOLA TABLE	4	100	1												
FOGLIO FEUILLE PAGE	2		2												
DATA DATE	2 - 73														
<p>MOTORE O VERSIONE MOTEUR OU ADAPTATION ENGINE OR VERSION</p>	<p>(K. 20654) LDA 820</p>														

<p>Filtro aria</p> <p>Comando accelerat.</p> <p>Comando stop</p> <p>6016-2086-01 Campana</p> <p>6016-2085-99 Campana</p> <p>1080-2030-63 Campana</p> <p>6493-8545-43 Staffa</p>	<p>Decompressione</p> <p>6493-9542-08 Tubo scarico</p> <p>276-4500-79 Guarnizione</p> <p>Puleggia aviam.</p> <p>Avviam. elettrico</p> <p>Marmitta scarico</p> <p>Filtro olio</p> <p>6493-9180-48 Terminale</p>	<p>NOTE - REMARQUES - REMARKS</p> <p>(a) -Vedi Tav. } -Voir Table } 4-41-2 -See Table }</p> <p>(b) -Vedi Tav. } -Voir Table } 4-42-3 -See Table }</p> <p>(c) -Vedi Tav. } -Voir Table } 4-37-1 -See Table }</p> <p>(d) -Vedi Tav. } -Voir Table } 4-57-1 -See Table }</p> <p>(e) -Vedi Tav. } -Voir Table } 4-61-9 -See Table }</p> <p>(f) -Vedi Tav. } -Voir Table } 4-68-1 -See Table }</p> <p>(g) -Vedi Tav. } -Voir Table } 4-64-2 -See Table }</p> <p>(h) -Vedi Tav. } -Voir Table } 4-65-2 -See Table }</p> <p>-Versione autotrazione. -Version autotraction. -Automotive version.</p> <p>* NON FORNITO SCOLTO NON LIVRE SEPARATEMENT NOT SUPPLIED SEPARATELY</p>													
<p>COMPLESSIVO - GROUPE - ASSEMBLY</p>		<p>COMPRESSORE "1400 L." BERNARD - COMPRESSEUR "1400 L." "1400 L." COMPRESSOR</p>	<table border="1" style="border-collapse: collapse;"> <tr> <td>TAVOLA TABLE</td> <td>4</td> <td>100</td> <td>4</td> </tr> <tr> <td>FOGLIO FEUILLE PAGE</td> <td>1</td> <td></td> <td>2</td> </tr> <tr> <td>DATA DATE</td> <td colspan="3">2 - 73</td> </tr> </table>	TAVOLA TABLE	4	100	4	FOGLIO FEUILLE PAGE	1		2	DATA DATE	2 - 73		
TAVOLA TABLE	4	100	4												
FOGLIO FEUILLE PAGE	1		2												
DATA DATE	2 - 73														
<p>MOTORE O VERSIONE MOTEUR OU ADAPTATION ENGINE OR VERSION</p>	<p>LDA 820 (K. 40276)</p>														



CATALOGO GENERALE RICAMBI

11-3240-34
Dado (10x1.5) 2

30-7555-08
Rondella 2

202-7565-11
Rondella 7

406-1780-05
Bullone (10x1.5) 7

6398-6427-98
Piede aspiraz.

450-3240-36
Dado (10x1.5) 6

202-7565-11
Rondella 6

26-1780-07
Bullone (10x1.5) 6

1-7565-07
Rondella

3-3240-19
Dado (8x1.25) 2

1-7565-07
Rondella 2

1-1770-06
Bullone (8x1.25) 2

406-1780-05
Bullone (10x1.5) 2

6520-8635-45
Supporto 4

6398-6427-92
Piede scarico

6398-6427-93
Piede 4

105-7565-13
Rondella 8

9-3240-40
Dado (12x1.5) 8

1-1770-06
Bullone (8x1.25)

NOTE - REMARQUES - REMARKS
-Versione autofrazione.
-Version autofraction.
-Automotive version.

* NON FORNITO SCIOLTO
NON LIVRE SEPARMENT
NOT SUPPLIED SEPARATELY

COMPLESSIVO - GROUPE - ASSEMBLY		TAVOLA TABLE	4	100	4
MOTORE O VERSIONE MOTEUR OU ADAPTATION ENGINE OR VERSION	LDA 820 (K. 40276)	FOGLIO FEUILLE PAGE	2	2	
		DATA DATE	2 - 73		

**BERNARD - COMPRESSEUR "1400 L.,
"1400 L., COMPRESSOR**

Filtro aria

Comando accelerat. (a)

Comando stop (c)

(K. 9968.58)
Gruppo centrifugo

6005-1301-50
Anello compl.

6005-2085-80
Campana

8021-6646-02
Portina

270-3825-05
Flangia

30-7555-08
Rondella 2

270-3240-53
Dado (10x1.5) 2

Puleggia avviam. (f)

Filtro olio (e)

Piede 2 (b)

1-4670-16
Guarnizione

25-8965-05
Tappo (4x1.5)

NOTE - REMARQUES - REMARKS
(a) -Vedi Tav. }
-Voir Table } 4-41-1
-See Table }
(b) -Vedi Tav. }
-Voir Table } 4-24-1
-See Table }
(c) -Vedi Tav. }
-Voir Table } 4-64-3
-See Table }
(d) -Vedi Tav. }
-Voir Table } 4-65-2
-See Table }
(e) -Vedi Tav. }
-Voir Table } 4-57-1
-See Table }
(f) -Vedi Tav. }
-Voir Table } 4-68-1
-See Table }
-Versione industriale.
-Version industrielle.
-Industrial version.

* NON FORNITO SCIOLTO
NON LIVRE SEPARMENT
NOT SUPPLIED SEPARATELY

COMPLESSIVO - GROUPE - ASSEMBLY		TAVOLA TABLE	4	100	5
MOTORE O VERSIONE MOTEUR OU ADAPTATION ENGINE OR VERSION	LDA 96 (K. 4749)	FOGLIO FEUILLE PAGE			
		DATA DATE	2 - 73		

**MACO - COMPRESSEUR
COMPRESSOR**



CATALOGO GENERALE RICAMBI

NOTE - REMARQUES - REMARKS

- (a) - Vedi Tav. }
- Voir Table } 4-41-1
- See Table }
- (b) - Vedi Tav. }
- Voir Table } 4-24-1
- See Table }
- (c) - Vedi Tav. }
- Voir Table } 4-64-3
- See Table }
- (d) - Vedi Tav. }
- Voir Table } 4-65-2
- See Table }
- (e) - Vedi Tav. }
- Voir Table } 4-57-1
- See Table }
- (f) - Vedi Tav. }
- Voir Table } 4-68-1
- See Table }
- (g) - Vedi Tav. }
- Voir Table } 4-61-9
- See Table }
- (h) - Vedi Tav. }
- Voir Table } 4-67-8
- See Table }

-Versione industriale.
-Version industrielle.
-Industrial version.

* NON FORNITO SCIOLTO
NON LIVRE SEPARÉMENT
NOT SUPPLIED SEPARATELY

COMPLESSIVO - GROUPE - ASSEMBLY		TAVOLA TABLE	4	100	6
MOTORE O VERSIONE MOTEUR OU ADAPTATION ENGINE OR VERSION	LDA 100 (K. 4897)	COMPRESSORE "SUPER DAUPHIN," MACO - COMPRESSEUR "SUPER DAUPHIN," "SUPER DAUPHIN," COMPRESSOR	FOGLIO FEUILLE PAGE		
		DATA DATE	2	73	

NOTE - REMARQUES - REMARKS

- (a) - Vedi Tav. }
- Voir Table } 4-41-1
- See Table }
- (b) - Vedi Tav. }
- Voir Table } 4-61-7
- See Table }
- (c) - Vedi Tav. }
- Voir Table } 4-64-3
- See Table }
- (d) - Vedi Tav. }
- Voir Table } 4-65-2
- See Table }
- (e) - Vedi Tav. }
- Voir Table } 4-22-5
- See Table }
- (f) - Vedi Tav. }
- Voir Table } 4-67-4
- See Table }

-Versione industriale.
-Version industrielle.
-Industrial version.

* NON FORNITO SCIOLTO
NON LIVRE SEPARÉMENT
NOT SUPPLIED SEPARATELY

COMPLESSIVO - GROUPE - ASSEMBLY		TAVOLA TABLE	4	100	7
MOTORE O VERSIONE MOTEUR OU ADAPTATION ENGINE OR VERSION	LDA 96 (K. 4260)	PERFORATRICE MONTABERT - PERCEUSE DRILLING MACHINE	FOGLIO FEUILLE PAGE		
		DATA DATE	2	73	



CATALOGO GENERALE RICAMBI

6549-9570-65
Tubo spurgo

270-4775-39
Guarnizione 3

6549-9373-05
Tubo serbatoio -
pompa iniezione.

1-3240-18
Dado (8x1.25) 6

70-6780-46
Prigioniero (8x1.25) 6

8022-6960-52
Puleggia avviament.

NOTE - REMARQUES - REMARKS

(a) -Vedi Tav. }
-Voir Table } 4-41-1
-See Table }

(b) -Vedi Tav. }
-Voir Table } 4-61-7
-See Table }

(c) -Vedi Tav. }
-Voir Table } 4-64-3
-See Table }

(d) -Vedi Tav. }
-Voir Table } 4-65-2
-See Table }

(e) -Vedi Tav. }
-Voir Table } 4-22-5
-See Table }

(f) -Vedi Tav. }
-Voir Table } 4-67-4
-See Table }

(s) -Vedi Tav. }
-Voir Table } 4-57-1
-See Table }

-Versione industriale.
-Version industrielle.
-Industrial version.

* NON FORNITO SCOLTO
NON LIVRE SEPARATEMENT
NOT SUPPLIED SEPARATELY

COMPLESSIVO - GROUPE - ASSEMBLY			TAVOLA TABLE	4	100	8
MOTORE O VERSIONE MOTEUR OU ADAPTATION ENGINE OR VERSION	LDA 100 (K. 4869)	PERFORATRICE MONTABERT - PERCEUSE DRILLING MACHINE	FOGLIO FEUILLE PAGE			
			DATA DATE	2 - 73		

3052-3333-95
Decalcomania

443-6800-10
Prigioniero (40x1.5) 6

1080-2050-68
Campana

1080-1861-26
Bullone

202-1770-02
Bullone (8x1.25) 6

270-3825-05
Flangia

(K. 9975.25)
Predisposizione
pompa oleodinam.

270-4775-39
Guarnizione 2

1080-2030-63
Campana

NOTE - REMARQUES - REMARKS

(a) -Vedi Tav. }
-Voir Table } 4-41-4
-See Table }

(b) -Vedi Tav. }
-Voir Table } 4-61-7
-See Table }

(c) -Vedi Tav. }
-Voir Table } 4-65-2
-See Table }

(d) -Vedi Tav. }
-Voir Table } 4-67-4
-See Table }

-Versione autofrazione.
-Version autofraction.
-Automotive version.

* NON FORNITO SCOLTO
NON LIVRE SEPARATEMENT
NOT SUPPLIED SEPARATELY

COMPLESSIVO - GROUPE - ASSEMBLY			TAVOLA TABLE	4	100	9
MOTORE O VERSIONE MOTEUR OU ADAPTATION ENGINE OR VERSION	LDA 97 (K. 3449)	CARRELLO ELEVATORE OUDIN - CHARIOT ELEVATEUR LOADER	FOGLIO FEUILLE PAGE			
			DATA DATE	2 - 73		



CATALOGO GENERALE RICAMBI

NOTE - REMARQUES - REMARKS

- (a) -Vedi Tav. } 4-41-1
-Voir Table }
-See Table }
- (b) -Vedi Tav. } 4-61-7(LDA 97)
-Voir Table } 4-61-9(LDA 100)
-See Table }
- (c) -Vedi Tav. } 4-22-5
-Voir Table }
-See Table }

-Versione autotrazione.
-Version autotraction.
-Automotive version.

* NON FORNITO SCOLTO
NON LIVRE SEPAREMENT
NOT SUPPLIED SEPARATELY

COMPLESSIVO - GROUPE - ASSEMBLY		MOTOCOLTIVATORE	TAVOLA	4	100	12
MOTORE O VERSIONE	LDA 97-100	TOMO VINKOVIC -	FOGLIO			
MOTEUR OU ADAPTATION	(K. 20364-20363)	MOTOCULTEUR	FEUILLE			
ENGINE OR VERSION		MOTOR TILLER	PAGE			
			DATA	2 - 73		

NOTE - REMARQUES - REMARKS

- (a) -Vedi Tav. } 4-82-2
-Voir Table }
-See Table }
- (b) -Vedi Tav. } 4-37-1
-Voir Table }
-See Table }
- (c) -Vedi Tav. } 4-61-7
-Voir Table }
-See Table }

-Versione autotrazione.
-Version autotraction.
-Automotive version.

* NON FORNITO SCOLTO
NON LIVRE SEPAREMENT
NOT SUPPLIED SEPARATELY

COMPLESSIVO - GROUPE - ASSEMBLY		TRASPORTATORE AGRICOLA	TAVOLA	4	100	15
MOTORE O VERSIONE	LDA 97	AEBI - TRANSPORTER AGRICOLE	FOGLIO	1	2	
MOTEUR OU ADAPTATION	(K. 3596)	AGRICULTURAL TRANSPORTER	FEUILLE			
ENGINE OR VERSION			PAGE			
			DATA	2 - 73		



CATALOGO GENERALE RICAMBI

270-4500-05
Guarnizione 2

270-4775-39
Guarnizione

Comando stop (d)

1001-1760-33
Bullone (6x1)

1001-6000-29
Pastiglia

70-9730-35
Vite (8x1.25) 2

202-1770-02
Bullone (8x1.25) 6

1001-9371-96
Tubo rifiuto

1001-9371-97
Tubo serbatoio-filtro nafta.

260-6780-25
Prigioniero(8x1.25) 6

1-7565-07
Rondella 8

1-3240-18
Dado (8x1.25) 8

260-6780-27
Prigioniero (8x1.25) 2

NOTE - REMARQUES - REMARKS

(d) -Vedi Tav. }
-Voir Table } 4-65-2
-See Table }

-Versione autofrazione.
-Version autofraction.
-Automotive version.

* NON FORNITO SCOLTO
NON LIVRE SEPAREMENT
NOT SUPPLIED SEPARATELY

COMPLESSIVO - GROUPE - ASSEMBLY		TRASPORTATORE AGRICOLO AEBI - TRANSPORTER AGRICOLE AGRICULTURAL TRANSPORTER	TAVOLA TABLE	4	100	15
MOTORE O VERSIONE MOTEUR OU ADAPTATION ENGINE OR VERSION	LDA 97 (K. 3596)		FOGLIO FEUILLE PAGE	2	2	
			DATA DATE	2 - 73		

1001-3334-60
Decalcomania

1033-1400-34
Asta livello

(K. 9967. 81)
Dinamo

Filtro aria (a)

270-7865-08
Scatola regolatore

270-1860-74
Bullone

3835-05
Flangia

1001-2690-49
Coperchio

Equilibratore dinamico (b)

2300-12
Chiave

260-2350-28
Chiave

(K. 9967. 80)
Serbatoio combust.

(d) Serbatoio combust.

(c) Aviam. elettrico

280-7362-20
Regolatore

1001-2566-41
Convogliatore

279-1512-59
Basamento

260-6780-27
Prigioniero (8x1.25) 2

NOTE - REMARQUES - REMARKS

(a) -Vedi Tav. }
-Voir Table } 4-41-1
-See Table }

(b) -Vedi Tav. }
-Voir Table } 4-82-2
-See Table }

(c) -Vedi Tav. }
-Voir Table } 4-61-9
-See Table }

(d) -Vedi Tav. }
-Voir Table } 4-43-9
-See Table }

-Versione autofrazione.
-Version autofraction.
-Automotive version.

* NON FORNITO SCOLTO
NON LIVRE SEPAREMENT
NOT SUPPLIED SEPARATELY

COMPLESSIVO - GROUPE - ASSEMBLY		TRASPORTATORE AGRICOLO AEBI - TRANSPORTER AGRICOLE AGRICULTURAL TRANSPORTER	TAVOLA TABLE	4	100	16
MOTORE O VERSIONE MOTEUR OU ADAPTATION ENGINE OR VERSION	LDA 100 (K. 3488)		FOGLIO FEUILLE PAGE	1	2	
			DATA DATE	2 - 73		



CATALOGO GENERALE RICAMBI

NOTE - REMARQUES - REMARKS

(e) -Vedi Tav. }
 -Voir Table } 4-65-2
 -See Table }
 -Versione autotrazione.
 -Version autotraction.
 -Automotive version.

COMPLESSIVO - GROUPE - ASSEMBLY		TRASPORTATORE AGRICOLO AEBI - TRANSPORTER AGRICOLE AGRICULTURAL TRANSPORTER	TAVOLA TABLE	4	100	16
MOTORE O VERSIONE MOTEUR OU ADAPTATION ENGINE OR VERSION	LDA 100 (K. 3488)		FOGLIO FEUILLE PAGE	2		2
			DATA DATE	2		73

NOTE - REMARQUES - REMARKS

(a) -Vedi Tav. }
 -Voir Table } 4-41-1
 -See Table }
 (b) -Vedi Tav. }
 -Voir Table } 4-37-1
 -See Table }
 (c) -Vedi Tav. }
 -Voir Table } 4-66-1
 -See Table }
 (d) -Vedi Tav. }
 -Voir Table } 4-61-7
 -See Table }
 -Versione autotrazione.
 -Version autotraction.
 -Automotive version.

COMPLESSIVO - GROUPE - ASSEMBLY		TRASPORTATORE AGRICOLO RAPID - TRANSPORTER AGRICOLE AGRICULTURAL TRANSPORTER	TAVOLA TABLE	4	100	17
MOTORE O VERSIONE MOTEUR OU ADAPTATION ENGINE OR VERSION	LDA 97 (K. 3603)		FOGLIO FEUILLE PAGE			
			DATA DATE	2		73



CATALOGO GENERALE RICAMBI

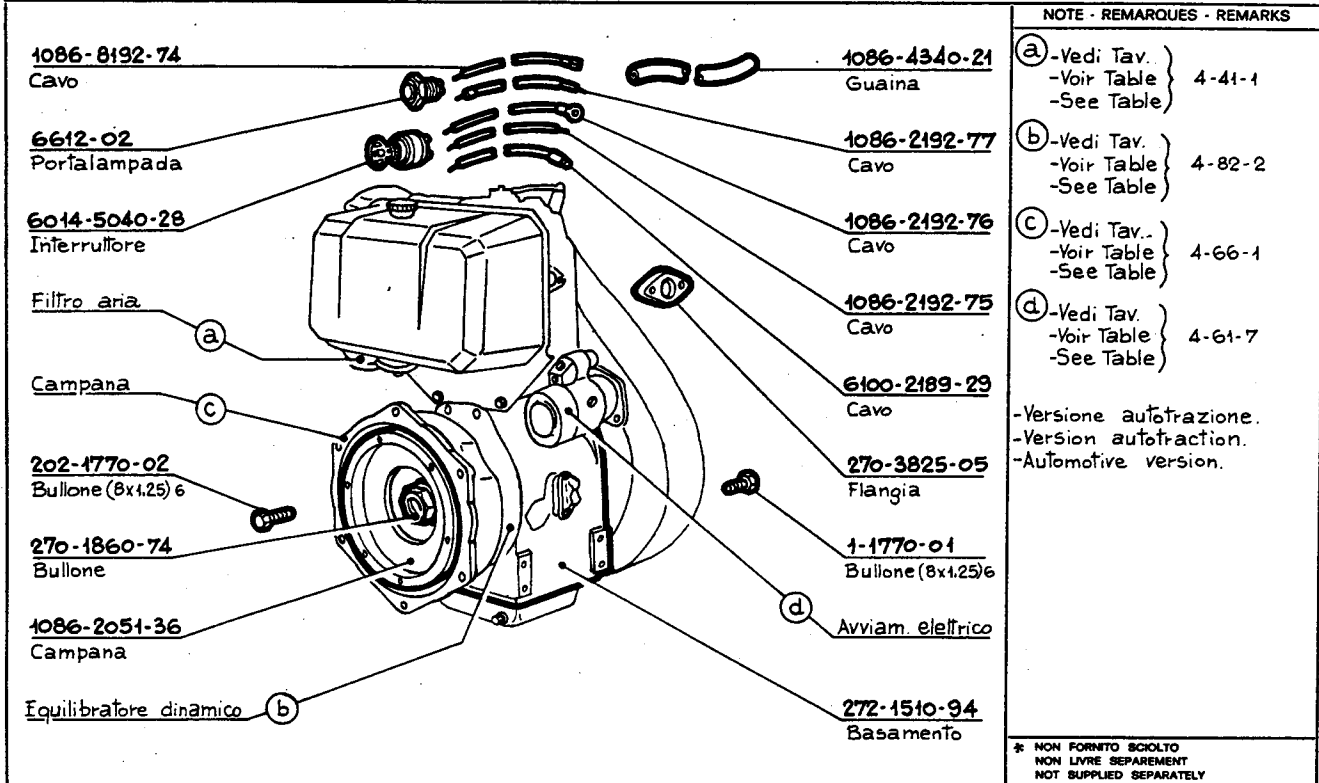

COMPLESSIVO - GROUPE - ASSEMBLY		SEMOVENTE AGRICOLO "1500, SCHILTER - TRANSPORTER AGRICOLE "1500, "1500, AGRIC. TRANSPORTER		TAVOLA TABLE	4	100	18
MOTORE O VERSIONE MOTEUR OU ADAPTATION ENGINE OR VERSION	LDA 97 (K. 3423)			FOGLIO FEUILLE PAGE			
				DATA DATE	2 - 73		

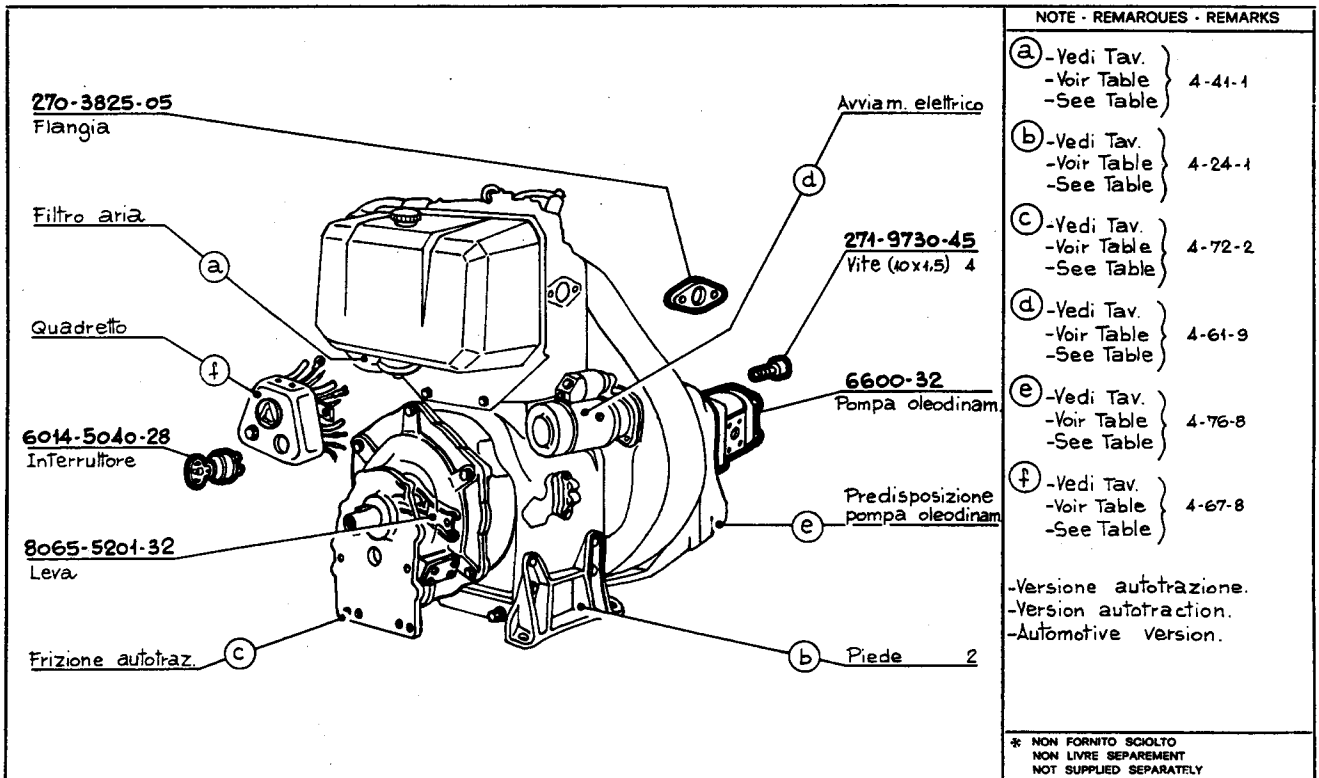

COMPLESSIVO - GROUPE - ASSEMBLY		WORMSER - DUMPER		TAVOLA TABLE	4	100	19
MOTORE O VERSIONE MOTEUR OU ADAPTATION ENGINE OR VERSION	LDA 100 (K. 3638)			FOGLIO FEUILLE PAGE			
				DATA DATE	2 - 73		



		NOTE - REMARQUES - REMARKS	
		<p>(a) -Vedi Tav. } -Voir Table } 4-41-4 -See Table }</p> <p>(b) -Vedi Tav. } -Voir Table } 4-42-1 -See Table }</p> <p>-Versione autotrazione. -Version autofraction. -Automotive version.</p>	
* NON FORNITO SCOLTO NON LIVRE SEPAREMENT NOT SUPPLIED SEPARATELY			
COMPLESSIVO - GROUPE - ASSEMBLY		TAVOLA TABLE 4 100 22	
MOTORE O VERSIONE MOTEUR OU ADAPTATION ENGINE OR VERSION	LDA 97 (K. 2915)	MOTOCOLTIVATORE "S 324,, BERTOLINI - MOTOCULTEUR "S 324,, "S 324,, MOTOR TILLER	
		FOGLIO FEUILLE PAGE	
		DATA DATE	2 - 73

		NOTE - REMARQUES - REMARKS	
		<p>(a) -Vedi Tav. } -Voir Table } 4-41-4 -See Table }</p> <p>(b) -Vedi Tav. } -Voir Table } 4-42-2 -See Table }</p> <p>(c) -Vedi Tav. } -Voir Table } 4-66-1 -See Table }</p> <p>-Versione autotrazione. -Version autofraction. -Automotive version.</p>	
* NON FORNITO SCOLTO NON LIVRE SEPAREMENT NOT SUPPLIED SEPARATELY			
COMPLESSIVO - GROUPE - ASSEMBLY		TAVOLA TABLE 4 100 23	
MOTORE O VERSIONE MOTEUR OU ADAPTATION ENGINE OR VERSION	LDA 100 (K. 20550)	MOTOCOLTIVATORE "320,, BERTOLINI - MOTOCULTEUR "320,, "320,, MOTOR TILLER	
		FOGLIO FEUILLE PAGE	
		DATA DATE	2 - 73



CATALOGO GENERALE RICAMBI

NOTE - REMARQUES - REMARKS

(a) -Vedi Tav. }
 -Voir Table } 4-41-2
 -See Table }

(b) -Vedi Tav. }
 -Voir Table } 4-42-4
 -See Table }

(c) -Vedi Tav. }
 -Voir Table } 4-37-1
 -See Table }

(d) -Vedi Tav. }
 -Voir Table } 4-61-9
 -See Table }

(e) -Vedi Tav. }
 -Voir Table } 4-66-1
 -See Table }

-Versione autotrazione.
 -Version autotracting.
 -Automotive version.

* NON FORNITO SCOLTO
 NON LIVRE SEPAREMENT
 NOT SUPPLIED SEPARATELY

COMPLESSIVO - GROUPE - ASSEMBLY		MOTOCOLTIVATORE "320," BERTOLINI - MOTOCULTEUR "320," "320," MOTOR TILLER	TAVOLA TABLE	4	100	24
MOTORE O VERSIONE MOTEUR OU ADAPTATION ENGINE OR VERSION	LDA 820 (K. 20934)		FOGLIO FEUILLE PAGE			
			DATA DATE	2 - 73		

NOTE - REMARQUES - REMARKS

(a) -Vedi Tav. }
 -Voir Table } 4-41-2
 -See Table }

(b) -Vedi Tav. }
 -Voir Table } 4-42-5
 -See Table }

(c) -Vedi Tav. }
 -Voir Table } 4-66-2
 -See Table }

(d) -Vedi Tav. }
 -Voir Table } 4-24-3
 -See Table }

-Versione industriale.
 -Version industrielle.
 -Industrial version.

* NON FORNITO SCOLTO
 NON LIVRE SEPAREMENT
 NOT SUPPLIED SEPARATELY

COMPLESSIVO - GROUPE - ASSEMBLY		GRUPPO ELETTROGENO CIRMET - GROUPE ELECTROGENE GENERATING SET	TAVOLA TABLE	4	100	27
MOTORE O VERSIONE MOTEUR OU ADAPTATION ENGINE OR VERSION	LDA 820 (K. 40368)		FOGLIO FEUILLE PAGE			
			DATA DATE	2 - 73		



CATALOGO GENERALE RICAMBI

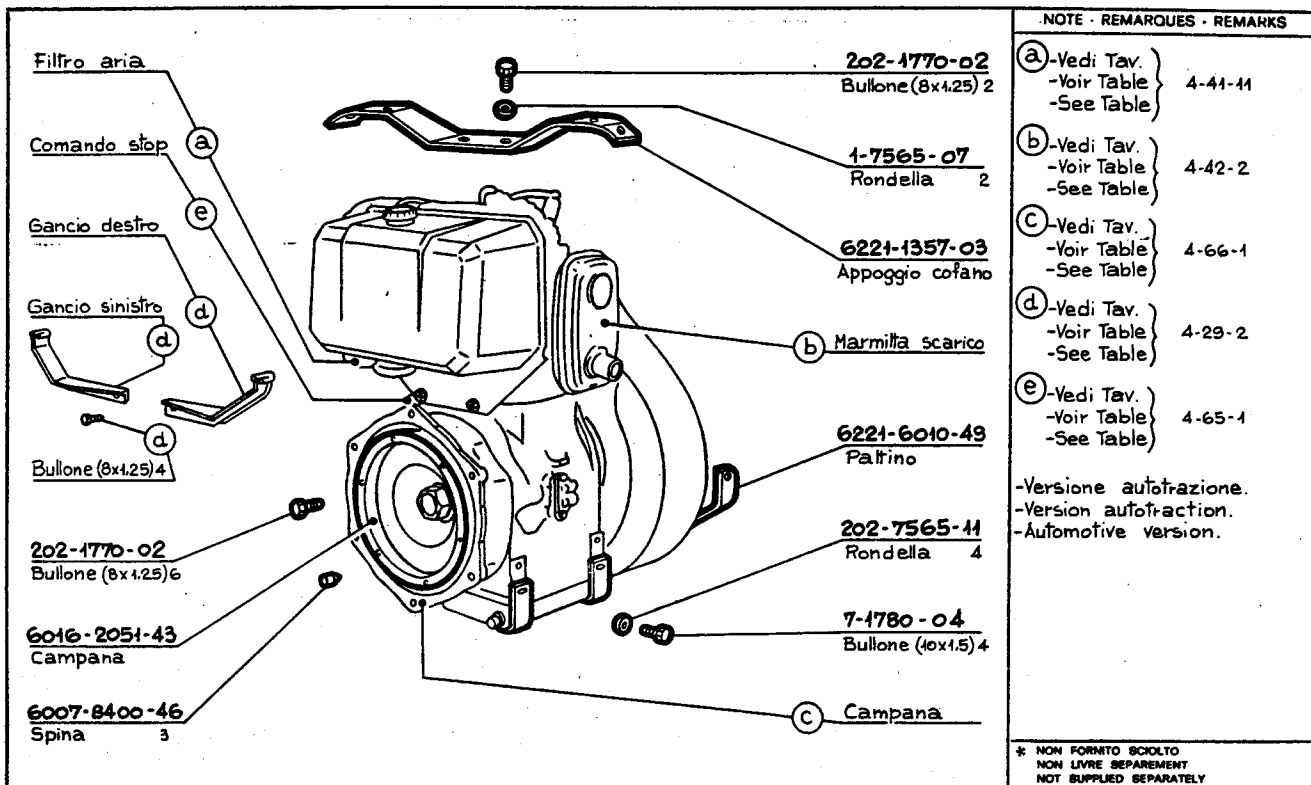

NOTE - REMARQUES - REMARKS

(a) - Vedi Tav. }
 - Voir Table } 4-41-11
 - See Table }

(b) - Vedi Tav. }
 - Voir Table } 4-42-2
 - See Table }

(c) - Vedi Tav. }
 - Voir Table } 4-66-1
 - See Table }

(d) - Vedi Tav. }
 - Voir Table } 4-29-2
 - See Table }

(e) - Vedi Tav. }
 - Voir Table } 4-65-1
 - See Table }

-Versione auto trazione.
 -Version autofraction.
 -Automotive version.

* NON FORNITO SCOLTO
 NON LIVRE SEPAREMENT
 NOT SUPPLIED SEPARATELY

COMPLESSIVO - GROUPE - ASSEMBLY		MOTOCOLTIVATORE "74,, FERRARI - MOTOCULTEUR "74,, "74,, MOTOR TILLER	TAVOLA TABLE	4	100	30
MOTORE O VERSIONE MOTEUR OU ADAPTATION ENGINE OR VERSION	LDA 100 (K.20978)		FOGLIO FEUILLE PAGE			
			DATA DATE	2 - 73		

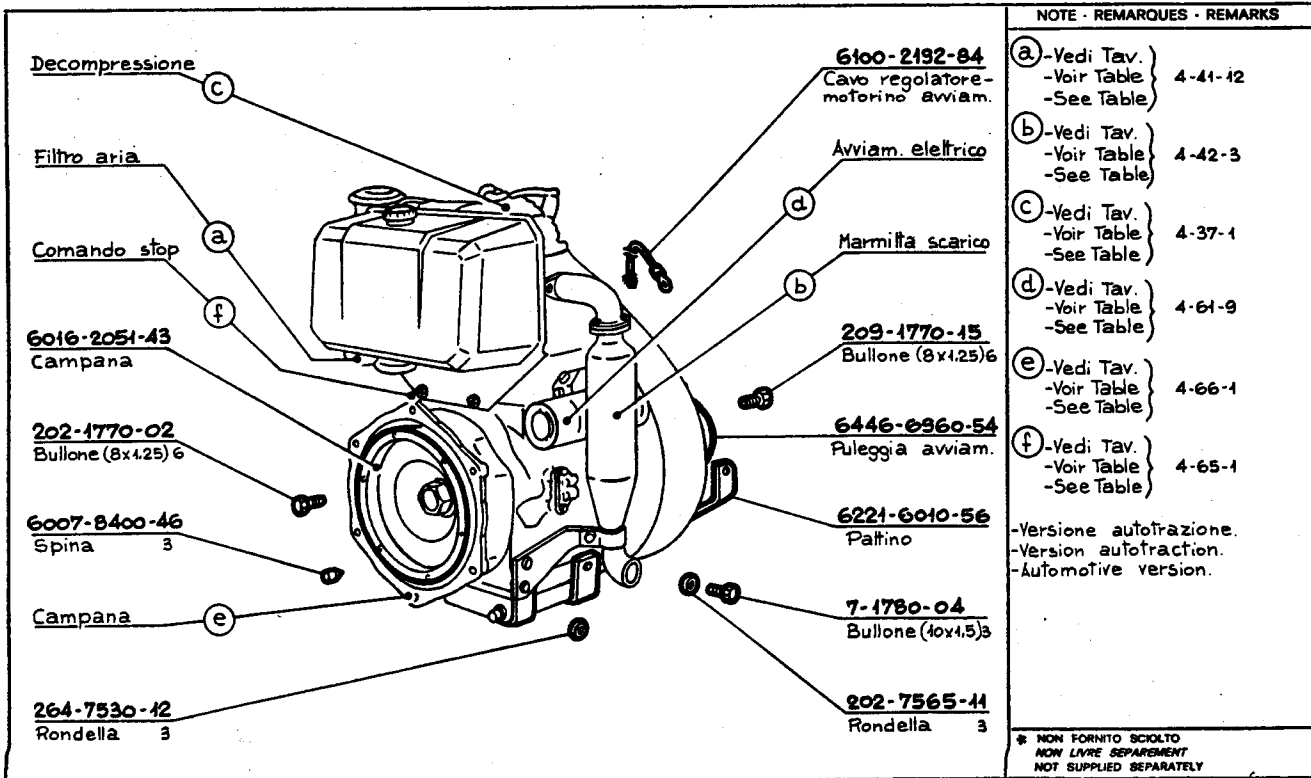

NOTE - REMARQUES - REMARKS

(a) - Vedi Tav. }
 - Voir Table } 4-41-12
 - See Table }

(b) - Vedi Tav. }
 - Voir Table } 4-42-3
 - See Table }

(c) - Vedi Tav. }
 - Voir Table } 4-37-1
 - See Table }

(d) - Vedi Tav. }
 - Voir Table } 4-61-9
 - See Table }

(e) - Vedi Tav. }
 - Voir Table } 4-66-1
 - See Table }

(f) - Vedi Tav. }
 - Voir Table } 4-65-1
 - See Table }

-Versione auto trazione.
 -Version autofraction.
 -Automotive version.

* NON FORNITO SCOLTO
 NON LIVRE SEPAREMENT
 NOT SUPPLIED SEPARATELY

COMPLESSIVO - GROUPE - ASSEMBLY		MOTOCOLTIVATORE "74,, FERRARI - MOTOCULTEUR "74,, "74,, MOTOR TILLER	TAVOLA TABLE	4	100	31
MOTORE O VERSIONE MOTEUR OU ADAPTATION ENGINE OR VERSION	LDA 820 (K.20925)		FOGLIO FEUILLE PAGE			
			DATA DATE	2 - 73		



CATALOGO GENERALE RICAMBI

NOTE - REMARQUES - REMARKS

(a) - Vedi Tav. }
 - Voir Table } 4-41-4
 - See Table }

(b) - Vedi Tav. }
 - Voir Table } 4-66-1
 - See Table }

(c) - Vedi Tav. }
 - Voir Table } 4-43-7
 - See Table }

-Versione autofrazione.
 -Version autotraction.
 -Automotive version.

* NON FORNITO SCOLTO
 NON LIVRE SEPARATEMENT
 NOT SUPPLIED SEPARATELY

COMPLESSIVO - GROUPE - ASSEMBLY		MOTOCOLTIVATORE "SUPER EX. E GM4," GOLDONI - MOTOCULTEUR "SUPER EX. E GM 4," "SUPER EX. E GM," MOTOR TILLER	TAVOLA TABLE	4	100	34
MOTORE O VERSIONE MOTEUR OU ADAPTATION ENGINE OR VERSION	LDA 97 (K. 2523)		FOGLIO FEUILLE PAGE			
			DATA DATE	2 - 73		

NOTE - REMARQUES - REMARKS

(a) - Vedi Tav. }
 - Voir Table } 4-41-4
 - See Table }

(b) - Vedi Tav. }
 - Voir Table } 4-42-4
 - See Table }

(c) - Vedi Tav. }
 - Voir Table } 4-66-1
 - See Table }

(d) - Vedi Tav. }
 - Voir Table } 4-43-7
 - See Table }

-Versione autofrazione.
 -Version autotraction.
 -Automotive version.

* NON FORNITO SCOLTO
 NON LIVRE SEPARATEMENT
 NOT SUPPLIED SEPARATELY

COMPLESSIVO - GROUPE - ASSEMBLY		MOTOCOLTIVATORE "518," GOLDONI - MOTOCULTEUR "518," "518," MOTOR TILLER	TAVOLA TABLE	4	100	35
MOTORE O VERSIONE MOTEUR OU ADAPTATION ENGINE OR VERSION	LDA 100 (K. 2786)		FOGLIO FEUILLE PAGE			
			DATA DATE	2 - 73		



CATALOGO GENERALE RICAMBI

Decompressione (d)

Serbatoio combust. (c)

Filtro aria (a)

6103-3701-74
Filtro aria

Comando stop (f)

Campana (e)

Campana (e)

(K.9980-70)
Avviam. elettrico

Marmitta scarico (b)

6446-6960-54
Puleggia avviam.

209-1770-15
Bullone(8x1.25) 6

264-8965-03
Tappo (42x1.5)

260-1900-46
Bullone

200-4670-03
Guarnizione

NOTE - REMARQUES - REMARKS

(a) -Vedi Tav. }
-Voir Table } 4-41-16
-See Table }

(b) -Vedi Tav. }
-Voir Table } 4-42-4
-See Table }

(c) -Vedi Tav... }
-Voir Table } 4-43-7
-See Table }

(d) -Vedi Tav. }
-Voir Table } 4-37-1
-See Table }

(e) -Vedi Tav. }
-Voir Table } 4-66-1
-See Table }

(f) -Vedi Tav. }
-Voir Table } 4-65-1
-See Table }

-Versione autofrazione.
-Version autofraction.
-Automotive version.

* NON FORNITO SCIOLTO
NON LIVRE SEPARMENT
NOT SUPPLIED SEPARATELY

COMPLESSIVO - GROUPE - ASSEMBLY		TRATTORE "UNIVERSAL 221," GOLDONI - TRACTEUR "UNIVERSAL 221," "UNIVERSAL 221," TRACTOR	TAVOLA TABLE	4	100/36
MOTORE O VERSIONE MOTEUR OU ADAPTATION ENGINE OR VERSION	LDA 820 (K.20677)		FOGLIO FEUILLE PAGE		
			DATA DATE	2	73

Serbatoio combust. (d)

6496-8101-71
Serbatoio combust.

Filtro aria (a)

Campana (c)

Campana (c)

6516-5450-09
Manometro olio

200-1900-02
Bullone (8x1)

Marmitta scarico (b)

Curva scarico (b)

Guarnizione (b)

Prigioniero(40x1.5) 2 (b)

Rondella 2 (b)

Dado (40x1.5) 2 (b)

6551-9475-36
Tubo

200-4670-03
Guarnizione

NOTE - REMARQUES - REMARKS

(a) -Vedi Tav. }
-Voir Table } 4-41-11
-See Table }

(b) -Vedi Tav. }
-Voir Table } 4-42-7
-See Table }

(c) -Vedi Tav. }
-Voir Table } 4-66-1
-See Table }

(d) -Vedi Tav. }
-Voir Table } 4-43-7
-See Table }

-Versione autofrazione.
-Version autofraction.
-Automotive version.

* NON FORNITO SCIOLTO
NON LIVRE SEPARMENT
NOT SUPPLIED SEPARATELY

COMPLESSIVO - GROUPE - ASSEMBLY		TRATTORE E MOTOCOLTIVATORE NIBBI - TRACTEUR ET MOTOCULTEUR TRACTOR AND MOTOR TILLER	TAVOLA TABLE	4	100/39
MOTORE O VERSIONE MOTEUR OU ADAPTATION ENGINE OR VERSION	LDA 97 (K.20073)		FOGLIO FEUILLE PAGE		
			DATA DATE	2	73



CATALOGO GENERALE RICAMBI

Regolatore (f)

70-9730-24
Vite (8x1.25) 2 (f)

1028-3206-21
Dado 2

Filtro aria (a)

Comando stop (e)

1028-2051-84
Campana

6016-2031-51
Campana

6493-8545-46
Staffa

Decompressione (c)

6493-2941-64
Curva scarico

6127-2567-14
Convogliatore

Marmitta scarico (b)

202-4770-02
Bullone (8x1.25)4

1-7565-07
Rondella 4

6127-6371-75
Piastra

Aviam. elettrico (d)

NOTE - REMARQUES - REMARKS

(a) -Vedi Tav. }
-Voir Table } 4-41-10
-See Table }

(b) -Vedi Tav. }
-Voir Table } 4-42-4
-See Table }

(c) -Vedi Tav. }
-Voir Table } 4-37-1
-See Table }

(d) -Vedi Tav. }
-Voir Table } 4-61-10
-See Table }

-Motorino avviam. di fornitura Pasquali.
-Démarreur livré par Pasquali.
-Starter supplied by Pasquali.

(e) -Vedi Tav. }
-Voir Table } 4-65-1
-See Table }

(f) -Vedi Tav. }
-Voir Table } 4-61-10
-See Table }

-Versione autotrazione.
-Version autotracting.
-Automotive version.

* NON FORNITO SCIOLTO
NON LIVRE SEPARÉMENT
NOT SUPPLIED SEPARATELY

COMPLESSIVO - GROUPE - ASSEMBLY		MOTOCOLTIVATORE "955, PASQUALI - MOTOCULTEUR "955, "955, MOTOR TILLER	TAVOLA TABLE	4	100	44
MOTORE O VERSIONE MOTEUR OU ADAPTATION ENGINE OR VERSION	LDA 820 (K.20585)		FOGLIO FEUILLE PAGE			
			DATA DATE		2	73

270-4260-03
Golfare

Filtro aria (a)

Campana (c)

Campana (c)

Marmitta scarico (b)

209-4770-15
Bullone (8x1.25)6

6446-6960-54
Puleggia avviam.

NOTE - REMARQUES - REMARKS

(a) -Vedi Tav. }
-Voir Table } 4-41-4
-See Table }

(b) -Vedi Tav. }
-Voir Table } 4-42-1
-See Table }

(c) -Vedi Tav. }
-Voir Table } 4-66-1
-See Table }

-Versione autotrazione.
-Version autotracting.
-Automotive version.

* NON FORNITO SCIOLTO
NON LIVRE SEPARÉMENT
NOT SUPPLIED SEPARATELY

COMPLESSIVO - GROUPE - ASSEMBLY		MOTOCOLTIVATORE "L17, E "L17 F 20 D, P-G-S - MOTOCULTEUR "L17, ET "L17 F 20 D, "L17, AND "L17 F 20 D, MOTOR TILLER	TAVOLA TABLE	4	100	47
MOTORE O VERSIONE MOTEUR OU ADAPTATION ENGINE OR VERSION	LDA 97-100 (K.2592 - 2796)		FOGLIO FEUILLE PAGE			
			DATA DATE		2	73



CATALOGO GENERALE RICAMBI

NOTE - REMARQUES - REMARKS

- (a) - Vedi Tav. }
- Voir Table } 4-41-5
- See Table }
- (b) - Vedi Tav. }
- Voir Table } 4-42-4
- See Table }
- (c) - Vedi Tav. }
- Voir Table } 4-37-1
- See Table }
- (d) - Vedi Tav. }
- Voir Table } 4-61-9
- See Table }
- (e) - Vedi Tav. }
- Voir Table } 4-66-1
- See Table }
- (f) - Vedi Tav. }
- Voir Table } 4-65-2
- See Table }
- (g) - Vedi Tav. }
- Voir Table } 4-76-10
- See Table }

-Versione autotrazione.
-Version autotraction.
-Automotive version.

* NON FORNITO SCIOLTO
NON LIVRE SEPAREMENT
NOT SUPPLIED SEPARATELY

COMPLESSIVO - GROUPE - ASSEMBLY		TRATTORE "20-10L., P.G.S - TRACTEUR "20-10L., "20-10L., TRACTOR	TAVOLA TABLE	4	100	48
MOTORE O VERSIONE MOTEUR OU ADAPTATION ENGINE OR VERSION	LDA 820 (K. 20669)		FOGLIO FEUILLE PAGE			
			DATA DATE	2 - 73		

NOTE - REMARQUES - REMARKS

- (a) - Vedi Tav. }
- Voir Table } 4-41-4
- See Table }
- (b) - Vedi Tav. }
- Voir Table } 4-42-12
- See Table }
- (c) - Vedi Tav. }
- Voir Table } 4-66-1
- See Table }
- (d) - Vedi Tav. }
- Voir Table } 4-76-10
- See Table }
- (e) - Vedi Tav. }
- Voir Table } 4-65-2
- See Table }
- (f) - Vedi Tav. }
- Voir Table } 4-61-7
- See Table }

-Versione autotrazione.
-Version autotraction.
-Automotive version.

* NON FORNITO SCIOLTO
NON LIVRE SEPAREMENT
NOT SUPPLIED SEPARATELY

COMPLESSIVO - GROUPE - ASSEMBLY		PICCINI - DUMPER "800/16., "800/16., DUMPER	TAVOLA TABLE	4	100	51
MOTORE O VERSIONE MOTEUR OU ADAPTATION ENGINE OR VERSION	LDA 97 (K. 3347)		FOGLIO FEUILLE PAGE			
			DATA DATE	2 - 73		